

université  
de BORDEAUX



# SHORT TERM MECHANICAL CIRCULATORY SUPPORT: EXTRACORPOREAL LIFE SUPPORT



ANESTHÉSIE-RÉANIMATION  
CARDIOVASCULAIRE

*Prof. Alexandre OUATTARA*

*Département of Cardiovascular Anaesthesia and Critical Care*

*INSERM, UMR 1034 Biology of cardiovascular diseases*

*Haut-Lévêque university hospital, 33600 Pessac, FRANCE*



Lien d'intérêt à déclarer...

## Fresenius Medical Care (Synchronized Cardiac support, iCOR)

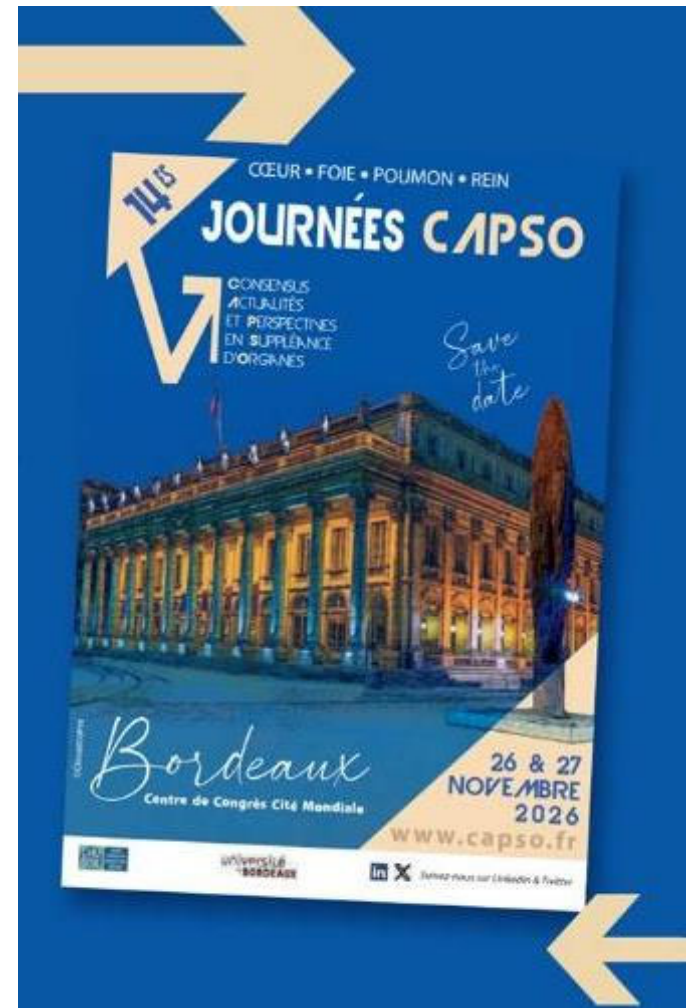
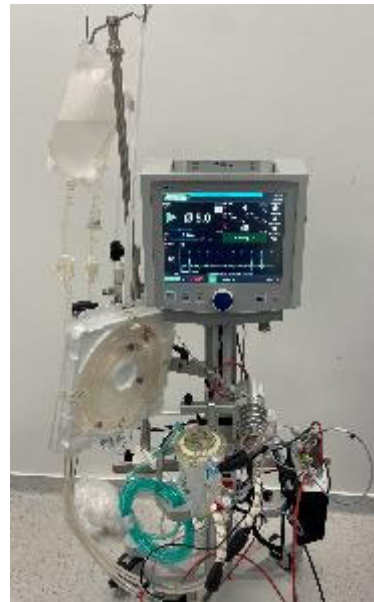

## ExtraCorporeal Membrane Oxygenation (ECMO)

Hill JD et al. *N Engl J Med* 1972; 286:629-34  
Zapol WM et al. *JAMA* 1979;242:2193-6

### Respiratory supply

Mostly veno-arterial  
Experience limited and delayed use  
Bleeding  
NO concomitant protective ventilatory strategies

## ExtraCorporeal CO<sub>2</sub> Removal (ECCO<sub>2</sub>R)

Gattinoni L et al. *JAMA* 1986; 256:881-6

### Respiratory supply

Veno-venous circuit with oxygenation by diffusion  
CO<sub>2</sub> extraction by membrane  
Epuration CO<sub>2</sub> par membrane

## Extracorporeal Lung Assist (ECLA)

Reng M et al. *Lancet* 2000; 356:219-220

### Respiratory supply

Pump is not required  
Arterio-venous shunt between femoral artery and vein

## ExtraCorporeal Life Support (ECLS)

Global term to define a respiratory and circulatory supply device  
Improve tissular perfusion (circulatory and/or respiratory supply)

## Extracorporeal Cardiopulmonary Resuscitation (ECCPR)

Respiratory and circulatory supply for CPR



The first successful extracorporeal life support patient treated by J. Donald Hill using Bramson oxygenator (Santa Barbara 1971)

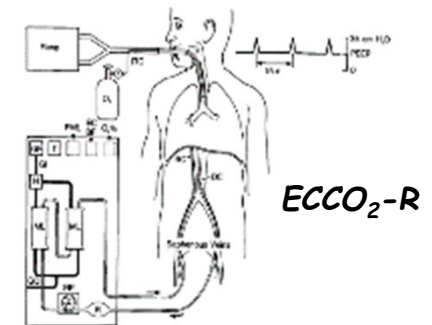

ECCO<sub>2</sub>-R

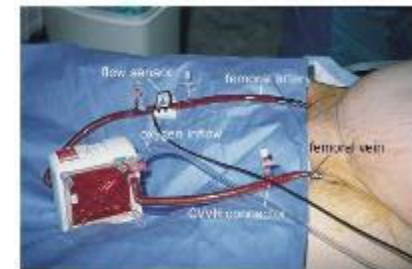

ECLA

- Therapeutics with high technology
- Circulatory and/or respiratory supply
- Derivated from Cardiopulmonary bypass of cardiac surgery
- Technology progress
  - Hemo-compatibility (coating),
  - Miniaturization,
  - Membrane of diffusion...
- Intensive care unit, emergency department and now for pre-hospital care...



John and Marry Gibbon (1953)

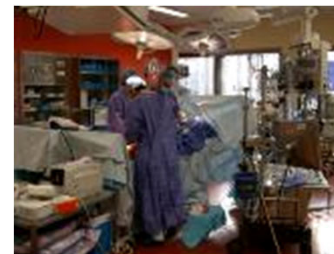

*Edmunds LH Jr N Engl J Med 2004; 351:1603-6*

*Stoney WS Circulation 2009; 119:2844-53*



Pediatric ECLS



Mobile unit



After cardiotomy



Out-hospital cardiac arrest  
« Louvre Museum »

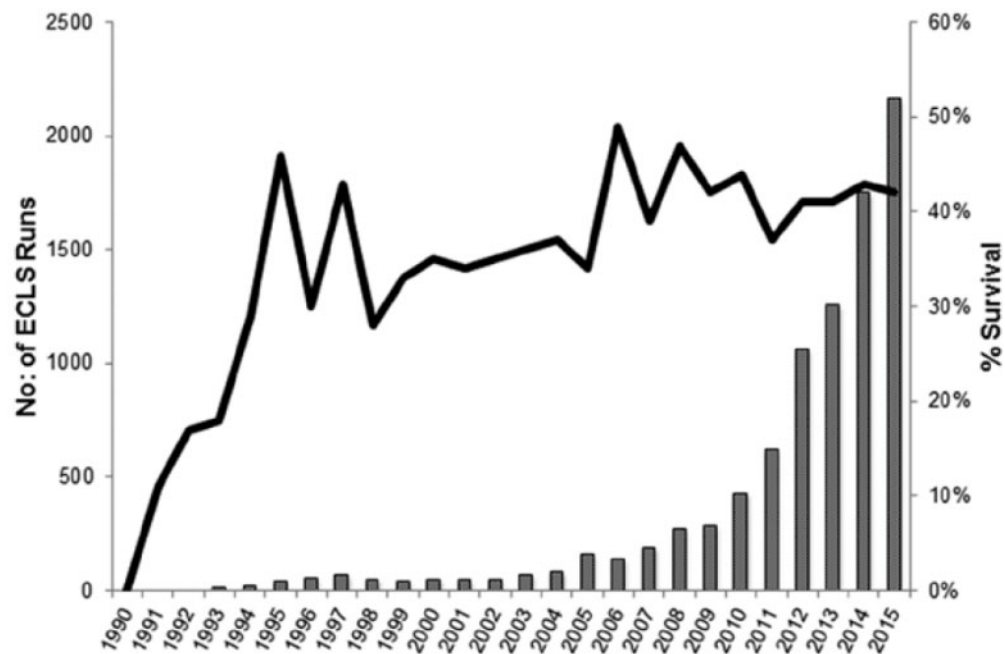

Thiagarajan RR et al. ASAIO Journal 2017;63:60-7

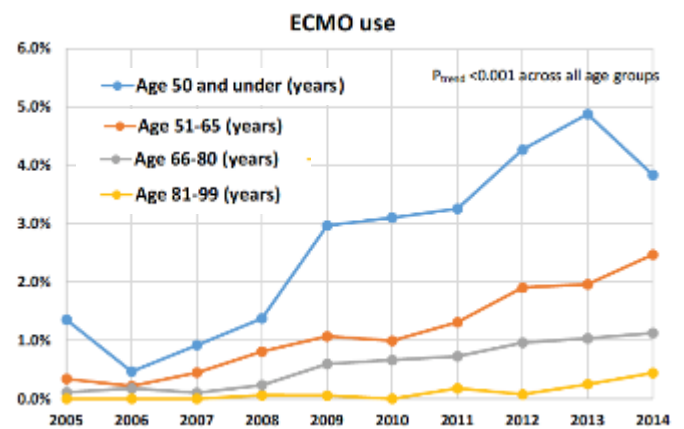
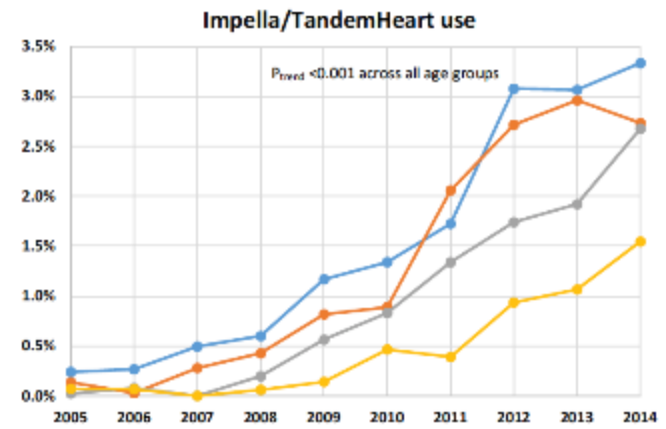

Shah M et al. Clin Res Cardiol 2018;107:287-303

# BRIDGE TO...

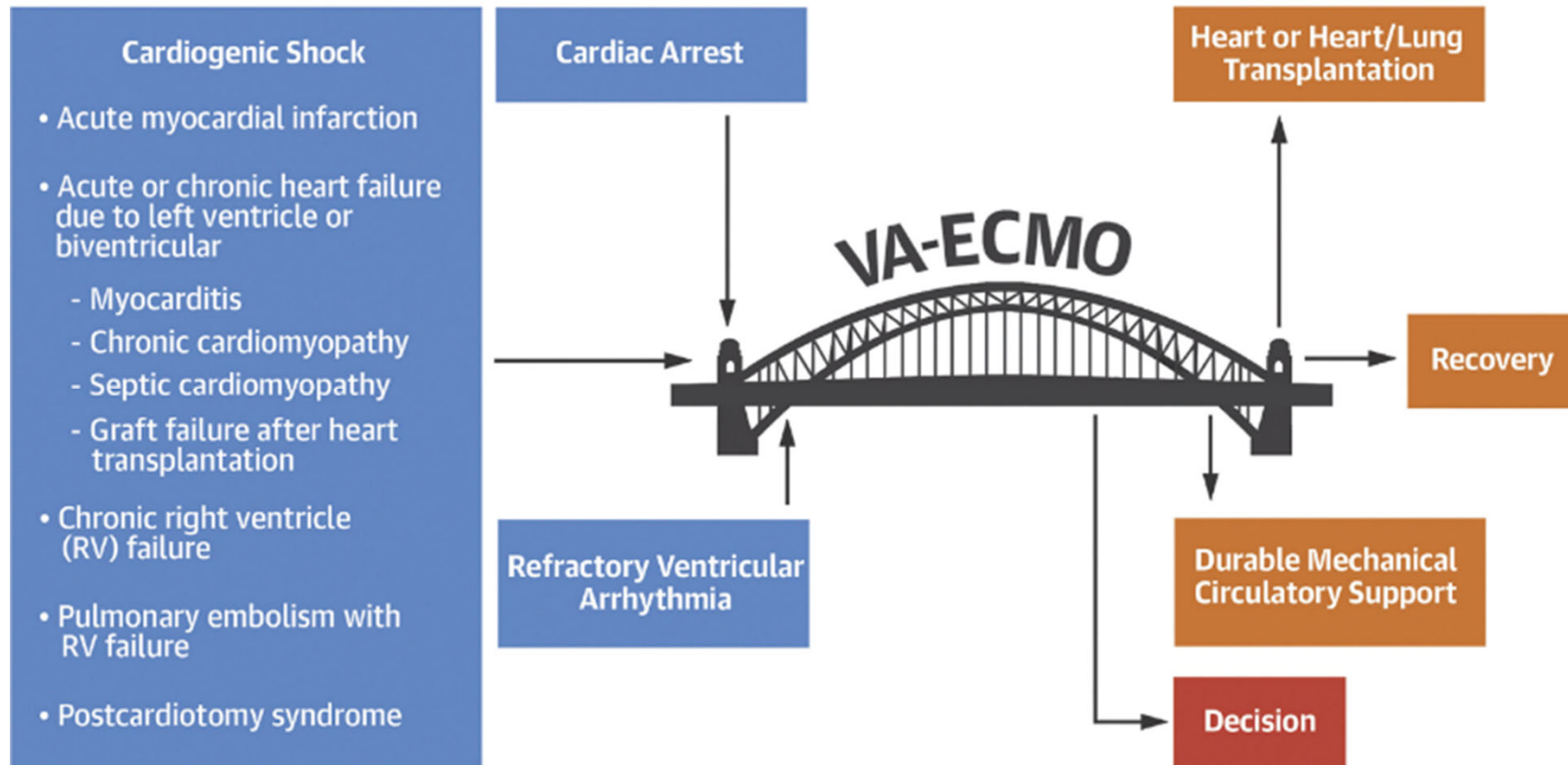

# Outcomes of Short Term Mechanical Circulatory Support (STMCS)



## BRIDGE TO...

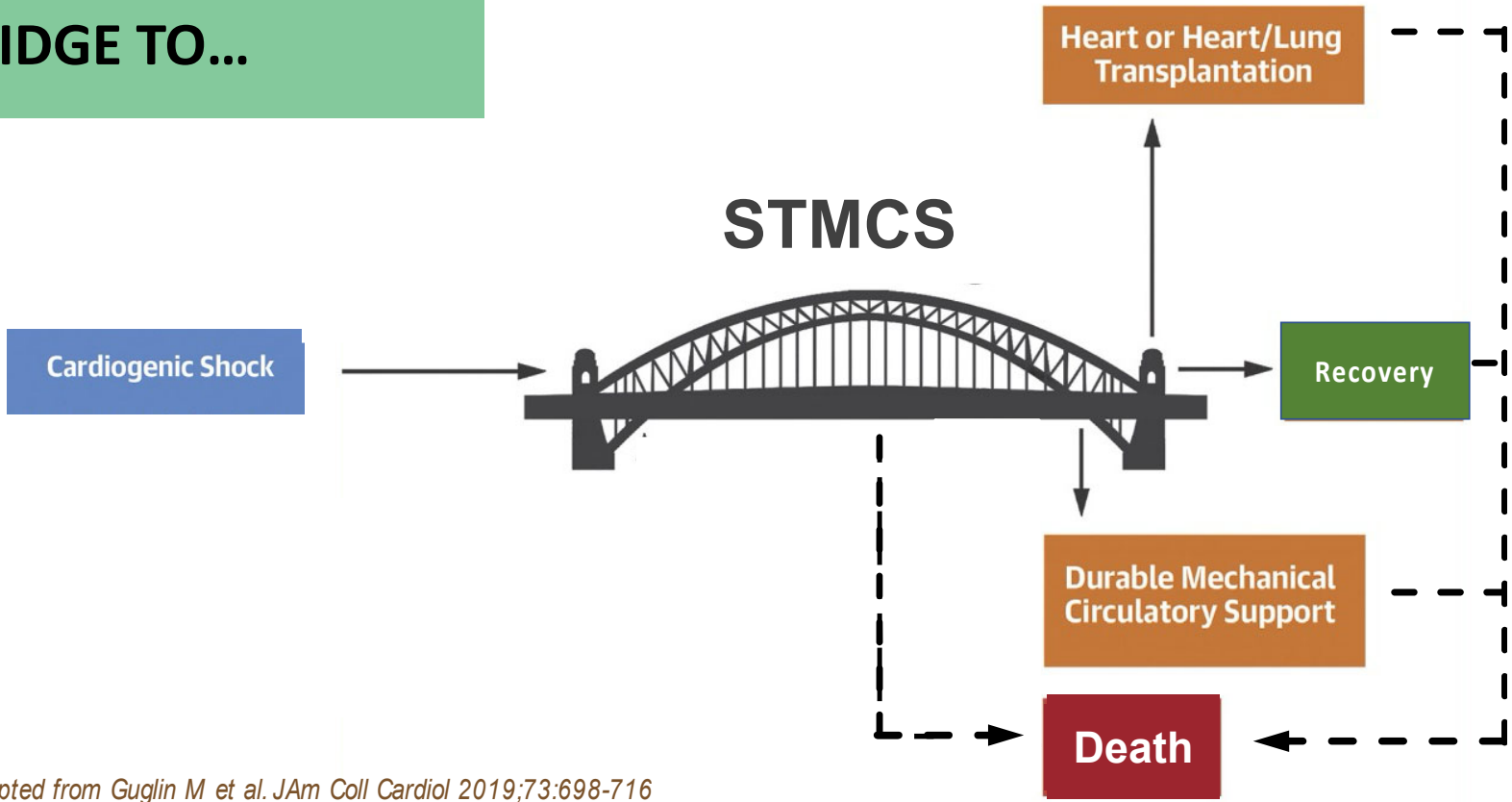

Adapted from Guglin M et al. JAm Coll Cardiol 2019;73:698-716

# Short-term Mechanical Circulatory Support (STMCS) prior to Left Ventricular Assist Device (LVAD)

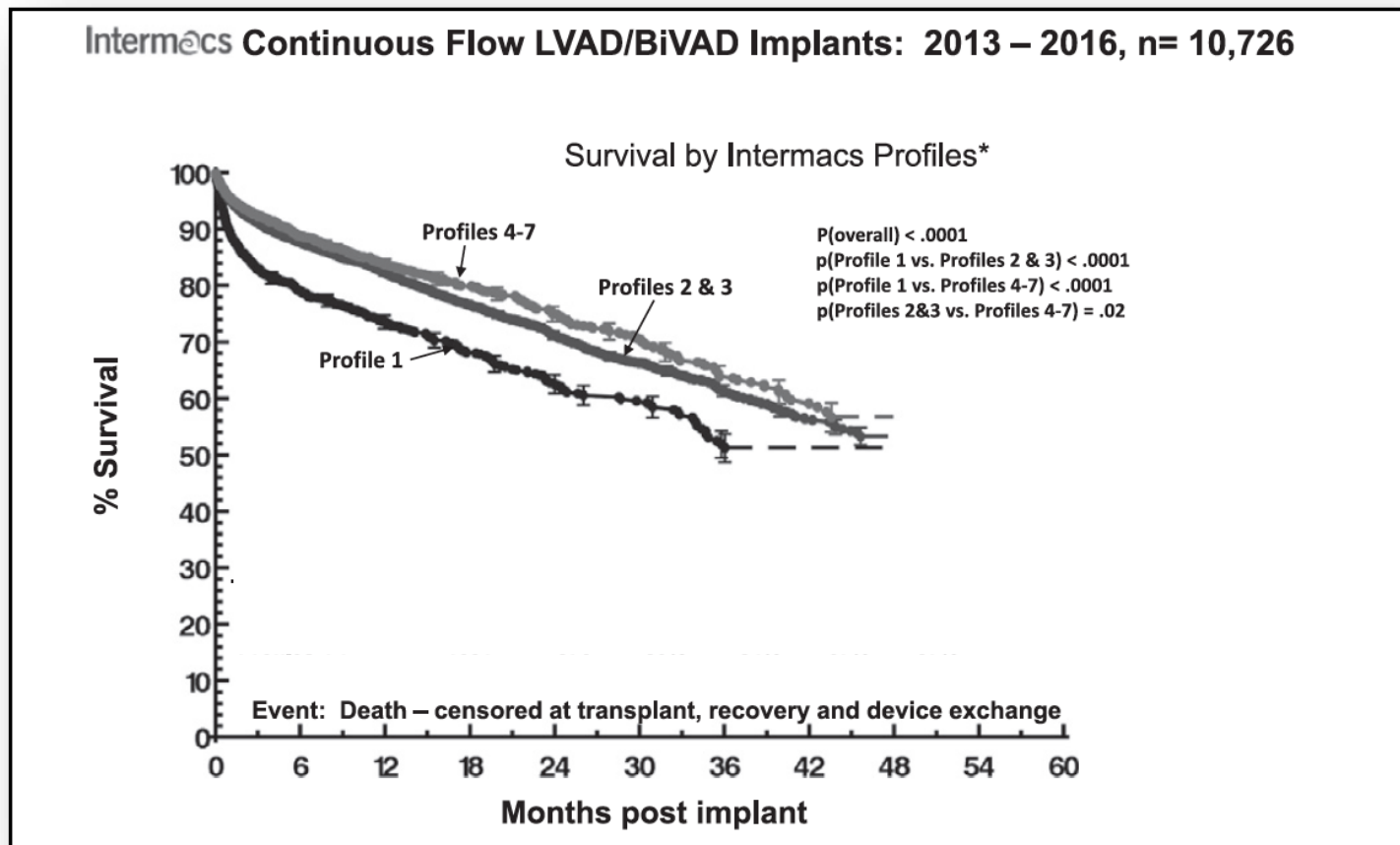

# SHORT TERM MECHANICAL CIRCULATORY SUPPORT (STMCS)

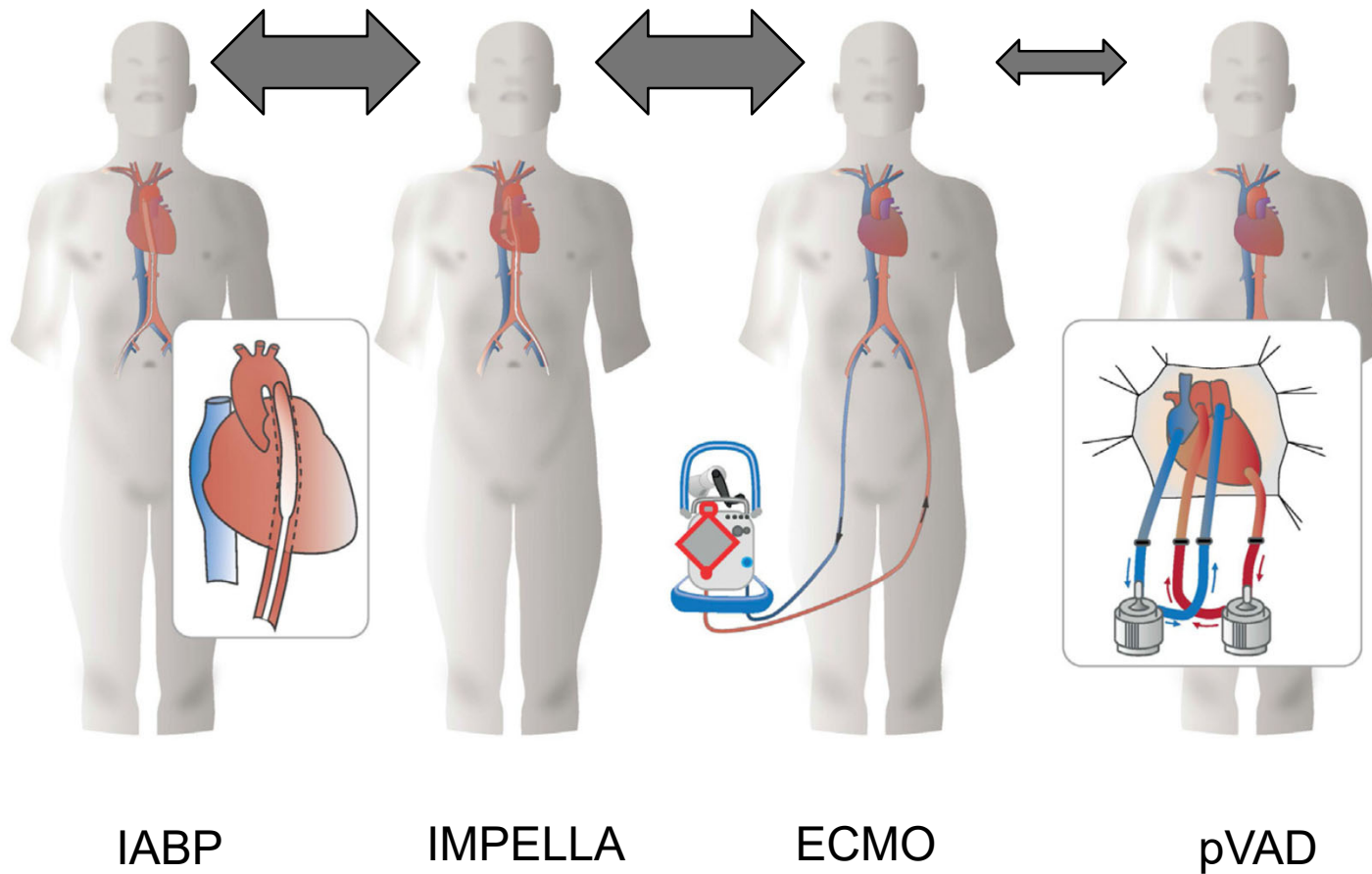

# ECLS DURATION AND OUTCOMES

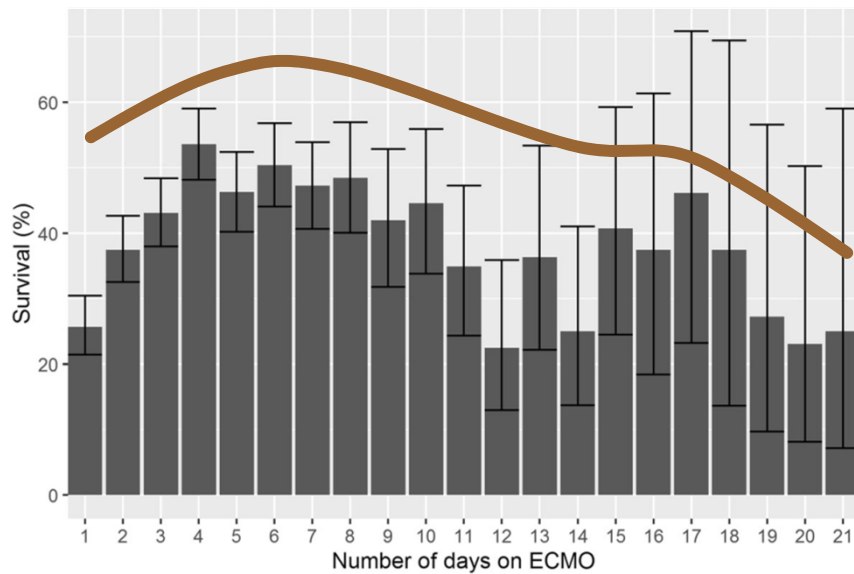

Smith M et al. Crit Care 2017; 21:45

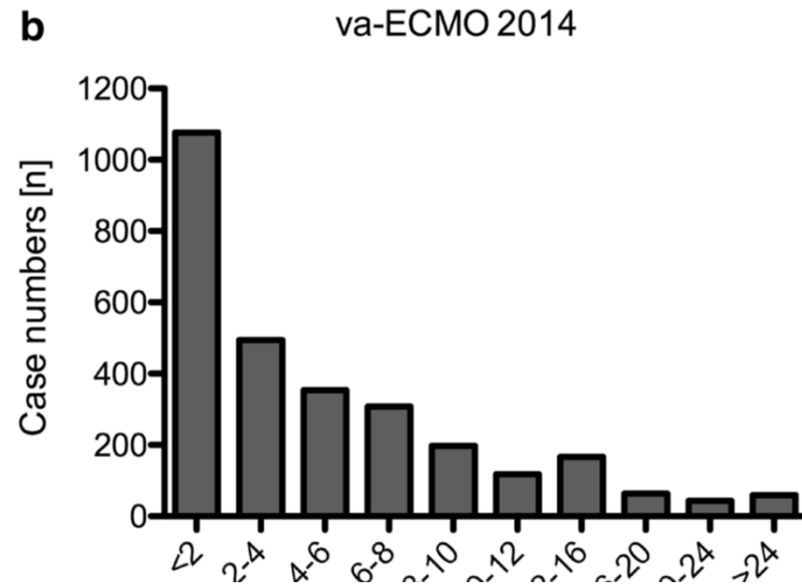

Karagiannidis C et al. Intensive Care Med 2016;42:889-96



**SOLUTION**

**PROBLEM**

	IABP (7.5-9 Fr)	IMPELLA 2.5 and CP	IMPELLA 5.0	ECLS
<b>Size of MCS</b>	7.5 to 8 Fr	Motor 12/14 Fr/Catheter 9 Fr	Motor 21 Fr/Catheter 9 Fr	A: 15-19 Fr/V: 23-29 Fr
<b>Very frequent (&gt; 10%)</b>	<ul style="list-style-type: none"> <li>• Thrombocytopenia</li> </ul>	<ul style="list-style-type: none"> <li>• Severe <i>access vascular bleeding</i>**</li> </ul>	<ul style="list-style-type: none"> <li>• Severe <i>access vascular bleeding</i> **</li> </ul>	<ul style="list-style-type: none"> <li>• Severe <i>access vascular bleeding</i>**</li> <li>• Site infection</li> </ul>
<b>Frequent (5-10%)</b>		<ul style="list-style-type: none"> <li>• Intravascular hemolysis</li> <li>• Site infection</li> </ul>	<ul style="list-style-type: none"> <li>• Limb ischemia*</li> <li>• Site infection</li> </ul>	<ul style="list-style-type: none"> <li>• Limb ischemia*</li> </ul>
<b>Non exceptional (1-5%)</b>	<ul style="list-style-type: none"> <li>• Device malfunction</li> <li>• Severe Limb ischemia*</li> <li>• Severe <i>access vascular bleeding</i> **</li> </ul>	<ul style="list-style-type: none"> <li>• Limb ischemia*</li> <li>• Device malfunction</li> <li>• Pump displacement</li> </ul>	<ul style="list-style-type: none"> <li>• Intravascular hemolysis</li> <li>• Device malfunction</li> <li>• Pump displacement</li> </ul>	<ul style="list-style-type: none"> <li>• Intravascular hemolysis</li> <li>• Pulmonary hemorrhage</li> </ul>
<b>Exceptional (&lt;1%)</b>	<ul style="list-style-type: none"> <li>• Retroperitoneal bleeding</li> <li>• Intravascular hemolysis</li> <li>• Aortic complication</li> <li>• Cerebral embolism</li> <li>• Paraplegia</li> <li>• Site infection</li> <li>• Mesenteric ischemia</li> <li>• Balloon leak</li> </ul>	<ul style="list-style-type: none"> <li>• Retroperitoneal bleeding</li> <li>• Functional mitral stenosis</li> <li>• Mitral regurgitation (chordal rupture)</li> <li>• Left ventricular wall perforation</li> <li>• Intra ventricular thrombosis</li> </ul>	<ul style="list-style-type: none"> <li>• Functional mitral stenosis</li> <li>• Mitral regurgitation (chordal rupture)</li> <li>• Aortic regurgitation</li> <li>• Left ventricular wall perforation</li> <li>• Intra ventricular thrombosis</li> </ul>	<ul style="list-style-type: none"> <li>• Aortic complication</li> <li>• Device malfunction</li> </ul>

## ECLS for cardiac indications

Diagnosis	No. Runs, N	Average ECLS Duration (hour)	Survival, N (%)
Adult (>16 years)			
Shock*	2,083	144	882 (42)
Cardiomyopathy	704	162	358 (51)
Myocarditis	227	188	143 (65)
Congenital defect	420	129	156 (37)

**~ 6 to 8 days**      **~ 50%**

## New graft allocation rules for heart transplantation *in France* (from January 2108)

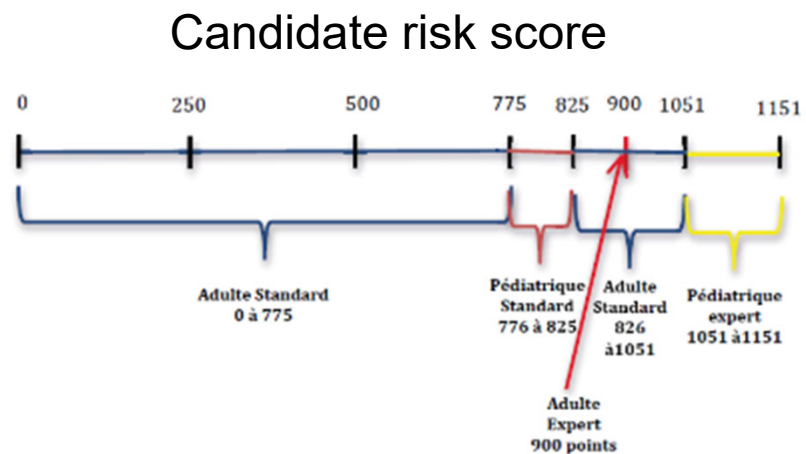

Since April 2019, the score decreases from 100% to 0% in candidates on VA-ECMO from 12 to 16 days of support duration.

## WHEN ? “NEITHER TOO EARLY NOR TO LATE”

SCAI: Society for Cardiovascular Angiography and Interventions (SCAI)

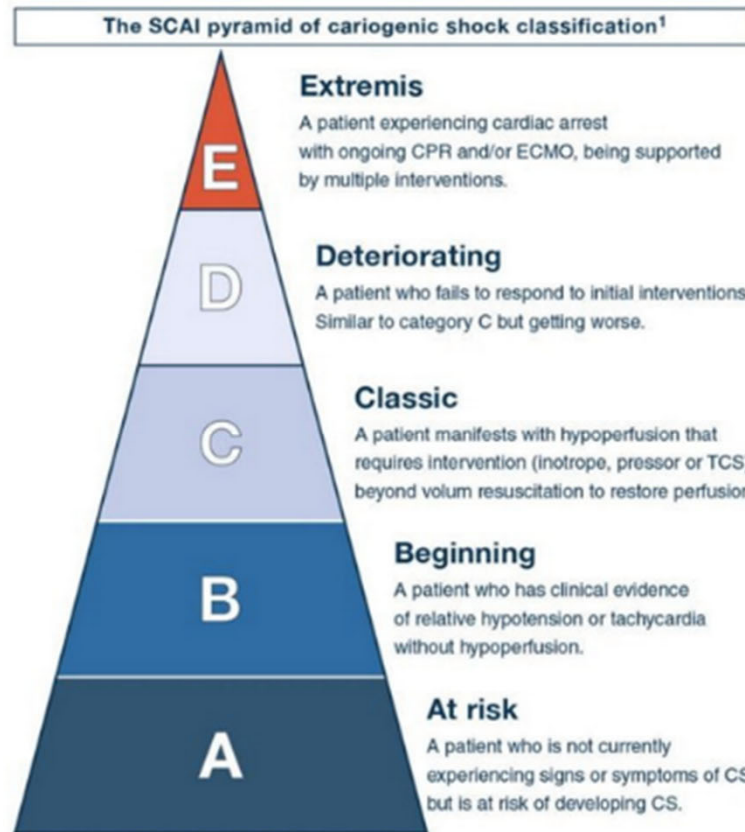
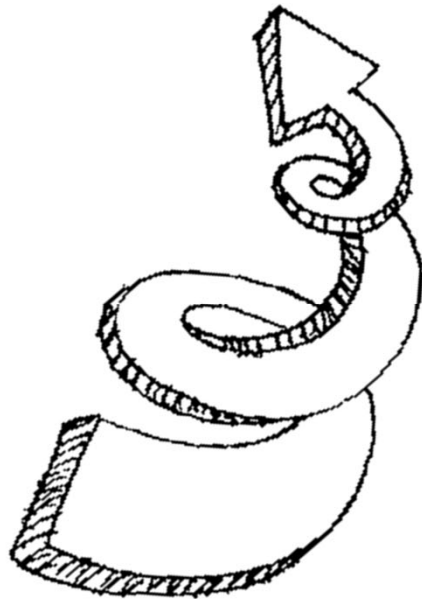

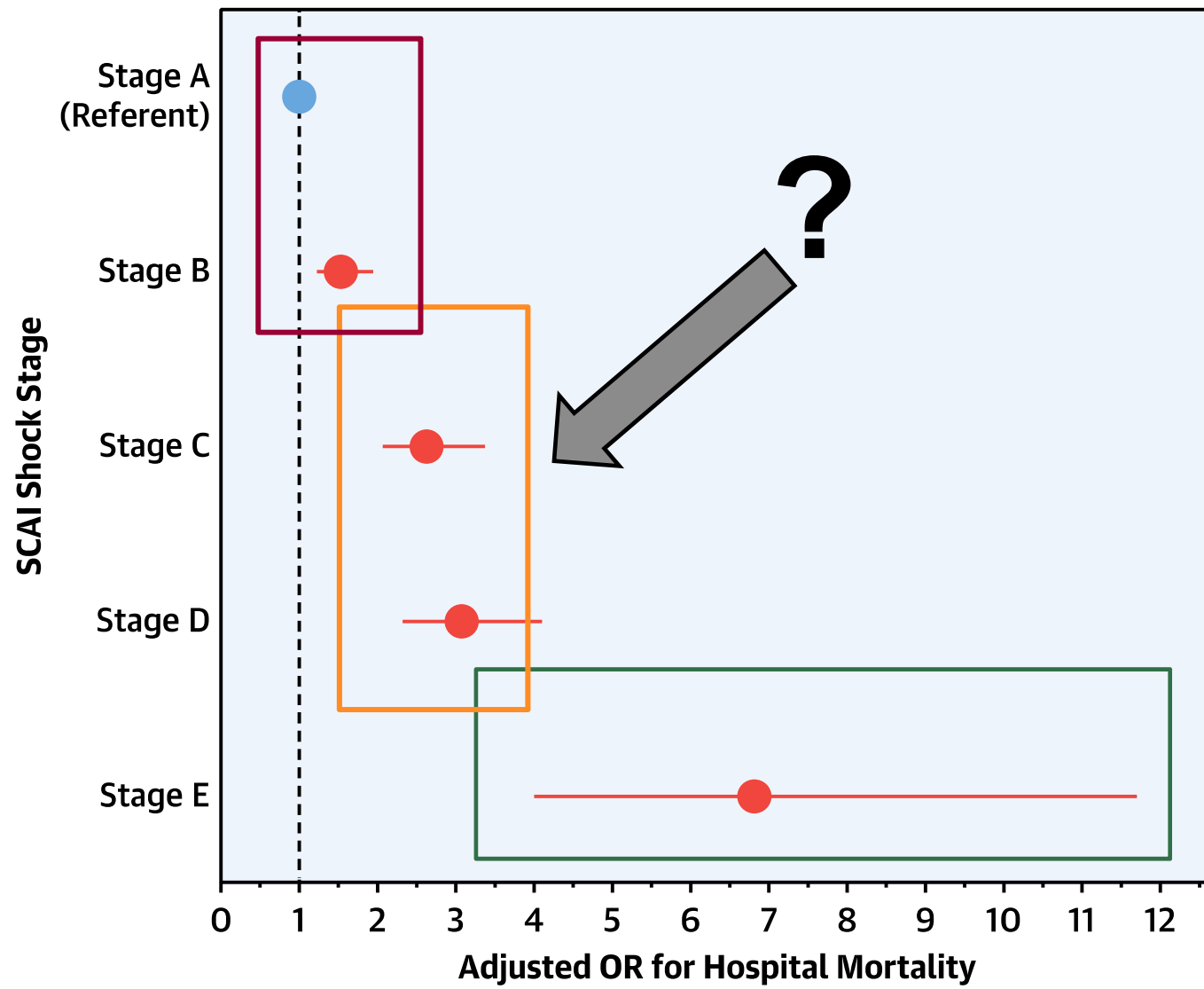

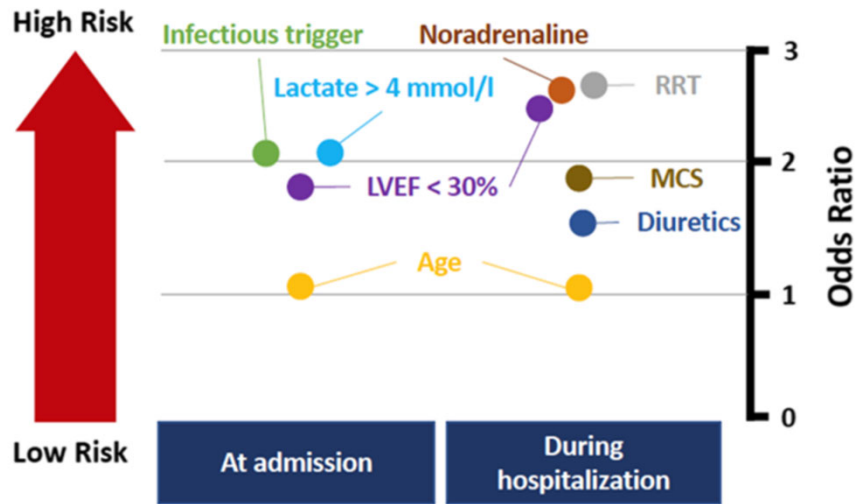

*Delmas C et al. ECS Heart Failure 2022; 9:408-19*

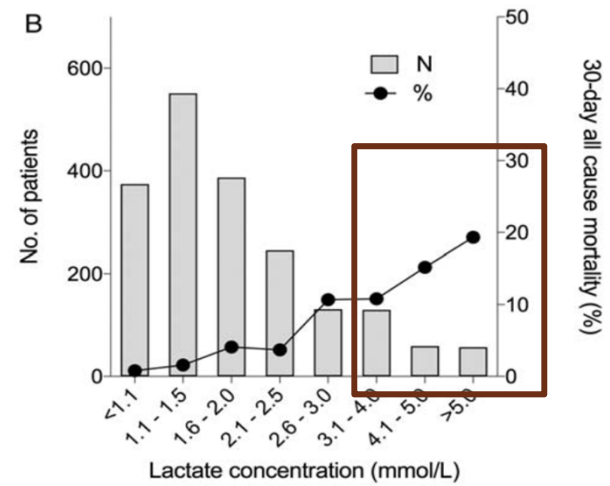

*Frydland M et al. Shock 2019;51:321-7*

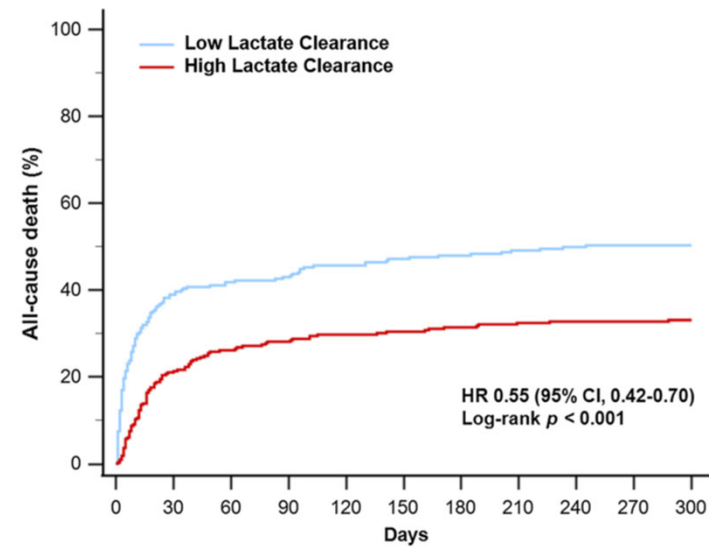

*Park IH et al. J Intensive Care 2021;9:63*

# BY WHO? CARDIOGENIC SHOCK TEAM

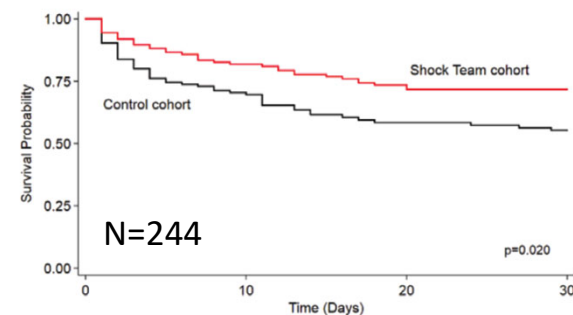
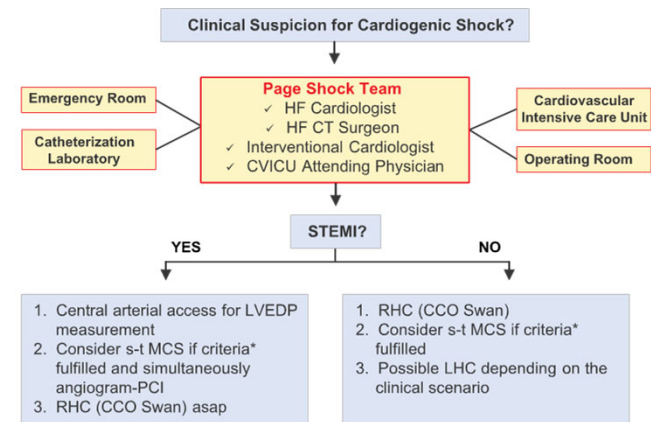
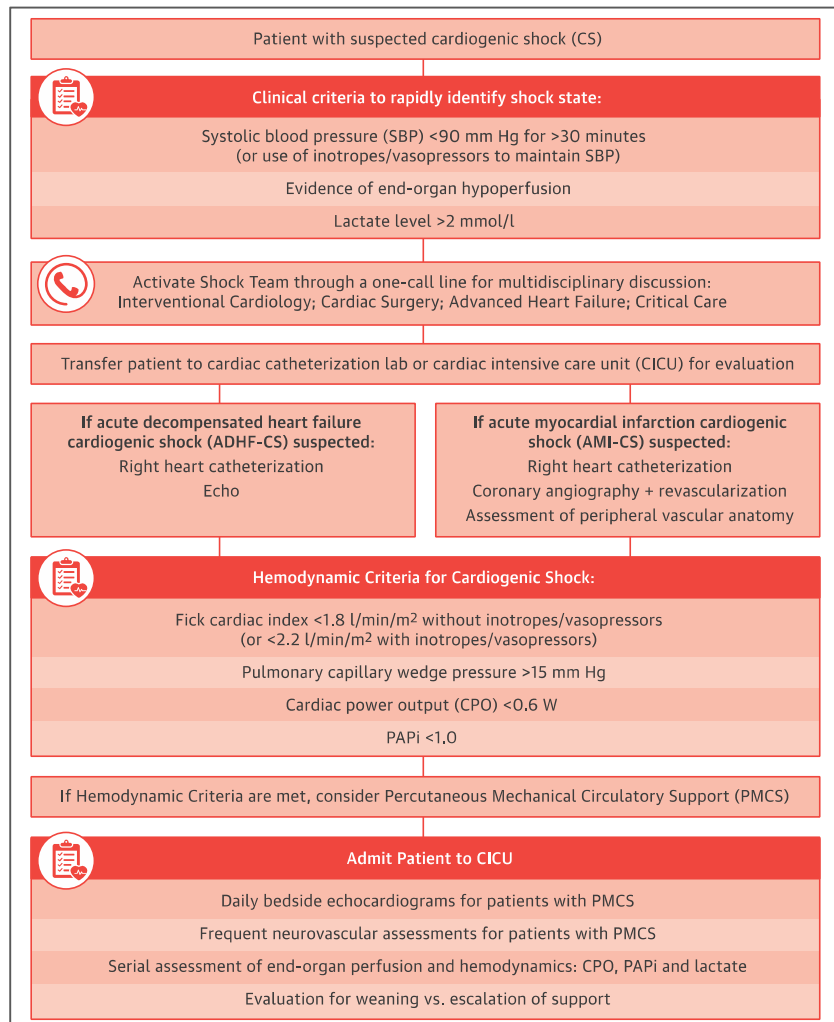

Tehrani BN et al. *J Am Coll Cardiol* 2019; 73:1659-69  
 Taleb I et al. *Circulation* 2019; 140:98-100

# Association of Hospital-Level Volume of Extracorporeal Membrane Oxygenation Cases and Mortality

Analysis of the Extracorporeal Life Support Organization Registry

Barbaro RP et al. Am J Crit Care Med 2015;191:894-901

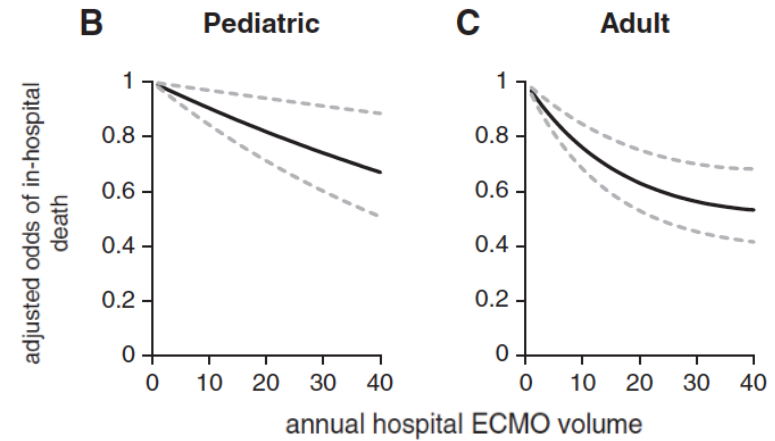
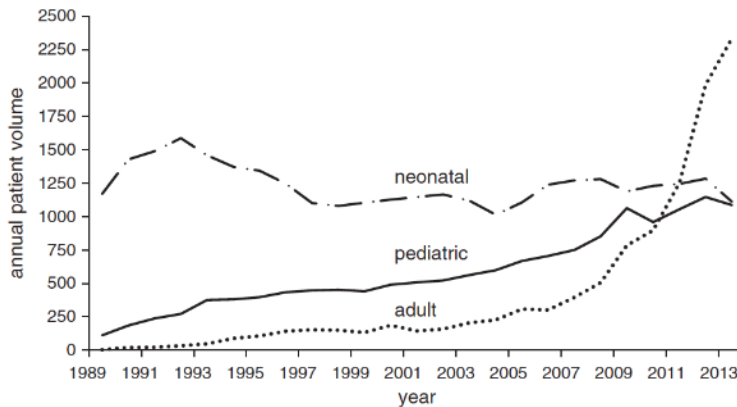

Period	Annual Hospital ECMO Volume	Adjusted Mortality Odds Ratio (95% CI)		
		Neonate	Pediatric	Adult
1989–2013	1–5	Referent	Referent	Referent
	6–14	0.86 (0.75–0.98)	0.99 (0.86–1.13)	0.81 (0.66–0.995)
	15–30	0.74 (0.63–0.88)	0.86 (0.73–1.01)	0.75 (0.59–0.94)
	>30	0.69 (0.56–0.84)	0.89 (0.69–1.14)	0.61 (0.48–0.79)
2008–2013	1–5	Referent	Referent	Referent
	6–14	1.01 (0.79–1.28)	1.03 (0.84–1.25)	0.82 (0.64–1.05)
	15–30	0.94 (0.70–1.25)	0.92 (0.73–1.16)	0.72 (0.55–0.96)
	>30	0.65 (0.42–1.01)	0.85 (0.57–1.28)	0.61 (0.46–0.80)

## Multidisciplinary cardiogenic shock team approach improves the long-term outcomes of patients suffering from refractory cardiogenic shock treated with short-term mechanical circulatory support

François-Xavier Héron<sup>1,2†</sup>, Antoine Beurton<sup>1,2,\*†</sup>, Claire Oddos<sup>1</sup>, Karine Nubret<sup>3</sup>, Clément Aguerreche<sup>1</sup>, Astrid Quessard<sup>1</sup>, Maxime Faure<sup>3</sup>, Edouard Gerbaud<sup>4,5</sup>, Mathieu Pernot<sup>2,6</sup>, Julien Imbault<sup>1,2</sup>, and Alexandre Ouattara<sup>1,2</sup>

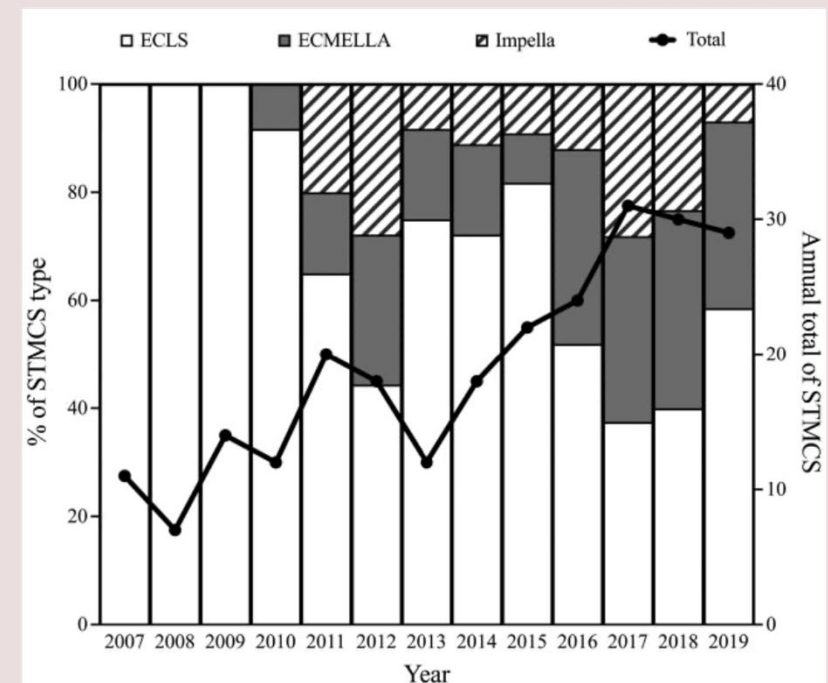
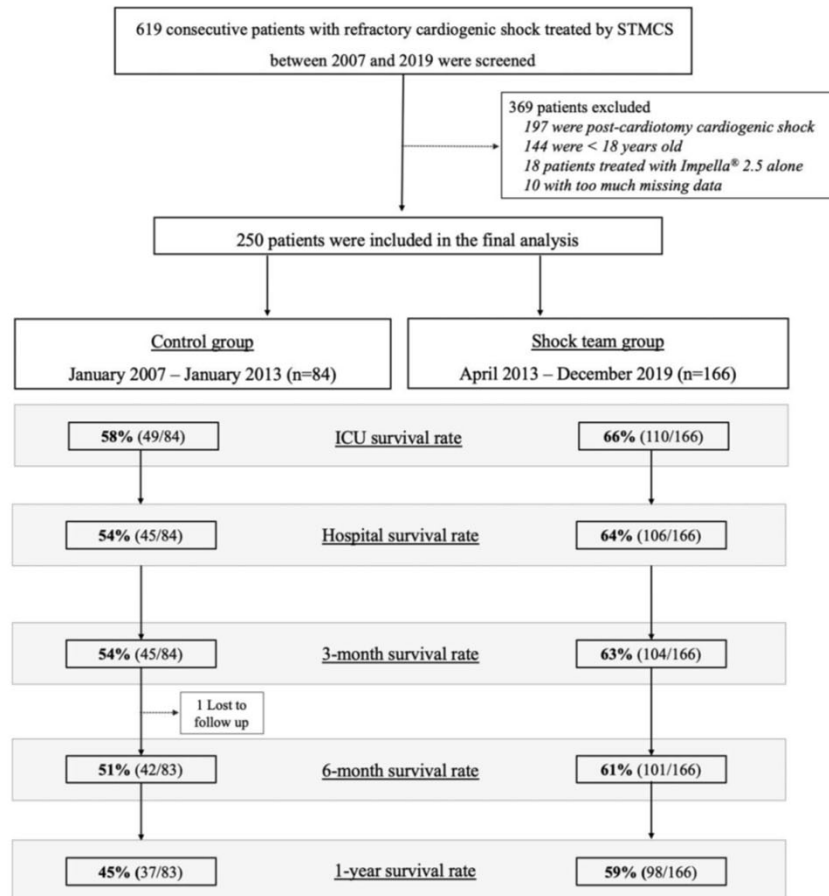

**Figure 3** Trends in STMCS over the years. ECLS, extracorporeal life support; ECMELLA, Association of ECLS and Impella® 2.5, CP or 5.0; IABP, intra-aortic balloon pump; STMCS, short-term mechanical circulatory support. The 'Impella®' category includes only CP and 5.0 used alone.

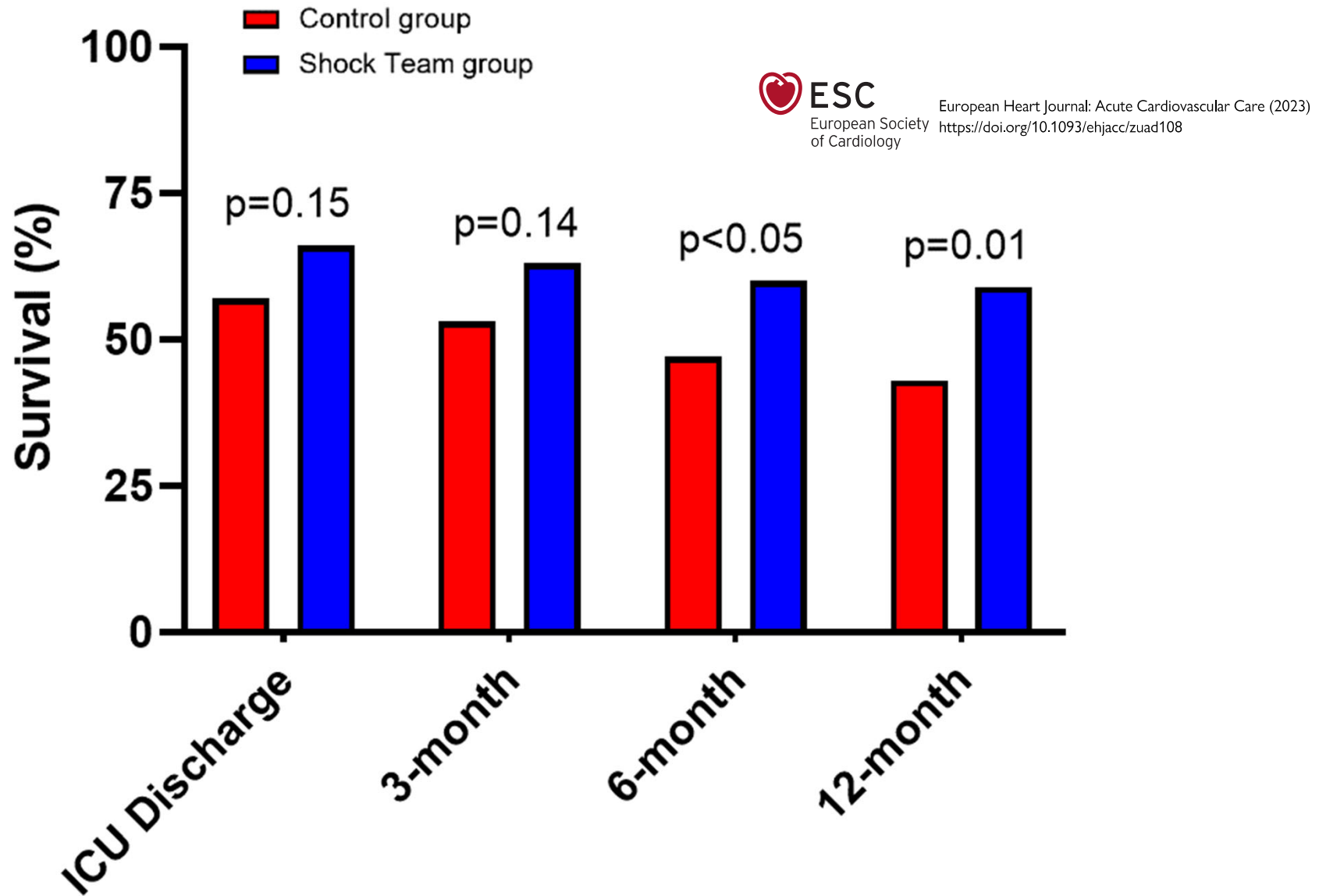

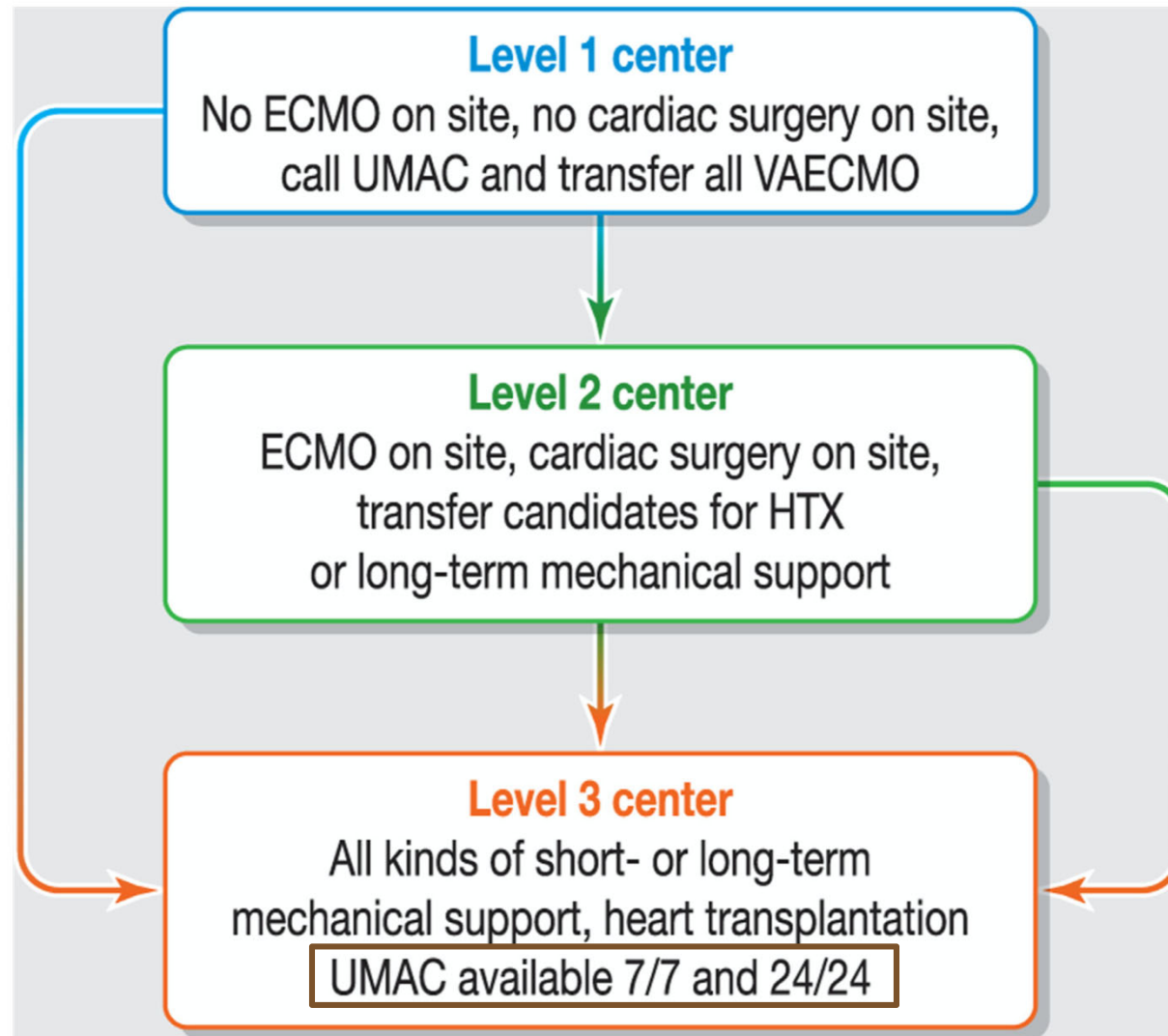

# Short term circulatory support and cardiogenic shock

## IABP-SHOCK II

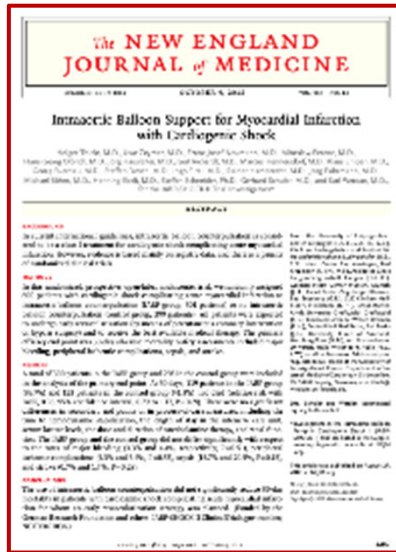

NEJM 2012

## ECMO-CS

Circulation

ORIGINAL RESEARCH ARTICLE

### Extracorporeal Membrane Oxygenation in the Therapy of Cardiogenic Shock: Results of the ECMO-CS Randomized Clinical Trial

Petr Ostada, MD, PhD; Richard Rokyta, MD, PhD; Jiri Kasak, MD, PhD; Andrea Krugic, MD, PhD; Dagmar Vondrakova, MD, PhD; Marek Janota, MD; Jan Naar, MD, PhD; Jana Smalцова, MD; Marketa Hubatova, MSc; Milan Homolka, MD, PhD; Svatopluk Jelinek, MD; Miroslava Seyfrydova, MD; Jiri Jarkovsky, PhD; Michal Svoboda, MSc; Alex Luban, MD, PhD; Jan Babalovsk, MD, PhD, for the ECMO-CS Investigators

**BACKGROUND:** Veno-arterial extracorporeal membrane oxygenation (VA-ECMO) is increasingly being used for circulatory support in patients with cardiogenic shock, although the evidence supporting its use in this context remains insufficient. The ECMO-CS trial (Extracorporeal Membrane Oxygenation in the Therapy of Cardiogenic Shock) aimed to compare immediate implementation of VA-ECMO versus an initially conservative therapy (allowing downstream use of VA-ECMO in patients with rapidly deteriorating or severe cardiogenic shock).

**RESULTS:** This multicenter, randomized, investigator-initiated, academic clinical trial included patients with either rapidly deteriorating or severe cardiogenic shock. Patients were randomly assigned to immediate VA-ECMO or no immediate VA-ECMO. Other diagnostic and therapeutic procedures were performed as per current standards of care. In the early conservative group, VA-ECMO could be used downstream in case of worsening hemodynamic status. The primary end point was the composite of death from any cause, resuscitated circulatory arrest, and implementation of another mechanical circulatory support device at 30 days.

**CONCLUSIONS:** Immediate implementation of VA-ECMO in patients with rapidly deteriorating or severe cardiogenic shock did not improve clinical outcomes compared with an early conservative strategy that permitted downstream use of VA-ECMO in case of worsening hemodynamic status.

**REGISTRATION:** URL: <https://www.clinicaltrials.gov/UniqueIdentifier/NCT02201819>.

**Key Words:** clinical trial ■ shock, cardiogenic ■ therapy

Editorial, see p 465

Correspondence to Petr Ostada, MD, PhD, Cardiovascular Center, Na Homolce Hospital, Romilova 2, 13000 Prague, Czech Republic. Email: [ostada@pfn.cz](mailto:ostada@pfn.cz)

Supplemental Materials, the abstract, and text are available with this article at <https://www.ahajournals.org/doi/suppl/10.1161/CIRCULATIONAHA.122.062949>.

© 2022 American Heart Association, Inc.

Circulation is available at [www.ahajournals.org/journal/circ](http://www.ahajournals.org/journal/circ)

464 February 7, 2023 Circulation 2023;147:464-464. DOI: 10.1161/CIRCULATIONAHA.122.062949

CIRCULATION 2023

## ECLS-SHOCK

THE NEW ENGLAND JOURNAL OF MEDICINE

ORIGINAL ARTICLE

### Extracorporeal Life Support in Infarct-Related Cardiogenic Shock

H. Thiele, U. Zeymer, I. Akin, M. Behnes, T. Rassaf, A.A. Mahabadi, R. Lehmann, I. Eitel, T. Graf, T. Seidler, A. Schuster, C. Skurk, D. Duerschmied, P. Clemmensen, M. Hennerdsdorf, S. Fichtlscherer, I. Voigt, M. Seyfarth, S. John, S. Ewen, A. Linke, E. Tigges, P. Nordbeck, L. Bruch, C. Jung, J. Franz, P. Lauten, T. Goslar, H.-J. Fejzritzler, J. Pöss, E. Kirchhof, T. Ouarak, S. Schneider, S. Desch, and A. Freund, for the ECLS-SHOCK Investigators\*

ABSTRACT

**BACKGROUND:** Extracorporeal life support (ECLS) is increasingly used in the treatment of infarct-related cardiogenic shock despite a lack of evidence regarding its effect on mortality.

**METHODS:** In this multicenter trial, patients with acute myocardial infarction complicated by cardiogenic shock for whom early revascularization was planned were randomly assigned to receive early ECLS plus usual medical treatment (ECLS group) or usual medical treatment alone (control group). The primary outcome was death from any cause at 30 days. Safety outcomes included bleeding, stroke, and peripheral vascular complications warranting interventional or surgical therapy.

**RESULTS:** A total of 420 patients underwent randomization, and 417 patients were included in final analyses. At 30 days, death from any cause had occurred in 100 of 209 patients (47.8%) in the ECLS group and in 102 of 208 patients (49.0%) in the control group (relative risk, 0.98; 95% confidence interval [CI], 0.80 to 1.19; P=0.81). The median duration of mechanical ventilation was 7 days (interquartile range, 4 to 12) in the ECLS group and 5 days (interquartile range, 3 to 9) in the control group (median difference, 1 day; 95% CI, 0 to 2). The safety outcome consisting of moderate or severe bleeding occurred in 23.4% of the patients in the ECLS group and in 9.6% of those in the control group (relative risk, 2.44; 95% CI, 1.50 to 3.95); peripheral vascular complications warranting intervention occurred in 11.0% and 3.8%, respectively (relative risk, 2.86; 95% CI, 1.31 to 6.25).

**CONCLUSIONS:** In patients with acute myocardial infarction complicated by cardiogenic shock with planned early revascularization, the risk of death from any cause at the 30-day follow-up was not lower among the patients who received ECLS therapy than among those who received medical therapy alone. (Funded by the Else Kröner Fresenius Foundation and others; ECLS-SHOCK ClinicalTrials.gov number, NCT019637205.)

NEJM 2023

## DANGER

THE NEW ENGLAND JOURNAL OF MEDICINE

ORIGINAL ARTICLE

### Microaxial Flow Pump or Standard Care in Infarct-Related Cardiogenic Shock

J. E. Møller, T. Engstrøm, L.O. Jensen, H. Eiskjær, N. Mangner, A. Polzin, P.C. Schulze, C. Skurk, P. Nordbeck, P. Clemmensen, V. Panoulas, S. Zimmer, A. Schäfer, N. Werner, M. Frydland, L. Holmvang, J. Kjærgaard, R. Sørensen, J. Lanborg, M.G. Lindholm, N.L.J. Udesen, A. Junker, H. Schmidt, C.J. Terkelsen, S. Christensen, E.H. Christiansen, A. Linke, F.J. Woitek, R. Westenfeld, S. Möbius-Winkler, H.B. Ravin, J.F. Lassen, S. Boesgaard, O. Gerke, and C. Hassager, for the DanGer Shock Investigators\*

ABSTRACT

**BACKGROUND:** The effects of temporary mechanical circulatory support with a microaxial flow pump on mortality among patients with ST-segment elevation myocardial infarction (STEMI) complicated by cardiogenic shock remains unclear.

**METHODS:** In an international, multicenter, randomized trial, we assigned patients with STEMI and cardiogenic shock to receive a microaxial flow pump (Impella CP) plus standard care or standard care alone. The primary end point was death from any cause at 180 days. A composite safety end point was severe bleeding, limb ischemia, hemolysis, device failure, or worsening aortic regurgitation.

**RESULTS:** A total of 360 patients underwent randomization, of whom 355 were included in the final analysis (179 in the microaxial-flow-pump group and 176 in the standard-care group). The median age of the patients was 67 years, and 79.2% were men. Death from any cause occurred in 82 of 179 patients (45.8%) in the microaxial-flow-pump group and in 103 of 176 patients (58.5%) in the standard-care group (hazard ratio, 0.74; 95% confidence interval [CI], 0.55 to 0.99; P=0.04). A composite safety end-point event occurred in 43 patients (24.0%) in the microaxial-flow-pump group and in 11 (6.2%) in the standard-care group (relative risk, 4.74; 95% CI, 2.36 to 9.55). Renal-replacement therapy was administered to 75 patients (41.9%) in the microaxial-flow-pump group and to 47 patients (26.7%) in the standard-care group (relative risk, 1.98; 95% CI, 1.27 to 3.09).

**CONCLUSIONS:** The routine use of a microaxial flow pump with standard care in the treatment of patients with STEMI-related cardiogenic shock led to a lower risk of death from any cause at 180 days than standard care alone. The incidence of a composite of adverse events was higher with the use of the microaxial flow pump. (Funded by the Danish Heart Foundation and Abiomed; DanGer Shock ClinicalTrials.gov number, NCT01633952.)

NEJM 2024

# Evidence-based medicine...?

ECLS

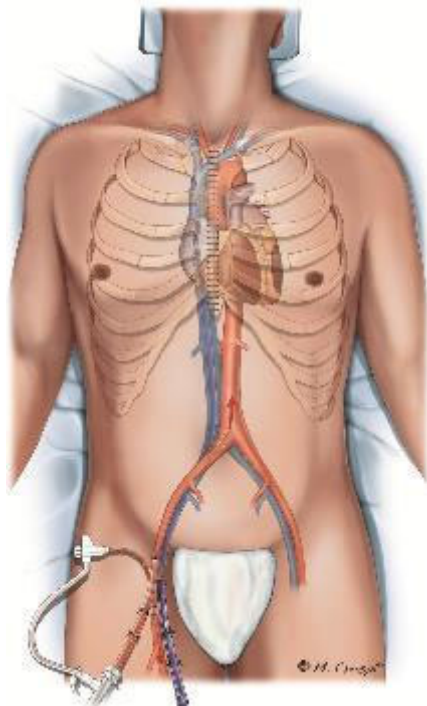

Lamarche Y et al. J Throac Cardiovasc Surg 2011  
 Karami M et al. Eur Heart J Acute Cardiovasc Care 2019  
 Garan AR et al. J Am Heart Assoc. 2019

ou



et

Pappalardo F et al. Eur J Heart Fail. 2017  
 Patel SM et al. ASAIO Journal 2019

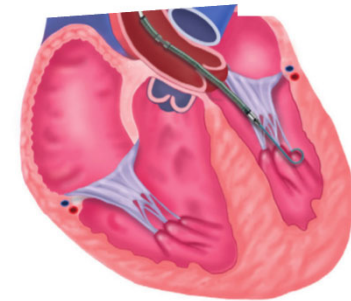

C. All-c

60

Ouweneel DM et al. JAAC 2017; 69:278-87

Schrage B et al. Circulation 2019; 139:1249-58

Vallabhajosyula S et al. Circ Cardiovascular Interv 2018  
 Aso S et al. Crit Care Med 2016

+

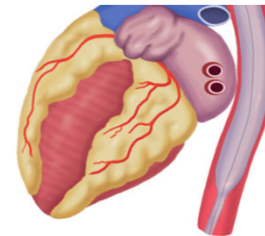

Mortality, ≤6 Months

ndomization

Doll N et al. Ann Thorac Surg 2004;77:151-7  
 Riebandt J et al. Eur J Cardiothorac Surg 2014; 46:486-92

Thiele H et al. N Engl J Med 2012;367:1287-96



# Extracorporeal Membrane Oxygenation in the Therapy of Cardiogenic Shock: Results of the ECMO-CS Randomized Clinical Trial

Ostadal P et al. *Circulation* 2023; 147:454–64

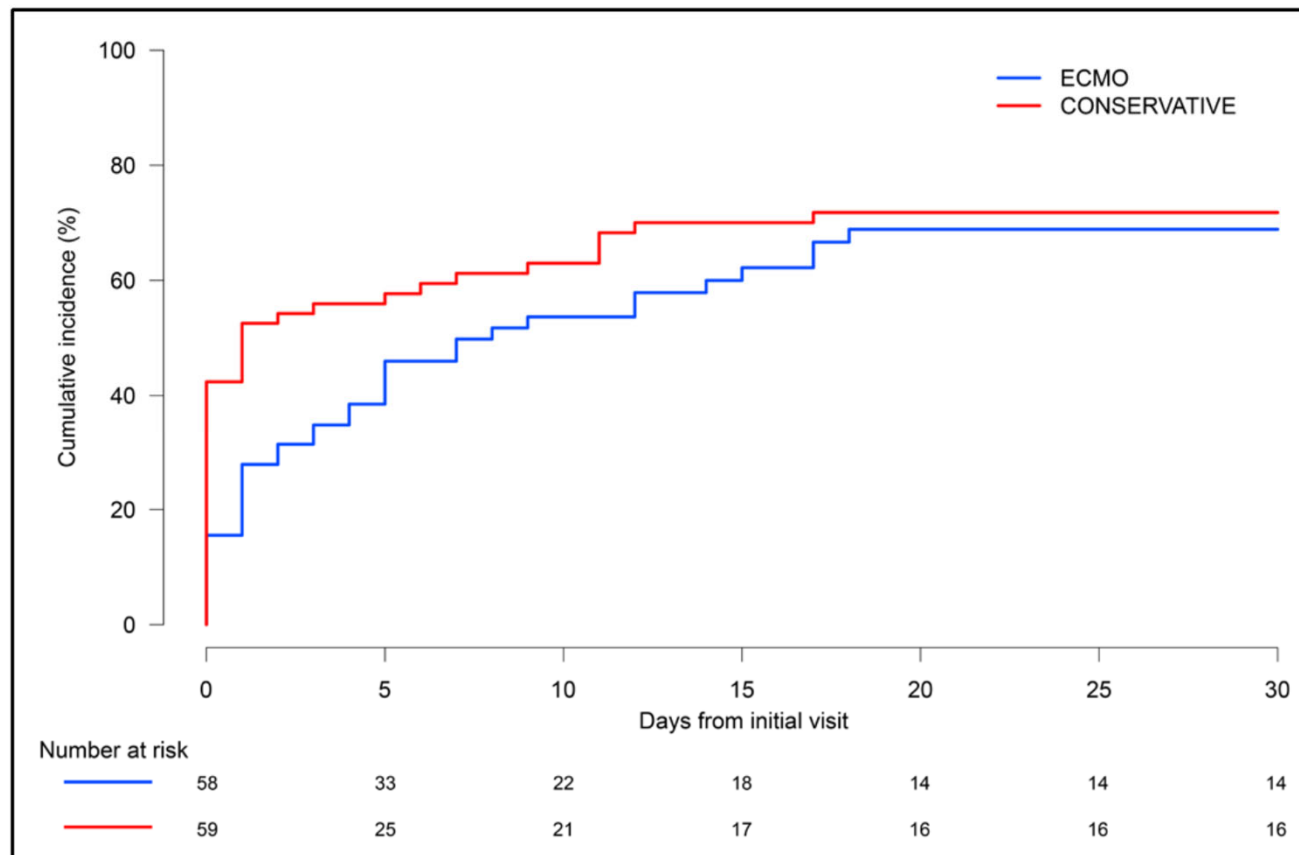

# Extracorporeal Life Support in Infarct-Related Cardiogenic Shock

H. Thiele, U. Zeymer, I. Akin, M. Behnes, T. Rassaf, A.A. Mahabadi, R. Lehmann, I. Eitel, T. Graf, T. Seidler, A. Schuster, C. Skurk, D. Duerschmied, P. Clemmensen, M. Hennesdorf, S. Fichtlscherer, I. Voigt, M. Seyfarth, S. John, S. Ewen, A. Linke, E. Tigges, P. Nordbeck, L. Bruch, C. Jung, J. Franz, P. Lauten, T. Goslar, H.-J. Feistritz, J. Pöss, E. Kirchhof, T. Ouarrak, S. Schneider, S. Desch, and A. Freund, for the ECLS-SHOCK Investigators\*

## Design

- Prospective, randomized multicentre study (Slovenia and Germany)
- AMI complicated by CS (SAP<90 mmHg and lactate>3) early revascularized (PCI or CABG)
- SCAI C to E requiring early use of ECLS after coronarography
- Crossover to ECLS was possible
- Primary outcome: all cause death at D30

## Results

- Inclusion period 2019 to 2022 (44 centers) n=417
- Cross over from control to ECLS group for n=26

Characteristic	ECLS (N=209)	Control (N=208)
SCAI shock stage — no. (%)‡		
C	104 (49.8)	111 (53.4)
D	38 (18.2)	18 (8.7)
E	67 (32.1)	79 (38.0)
Catheterization access — no./total no. (%)		
Femoral	156/208 (75.0)	148/207 (71.5)
Radial	52/208 (25.0)	59/207 (28.5)
Type of revascularization — no./total no. (%)		
PCI	199/208 (95.7)	199/204 (97.5)
CABG	1/208 (0.5)	0/204
PCI with transfer to CABG	2/208 (1.0)	0/204
No revascularization	6/208 (2.9)	5/204 (2.5)
ECLS therapy — no. (%)	192 (91.9)	26 (12.5)
Initiation in catheterization laboratory		
Before revascularization	42/192 (21.9)	4/26 (15.4)
During revascularization	50/192 (26.0)	8/26 (30.8)
After revascularization	100/192 (52.1)	7/26 (26.9)
Median duration of ECLS therapy (IQR) — days	2.7 (1.5–4.8)	2.7 (2.2–3.8)
Resuscitation before randomization — no. (%)	162 (77.5)	162 (77.9)

Characteristic	ECLS (N = 209)	Control (N = 208)
Target temperature management — no./total no. (%)	82/209 (39.2)	109/208 (52.4)
Invasive mechanical ventilation		
Patients — no./total no. (%)	183/203 (90.1)	177/202 (87.6)
Median duration (IQR) — days	7.0 (4.0–12.0)	5.0 (3.0–9.0)
Catecholamine requirement — no./total no. (%)	203/209 (97.1)	195/208 (93.8)
Norepinephrine	181/203 (89.2)	181/195 (92.8)
Epinephrine	63/203 (31.0)	69/195 (35.4)
Dobutamine	88/203 (43.3)	59/195 (30.3)
Dopamine	1/203 (0.5)	0/195
Sepsis within 30 days after randomization — no. (%)	21 (10.0)	21 (10.1)
Intraaortic balloon pump	—	1/28 (3.6)
Impella 2.5	—	1/28 (3.6)
Impella CP	—	24/28 (85.7)
Impella 5.0	—	1/28 (3.6)
Impella 5.5	—	1/28 (3.6)
Permanent left ventricular assist device — no./total no. (%)	1 (0.5)	1 (0.5)

	<b>ECLS</b>	<b>Control</b>
	<b>(n=209)</b>	<b>(n=208)</b>
<b>All-cause mortality at 30 days; n/total (%)</b>	100/209 (47.8)	102/208 (49.0)
<b>Causes of death at 30 days</b>		
Refractory cardiogenic shock, n/total (%)	51/100 (51.0)	56/102 (54.9)
Sudden cardiac death; n/total (%)	7/100 (7.0)	5/102 (4.9)
Recurrent myocardial infarction; n/total (%)	2/100 (2.0)	2/102 (2.0)
Mechanical complication of infarction; n/total (%)	1/100 (1.0)	1/102 (1.0)
Bleeding; n/total (%)	4/100 (4.0)	0/102
Brain injury; n/total (%)	26/100 (26.0)	27/102 (26.5)
Sepsis; n/total (%)	4/100 (4.0)	10/102 (9.8)
Unknown cause; n/total (%)	0/100	1/102 (1.0)
Other cause; n/total (%)	5/100 (5.0)	0/102

	<b>ECLS</b>	<b>Control</b>
	<b>(n=209)</b>	<b>(n=208)</b>
Active left ventricular unloading during ECLS therapy;	11/190 (5.8)	6/19 (31.6)

Type of unloading; n/total (%)

Additional insertion of IABP	2/11 (18.2)	2/6 (33.3)
Additional insertion of percutaneous left ventricular assist device (Impella®)	9/11 (81.8)	4/6 (66.7)
Atrial septostomy with drainage of the left atrium by a pigtail catheter connected to the venous cannula of the ECLS	0/11	0/6
Pulmonary artery drainage with connection to the venous cannula of the ECLS	0/11	0/6
Transaortic venting by pigtail catheter insertion into the left ventricle and connection to the venous cannula of the ECLS	0/11	0/6

## 2021 ESC Guidelines for the diagnosis and treatment of acute and chronic heart failure

Recommendations	Class <sup>a</sup>	Level <sup>b</sup>
Short-term MCS should be considered in patients with cardiogenic shock as a BTR, BTD, BTB. Further indications include treatment of the cause of cardiogenic shock or long-term MCS or transplantation.	<b>IIa</b>	<b>C</b>
IABP may be considered in patients with cardiogenic shock as a BTR, BTD, BTB, including treatment of the cause of cardiogenic shock (i.e. mechanical complication of acute MI) or long-term MCS or transplantation. <sup>450</sup>	<b>IIb</b>	<b>C</b>
IABP is not routinely recommended in post-MI cardiogenic shock. <sup>500–502</sup>	<b>III</b>	<b>B</b>

# Extracorporeal Membrane Oxygenation in Cardiopulmonary Disease in Adults



Abrams D et al. *J Am Coll Cardiol* 2014; 63:2769-78

- Rescue therapy (no first line)
- Refractory cardiogenic shock
- Respiratory and/or cardiac supply
- Ensure “optimal” peripheral organs perfusion
- Cardiac function recovery (+++)
- Left ventricular loading conditions
- Coronary perfusion and myocardial working
- No influence on myocardial recovery (+++)

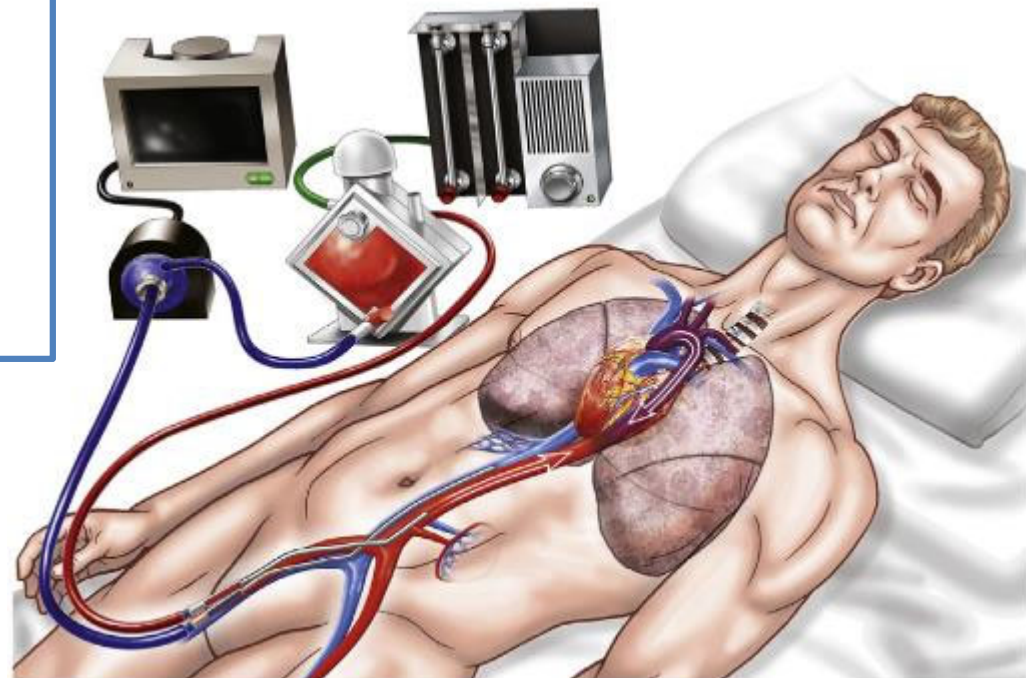

Dennis M JAHA 2020

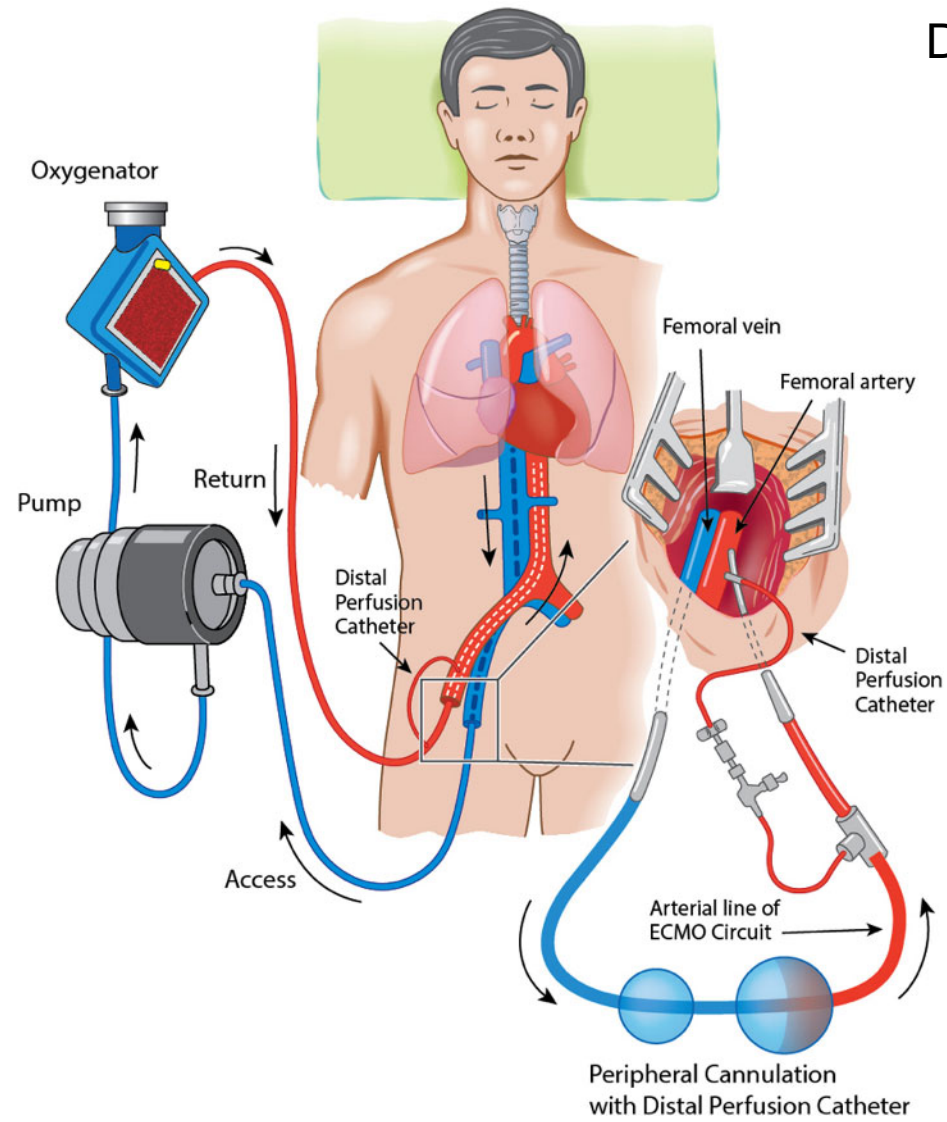



## Several advantages...

- Respiratory and/or cardiac supply
- Biventricular supply (including right ventricular dysfunction)
- Restore peripheral end-organ perfusion by providing high flow (up to 7 L.min<sup>-1</sup>)
- Rapid insertion (cardiac arrest...)
- Peripheral cannulation (femoral access)
- Cheap and easily reliable
- Biventricular supply
- Mobile

# INDICATIONS



- Post-cardiotomy (conventional or heart transplantation)
  - Immediately when the CPB weaning appears to be impossible
  - Secondary in presence of refractory Low cardiac output syndromue

*Bakhtiari F et al. J Thorac Cardiovasc Surg 2008;135:382-8*

*Rastan AJ et al. J Thorac Cardiovasc Sug 2010; 139:302-11*

- Medical indications

- Myocardial infarction Infarctus du myocarde
- Dilated cardiomyopathy
- Acute Myocarditis fulminante
- CIntoxication médicamenteuse cardio-toxiques
- Pulmonary Cœur pulmonaire aigue (embolie pulmonaire, embolie amniotique)
- Accidental hypothermia (noyade)

*Marasco SF et al. Heart, Lung and Circulation 2008; 17:S41-7*

*Baud F et al. Crit Care 2007;11:207*

# CONTRE-INDICATIONS

## CRITÈRES MAJEURS

MULTI-ORGAN DYSFUNCTION (SOFA > 15)

AGE > 70 YR

CARDIAC ARREST (LOW-FLOW > 90', NO-FLOW > 10', ETCO<sub>2</sub> < 10 MMHG, PAS DE SIGNE DE VIE ET ASYSTOLIE)

ABOSOLUTE COUNTER-INDICATION TO ANTICOAGULATION THERAPY

## CRITÈRES MINEURS

CO-MORBIDITIES (RENAL, PULMONARY OR NEURO)

STROKE

PH < 7.0

LACTATE LEVEL > 15 MMOL/L

SVO<sub>2</sub> < 33%

Discussion multi-disciplinaire ++++

# Outcomes and long-term quality-of-life of patients supported by extracorporeal membrane oxygenation for refractory cardiogenic shock\*

Crit Care Med 2008; 36:1404–1411

Alain Combes, MD, PhD; Pascal Leprince, MD, PhD; Charles-Edouard Luyt, MD, PhD; Nicolas Bonnet, MD; Jean-Louis Trouillet, MD; Philippe Léger, MD; Alain Pavie, MD; Jean Chastre, MD

Table 4. Multivariable logistic-regression analysis: early independent predictors of intensive care unit death

Factor	OR (95% CI)	<i>p</i>
Female sex	3.89 (1.06–14.22)	.04
Myocarditis	0.13 (0.02–0.78)	.03
ECMO under CPR	20.68 (1.09–392.03)	.04
Prothrombin activity <50%	3.93 (1.11–13.85)	.03
24-hr urine output <500 mL	6.52 (1.87–22.74)	.003

OR, odds ratio; CI, confidence interval; CPR, cardiopulmonary resuscitation; ECMO, extracorporeal membrane oxygenation.

# Extracorporeal Life Support Organization Registry Report 2012

MATTHEW L. PADEN,\* STEVEN A. CONRAD,† PETER T. RYCUS,‡ AND RAVI R. THIAGARAJAN§, ON BEHALF OF THE ELSO REGISTRY

*ASAIO Journal* 2013;59:202–210

**Table 7. Mechanical and Patient-related Complications for Cardiac ECLS**

	0–30 Days	31 Days and <1 Year	1 Year and <16 Years	>16 Years
<b>Mechanical</b>				
Oxygenator failure	7.4 (24)	8.1 (29)	9 (43)	15.1 (36)
Tubing rupture	0.3 (25)	0.6 (50)	0.7 (47)	0.2 (0)
Pump malfunction	1.6 (29)	2.1 (35)	2.1 (50)	0.7 (28)
Cannula problems	6.1 (33)	5.6 (38)	6.3 (42)	4.4 (27)
<b>Patient-related</b>				
ICH	11.3 (23)	5.7 (29)	3.8 (21)	1.7 (7)
Cannula site bleeding	10.4 (30)	11.9 (40)	17.6 (52)	20.9 (39)
Surgical site bleeding	31.7 (30)	33 (39)	28.8 (48)	25.5 (34)
Cardiac tamponade	6.1 (27)	5.1 (38)	5.1 (50)	5.7 (27)
Clinical seizures	7.3 (29)	9 (26)	4.5 (21)	2.1 (15)

Table entries are reported in percentage (% survival).  
ECLS, extracorporeal life support; ICH, intracranial hemorrhage.

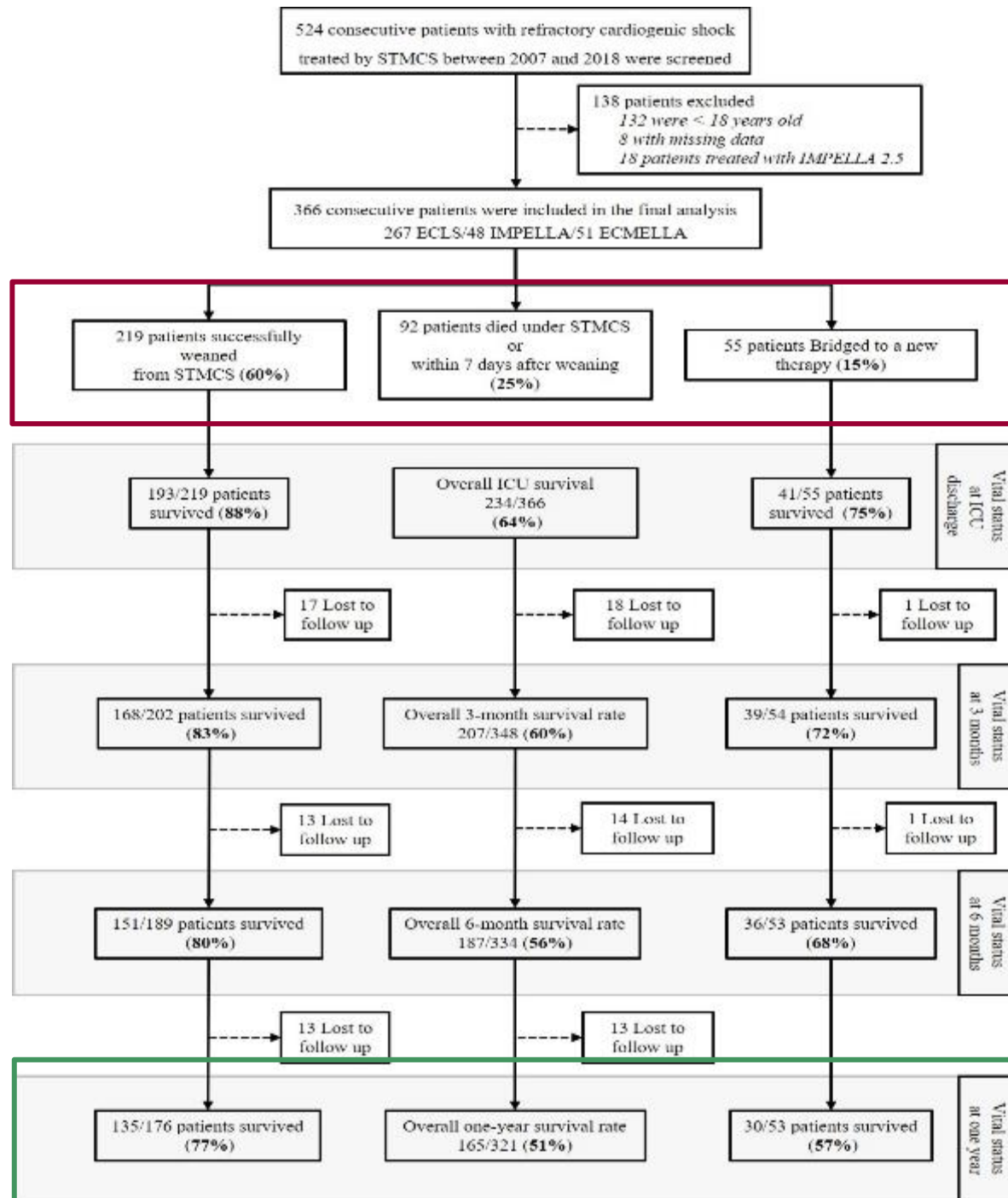

# Peripheral veno-arterial ECLS

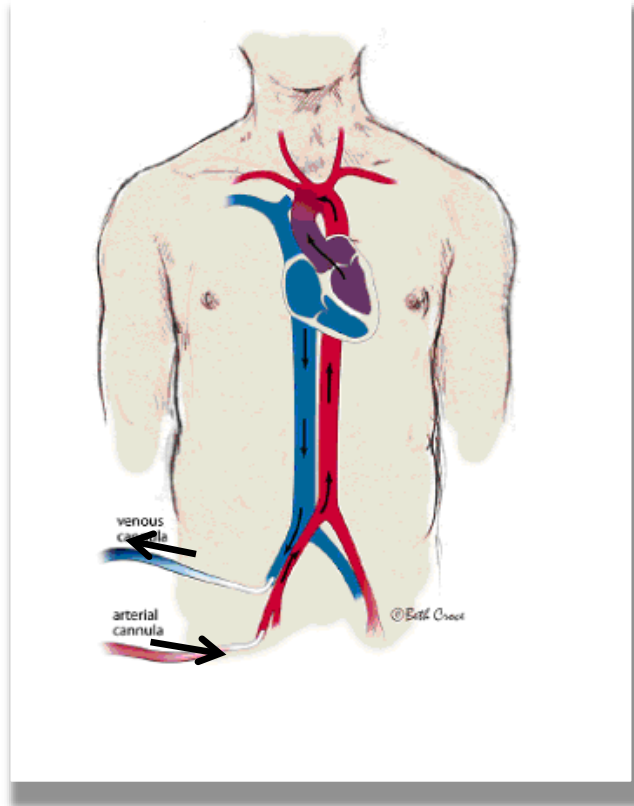

Retrograde aortic flow in total competition with native stream

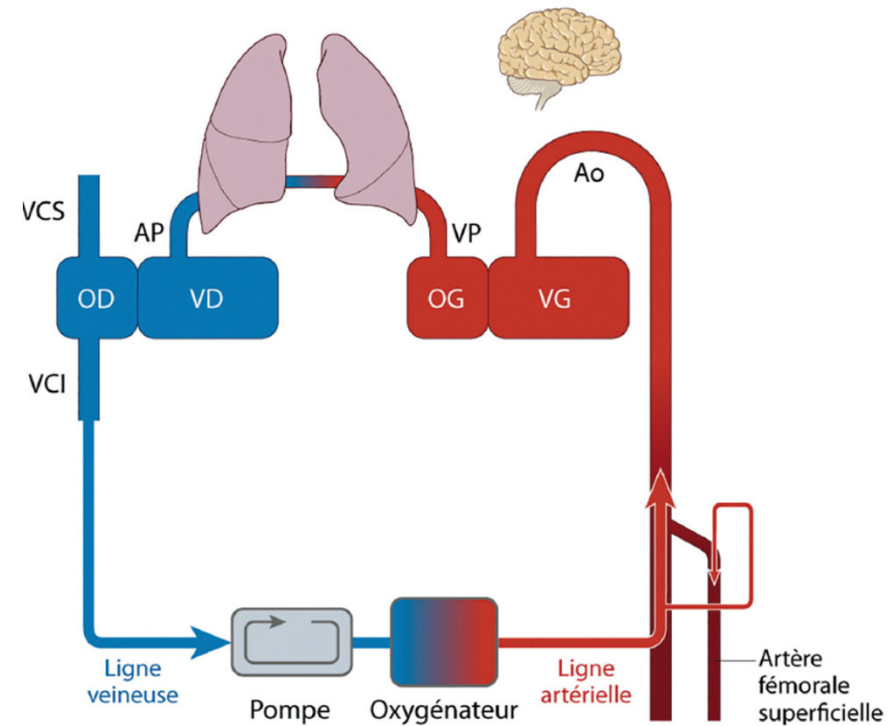

# Central veno-arterial ECLS

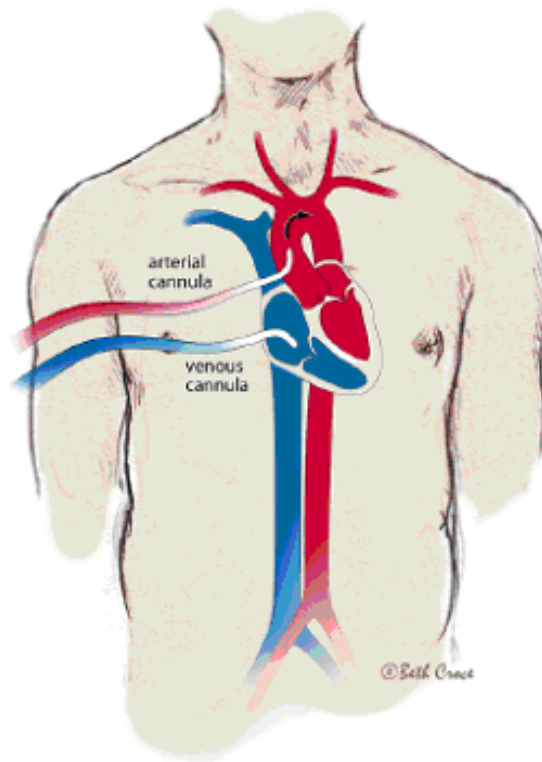

**Central ECLS  
(anterograde flow)**

# PRINCIPES DE L'ECLS

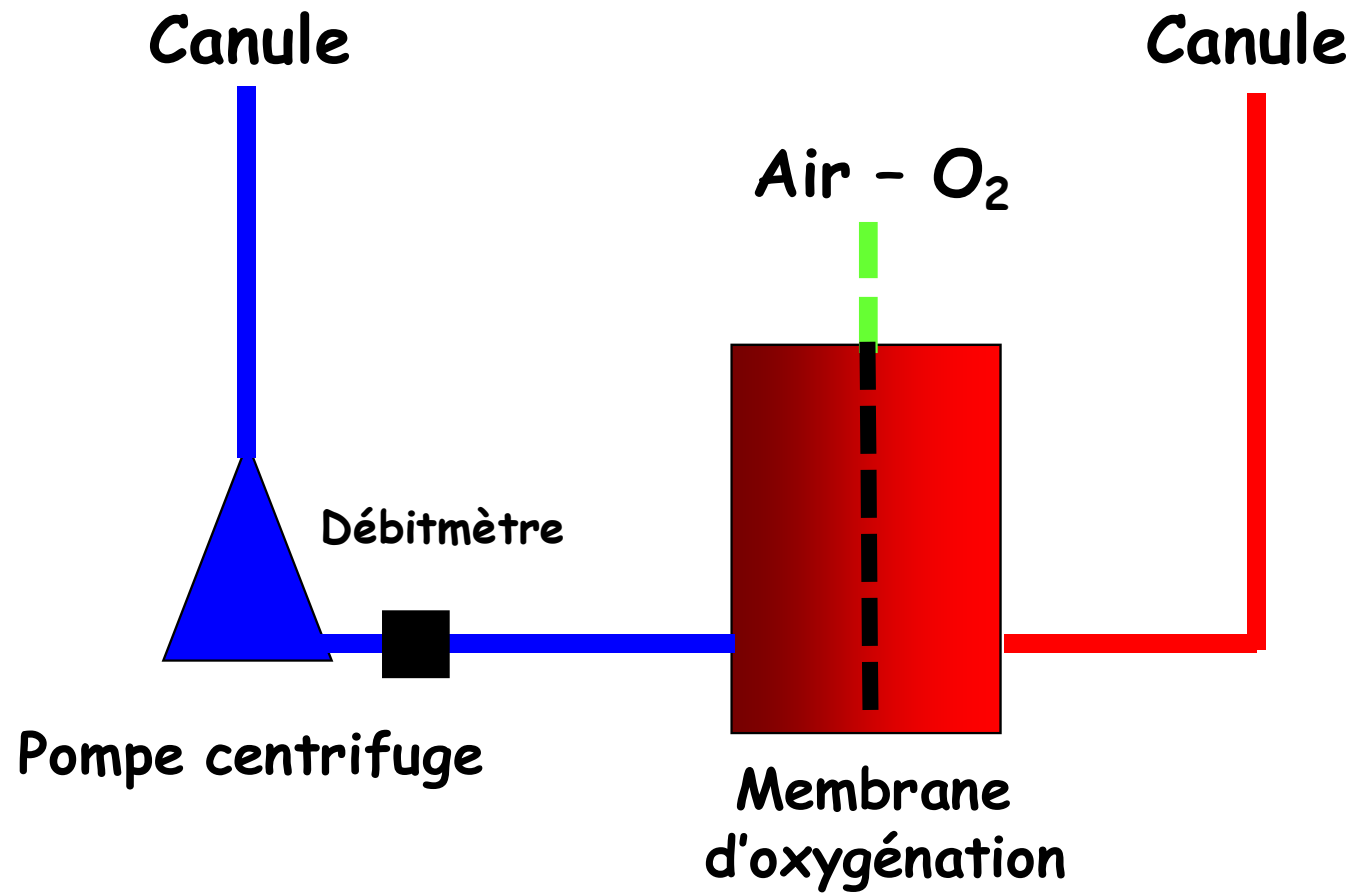



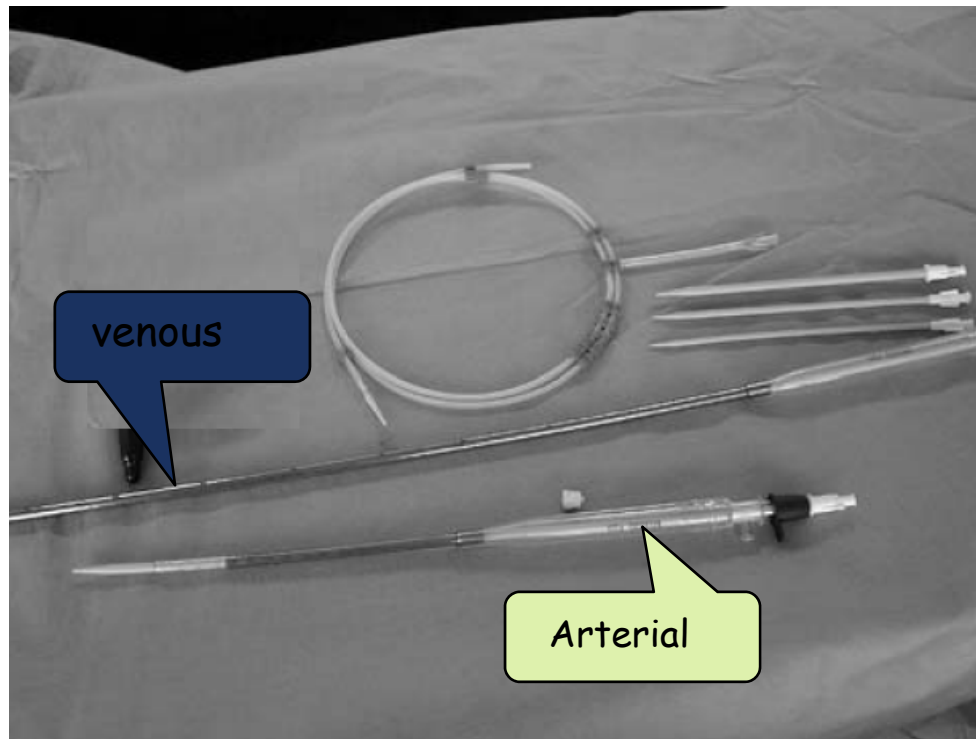

Percutaneous at the bedside (echography guided +++ ) or surgical way  
Preferentially removed in operating room ++++

## Informations de commande des canules HLS artérielles

Type	Diamètre extérieur	Longueur d'insertion	Orifices latéraux	Longueur de perforation	Connexion	Revêtement Bioline
PAS 1315	13 Fr (4,3 mm)	15 cm	2	1 cm	3/8" LL	BE-PAS 1315
PAS 1515	15 Fr (5,0 mm)	15 cm	2	1 cm	3/8" LL	BE-PAS 1515
PAS 1715	17 Fr (5,7 mm)	15 cm	2	1 cm	3/8" LL	BE-PAS 1715
PAS 1915	19 Fr (6,3 mm)	15 cm	2	1 cm	3/8" LL	BE-PAS 1915
PAS 2115	21 Fr (7,0 mm)	15 cm	2	1 cm	3/8" LL	BE-PAS 2115
PAS 2315	23 Fr (7,7 mm)	15 cm	2	1 cm	3/8" LL	BE-PAS 2315
PAL 1523	15 Fr (5,0 mm)	23 cm	2	1 cm	3/8" LL	BE-PAL 1523
PAL 1723	17 Fr (5,7 mm)	23 cm	2	1 cm	3/8" LL	BE-PAL 1723
PAL 1923	19 Fr (6,3 mm)	23 cm	2	1 cm	3/8" LL	BE-PAL 1923
PAL 2123	21 Fr (7,0 mm)	23 cm	2	1 cm	3/8" LL	BE-PAL 2123
PAL 2323	23 Fr (7,7 mm)	23 cm	2	1 cm	3/8" LL	BE-PAL 2323



## Informations de commande des canules HLS veineuses

Type	Diamètre extérieur	Longueur d'insertion	Orifices latéraux	Longueur de perforation	Connexion	Revêtement Bioline
PVS 1938	19 Fr (6,3 mm)	38 cm	12	10 cm	3/8"	BE-PVS 1938
PVS 2138	21 Fr (7,0 mm)	38 cm	12	10 cm	3/8"	BE-PVS 2138
PVS 2338	23 Fr (7,7 mm)	38 cm	16	10 cm	3/8"	BE-PVS 2338
PVS 2538	25 Fr (8,3 mm)	38 cm	20	10 cm	3/8"	BE-PVS 2538
PVL 2155	21 Fr (7,0 mm)	55 cm	20	20 cm	3/8"	BE-PVL 2155
PVL 2355	23 Fr (7,7 mm)	55 cm	20	20 cm	3/8"	BE-PVL 2355
PVL 2555	25 Fr (8,3 mm)	55 cm	24	20 cm	3/8"	BE-PVL 2555
PVL 2955	29 Fr (9,7 mm)	55 cm	32	20 cm	3/8"	BE-PVL 2955



### Arterial

Pressure Drop vs. Flow

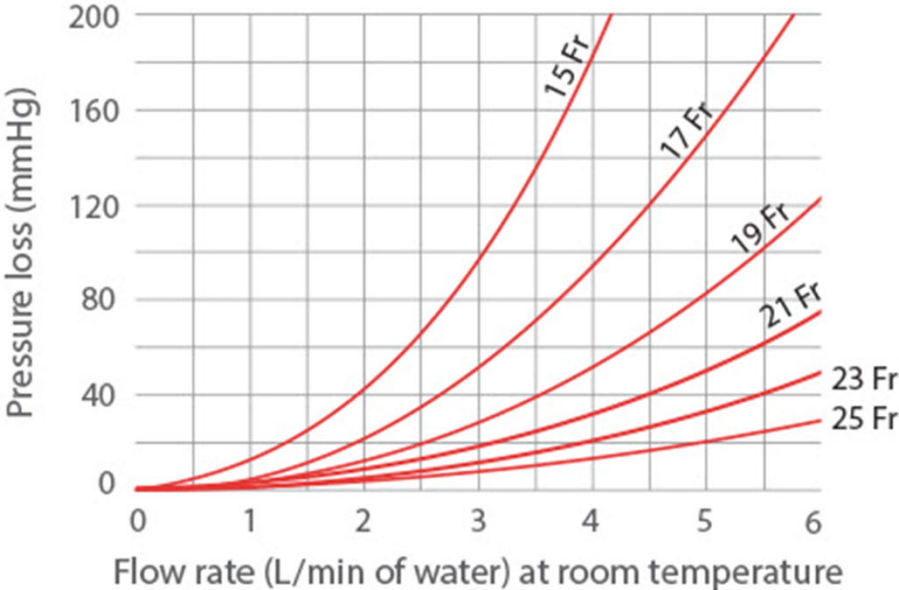

### Venous

Pressure Drop vs. Flow

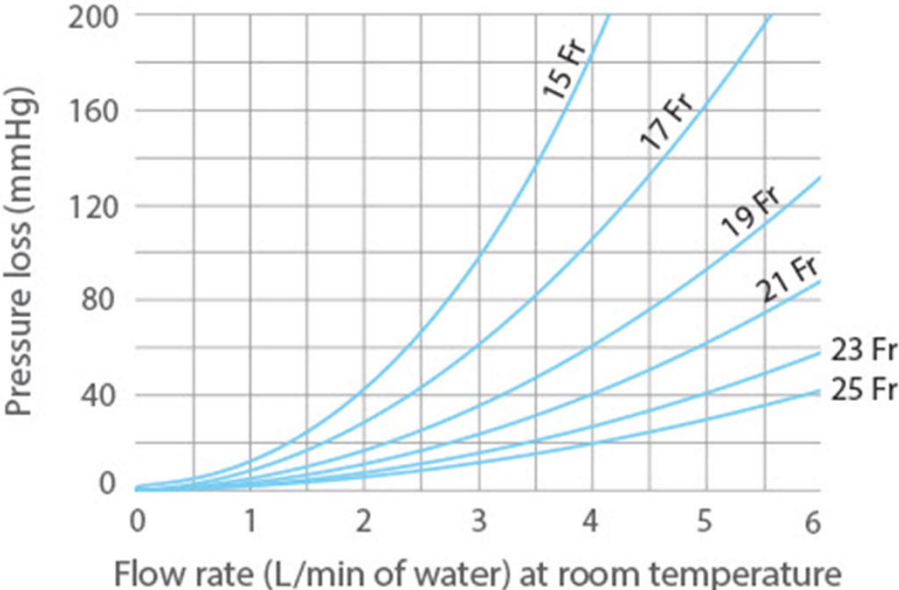

# Lignes de connexion

Connexion des divers éléments de l'ECMO

Unité de mesure : inch ou pouce (25,4 mm)

- 1/2 ( $\approx 12$  mm) (CEC)
- 3/8 ( $\approx 10$  mm) (ECMO +++)
- 1/4 ( $\approx 6,4$  mm) Bonne hémocompatibilité

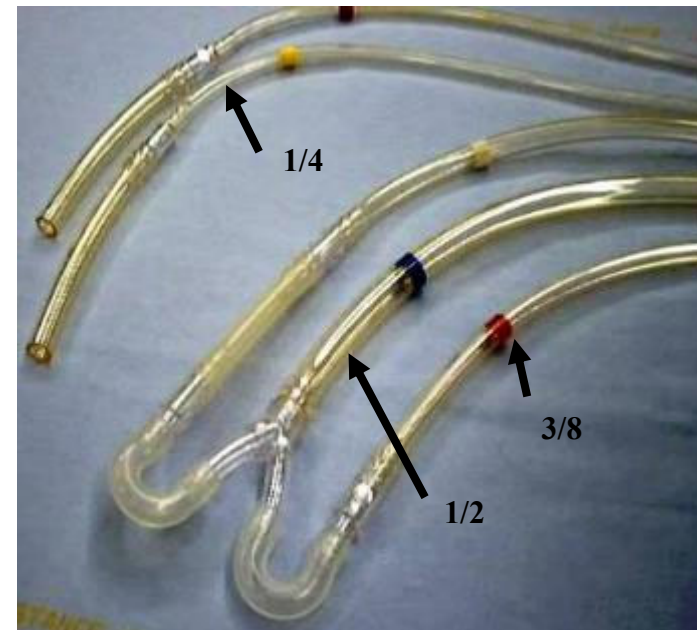

# Surgical access

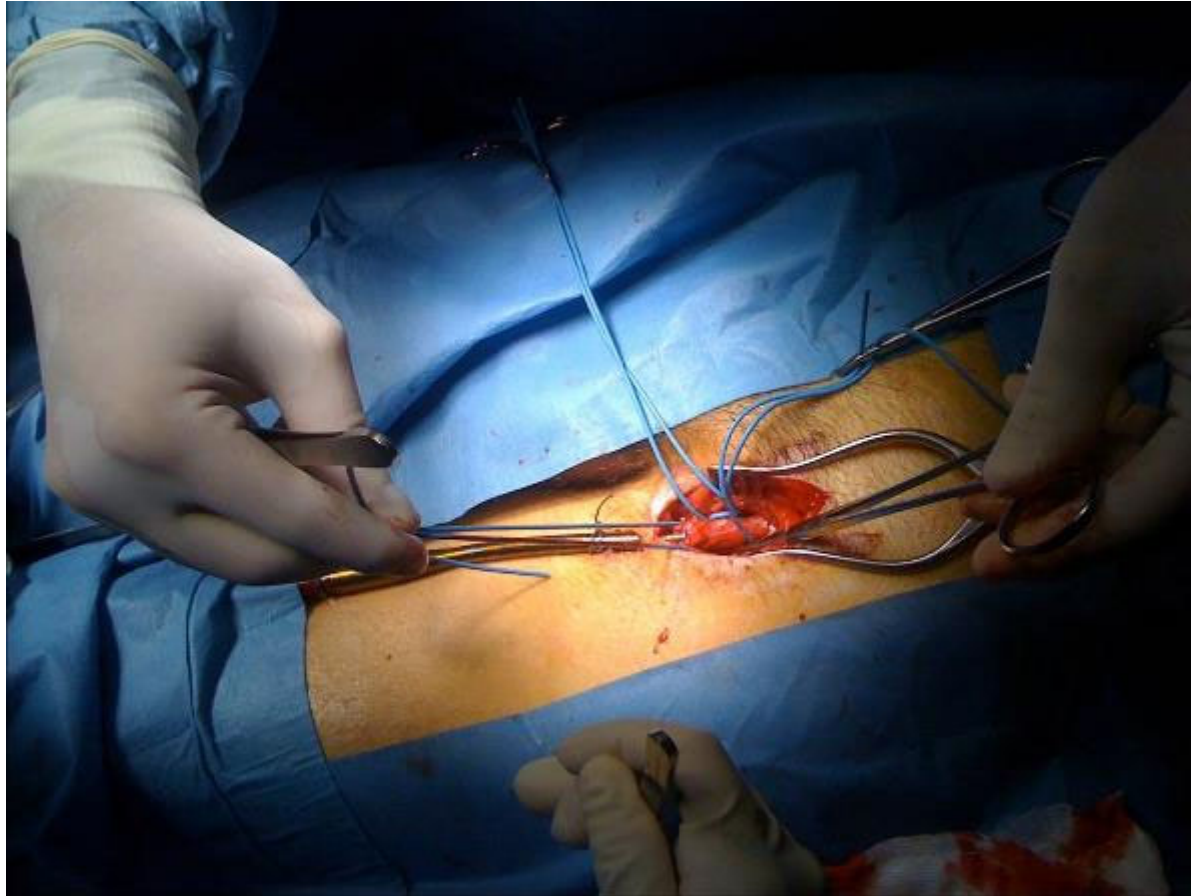

# Percutaneous versus surgical femoro-femoral veno-arterial ECMO: a propensity score matched study

**Table 2 VA-ECMO-related outcomes in the propensity matched population**

	Surgical group n = 266 (%)	Percutaneous group n = 266 (%)	p value
30-Day overall survival	150 (56.3)	170 (63.8)	0.034
Cannulation site infection	74 (27.8)	44 (16.5)	0.001
Infection requiring surgical revision <sup>a</sup>	40 (15.0)	14 (5.3)	< 0.001
Vascular complications at cannulation <sup>b</sup>	7 (2.6)	10 (3.8)	0.663
Limb ischemia	33 (12.4)	23 (8.6)	0.347
Cannula relocation or removal	25 (9.4)	15 (5.6)	0.258
Limb fasciotomy	10 (3.8)	6 (2.3)	0.310
Amputation	2 (0.8)	2 (0.8)	1.000
Vascular complications after cannula removal	9 (3.4)	39 (14.7)	< 0.001
Surgical revision for persistent bleeding early after decannulation	4 (1.5)	25 (9.4)	< 0.001
Surgical revision in the days after decannulation <sup>c</sup>	5 (1.9)	14 (5.3)	0.035
Lower limb sensory-motor deficit	6 (2.3)	7 (2.6)	0.779

Extrémité non radio-opaque (2-3 cm)

**ECLS VA**

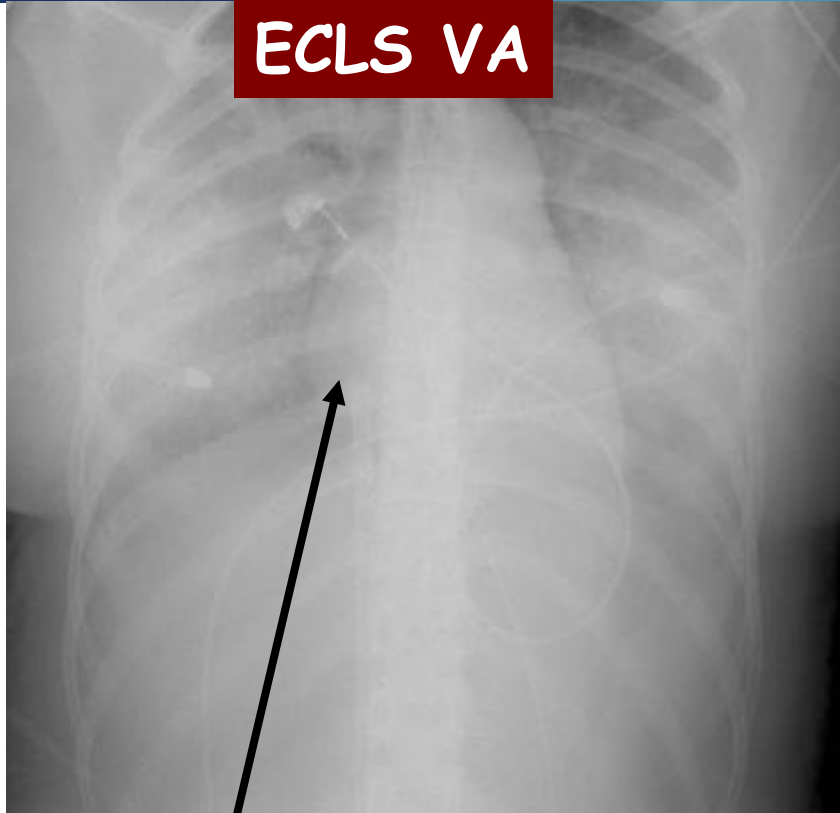

Veine cave inférieure (drainage)

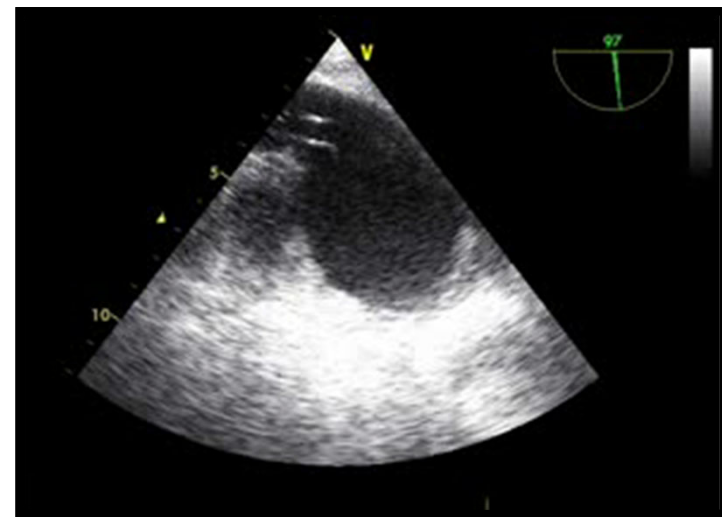
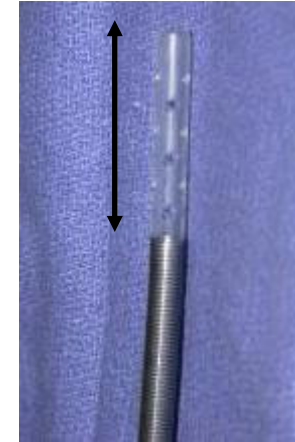

ME bicaval

Mise en place sous ETO ou contrôle rapide!

---

## Peripheral venous-arterial ECLS

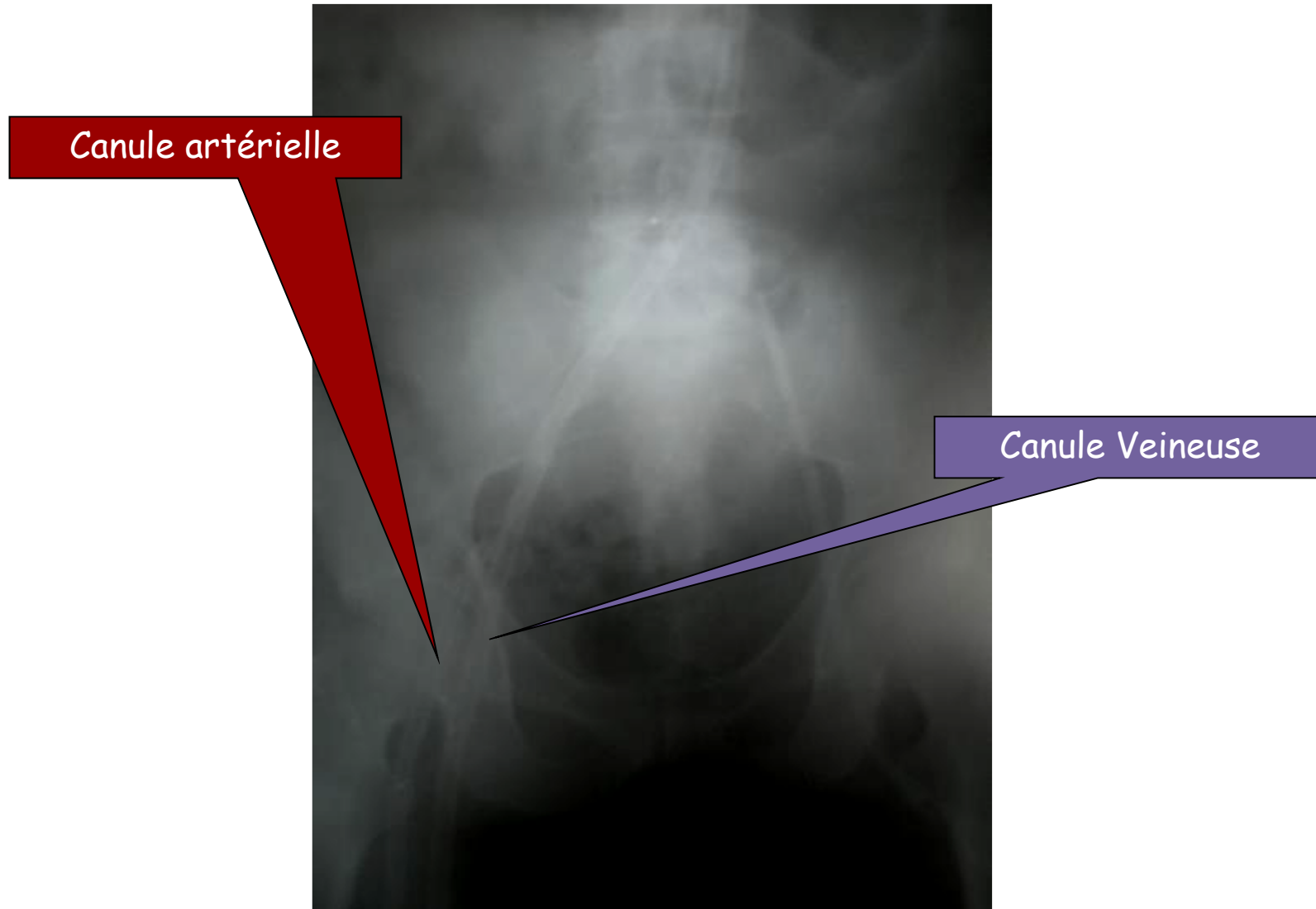



Solidement fixée  
Contrôlée à l'angio  
Fémorale superficielle

Reperfusion line  
(systematically inserted)

Peripheral VA ECLS

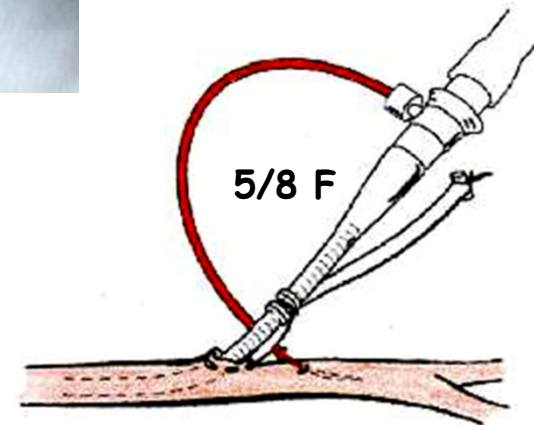

This reperfusion line is alimented by arterial canula (risk of ischemia when ECLS flow is decreased)  
Usefulness of NIRS (STO2) for detecting early lower limb ischemia

Schachner T et al. Eur J Cardiothorac Surg 2008; 34:1253-4

# DÉTECTION ISCHÉMIE MI = CLINIQUE ET NIRS +++



Saturométrie Transcutanée

# ROTATIVE CENTRIFUGAL PUMP

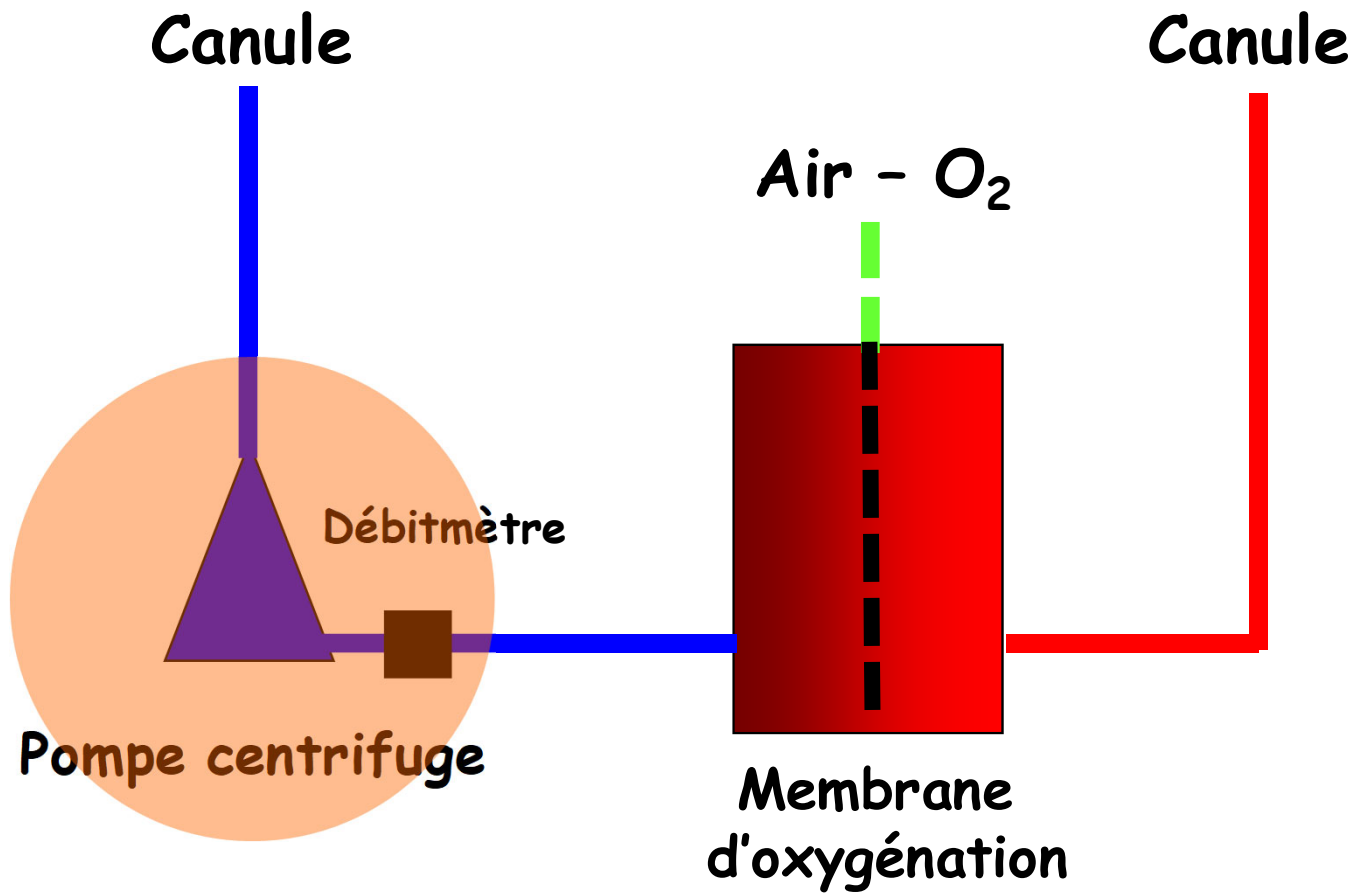

# Magnetically Coupled Pumps

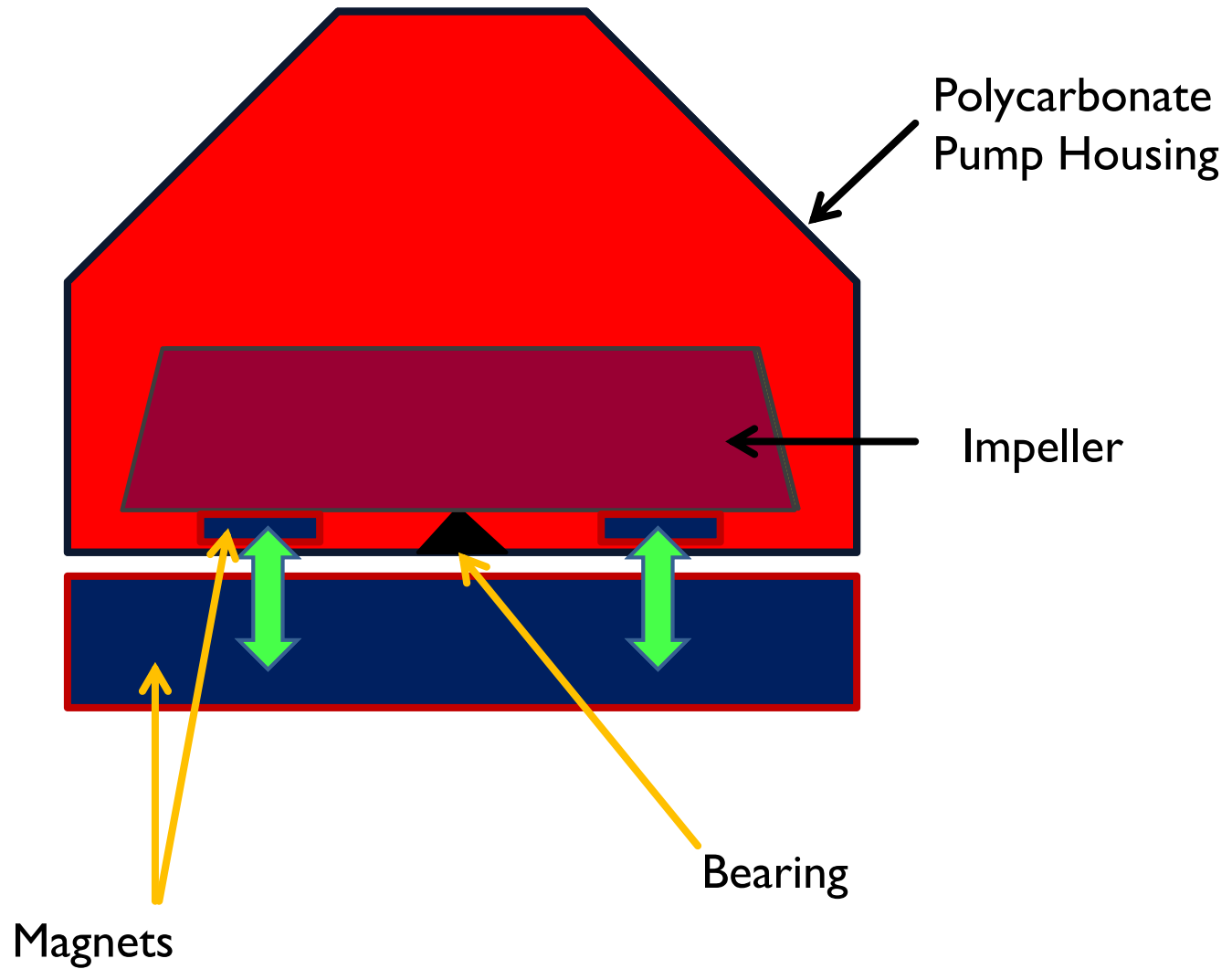

## CENTRIFUGAL ROTATIVE PUMP

- Non-occlusive
- Flow depends:
  - Gradient pressure generated by impeller (speed of rotation)
  - Size of canula, length and diameter of tubing
  - Volemia of patient (pre-load of the pump)
  - Systemic vascular resistances (after-load of the pump)
- Preload and after-load dependence +++
- Measurement of CO is mandatory (electromagnetic or ultrasonic method)
- Backflow phenomenon possible when speed of pump < 1500 TRM **Please clamp the tubing +++**



**Rotaflow, MAQUET 32 ml**



**Biomedicus, Medtronic®  
(cones superposés)**



**Deltastream pump, MEDOS (16 ml)**



**Revolution, Sorin®  
(avec aubes vitesse moindre)**



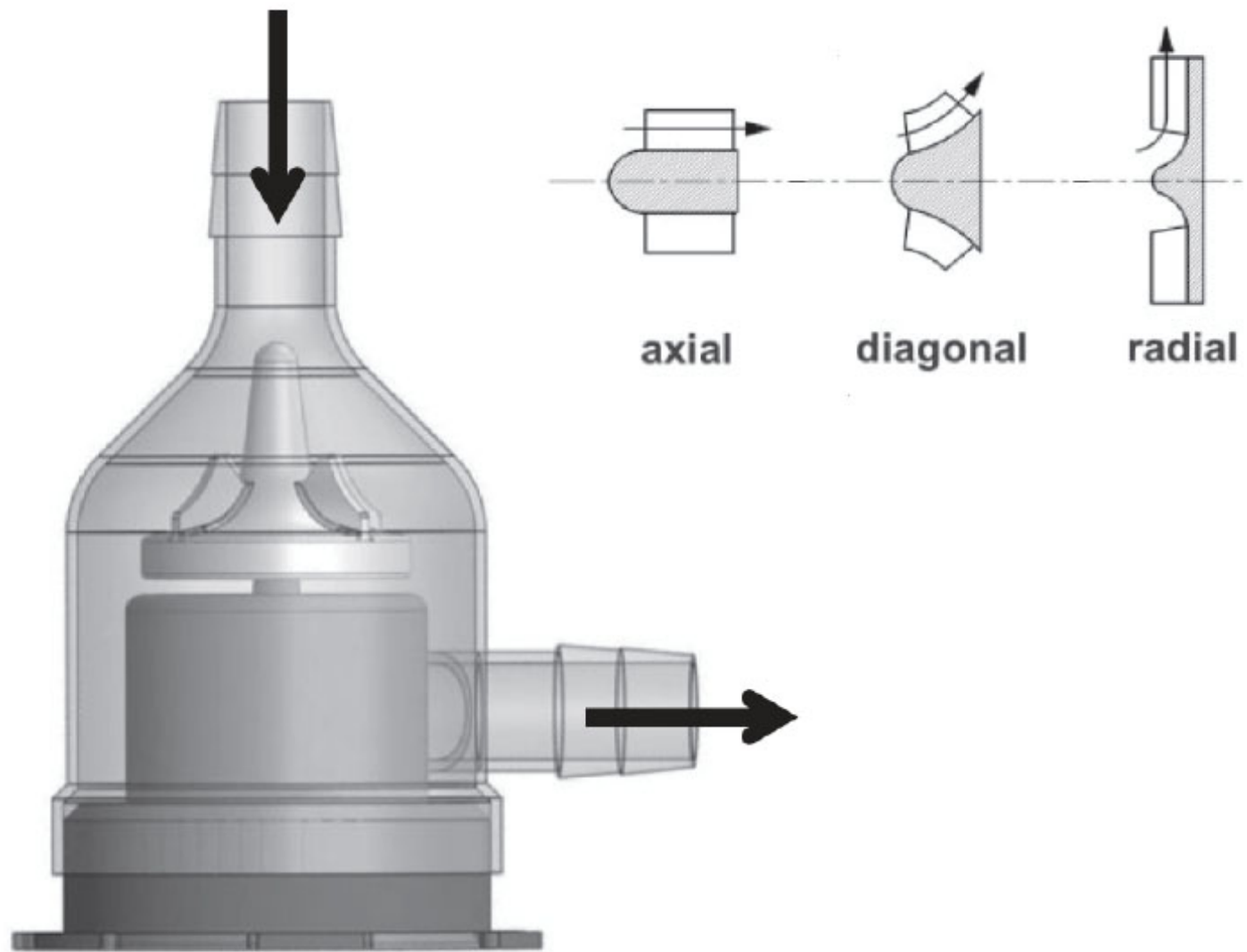



**Biomedicus 550, Medtronic**



Stockert centrifugal pump console



Biomedicus 560, Medtronic



Maquet Cardiopulmonary



Approuvée pour une utilisation de 7 jours, mode pulsatile



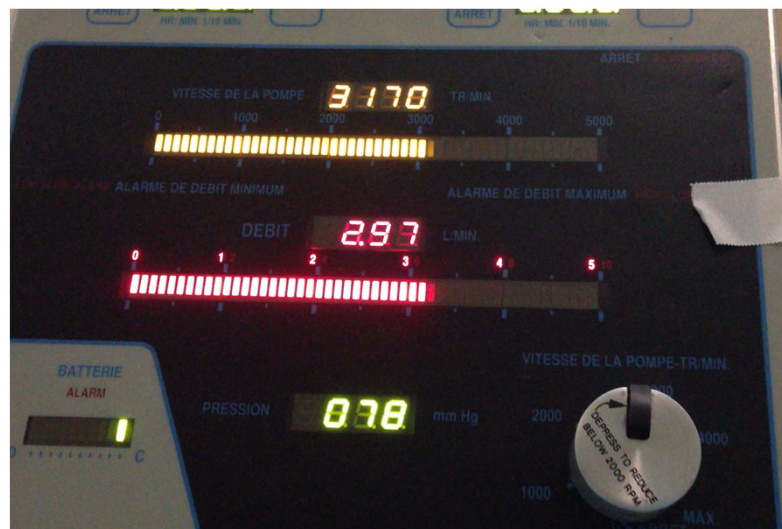
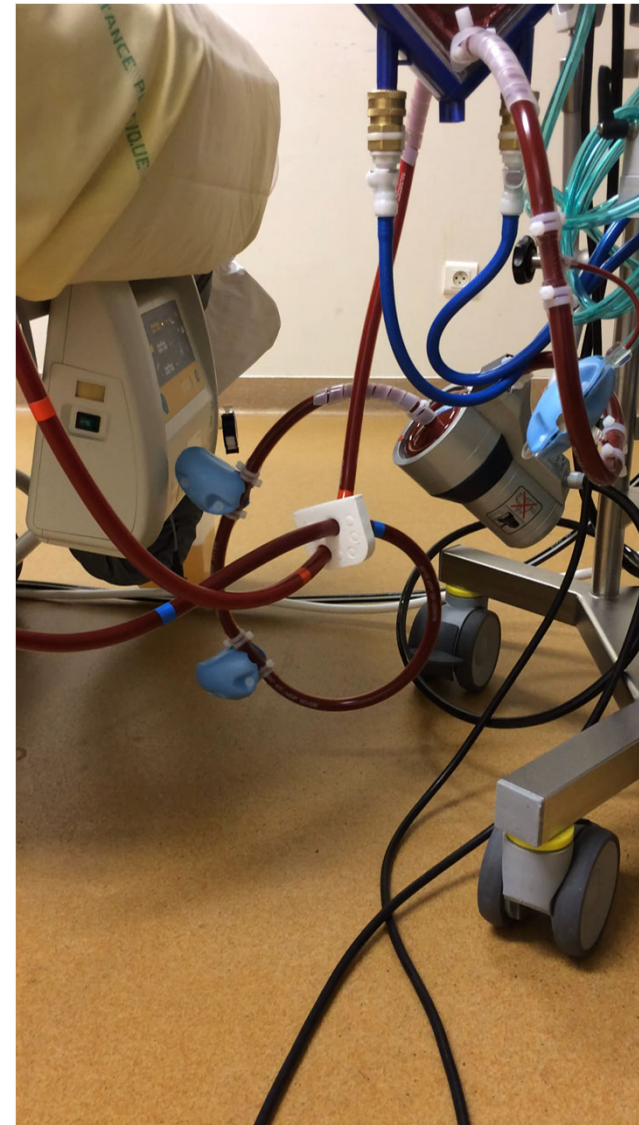
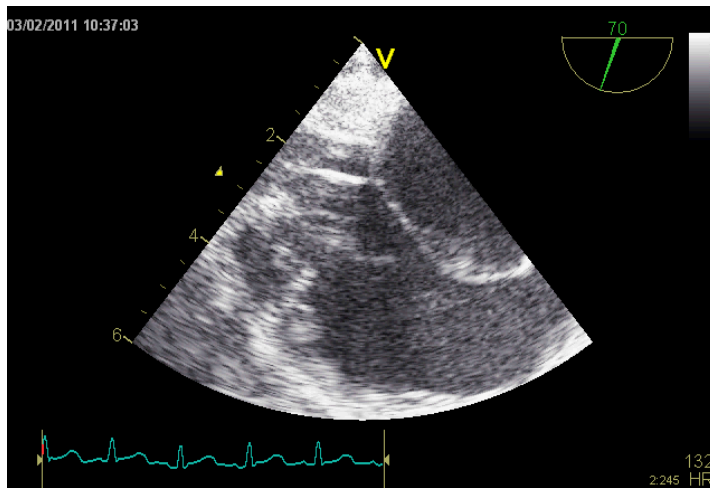

Decrease pump speed (and thus flow), fluid loading if possible or gently pull back canula

# MESURE IMPÉRATIVE DU DÉBIT SANGUIN (EFFET DOPPLER)

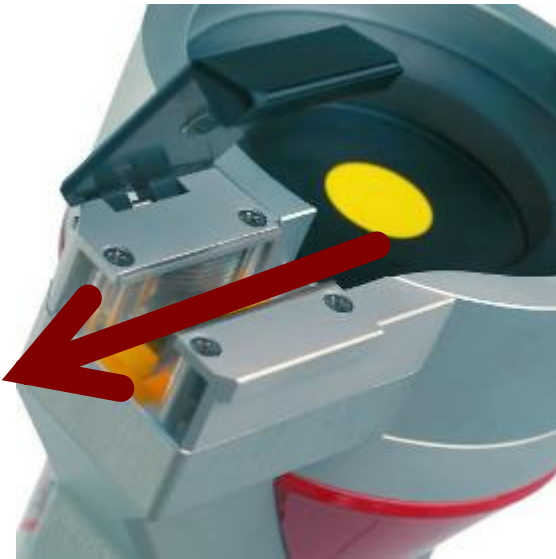

## BACKFLOW (SPEED < 1500 TRM)

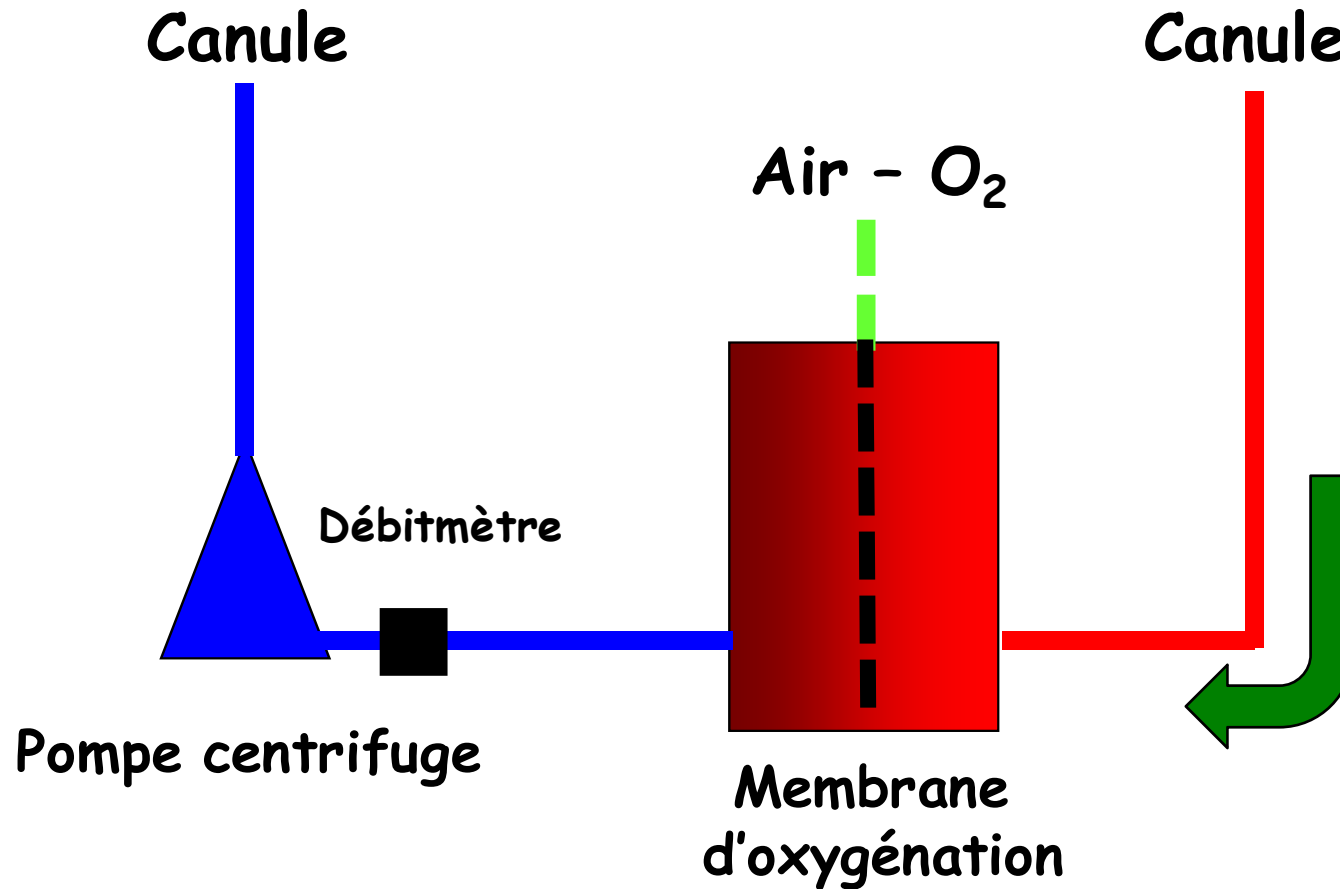

Clamp imperatively arterial line if speed is profoundly decreased +++

# Magnetically levitated pump

## MAGNETIC LEVITATION

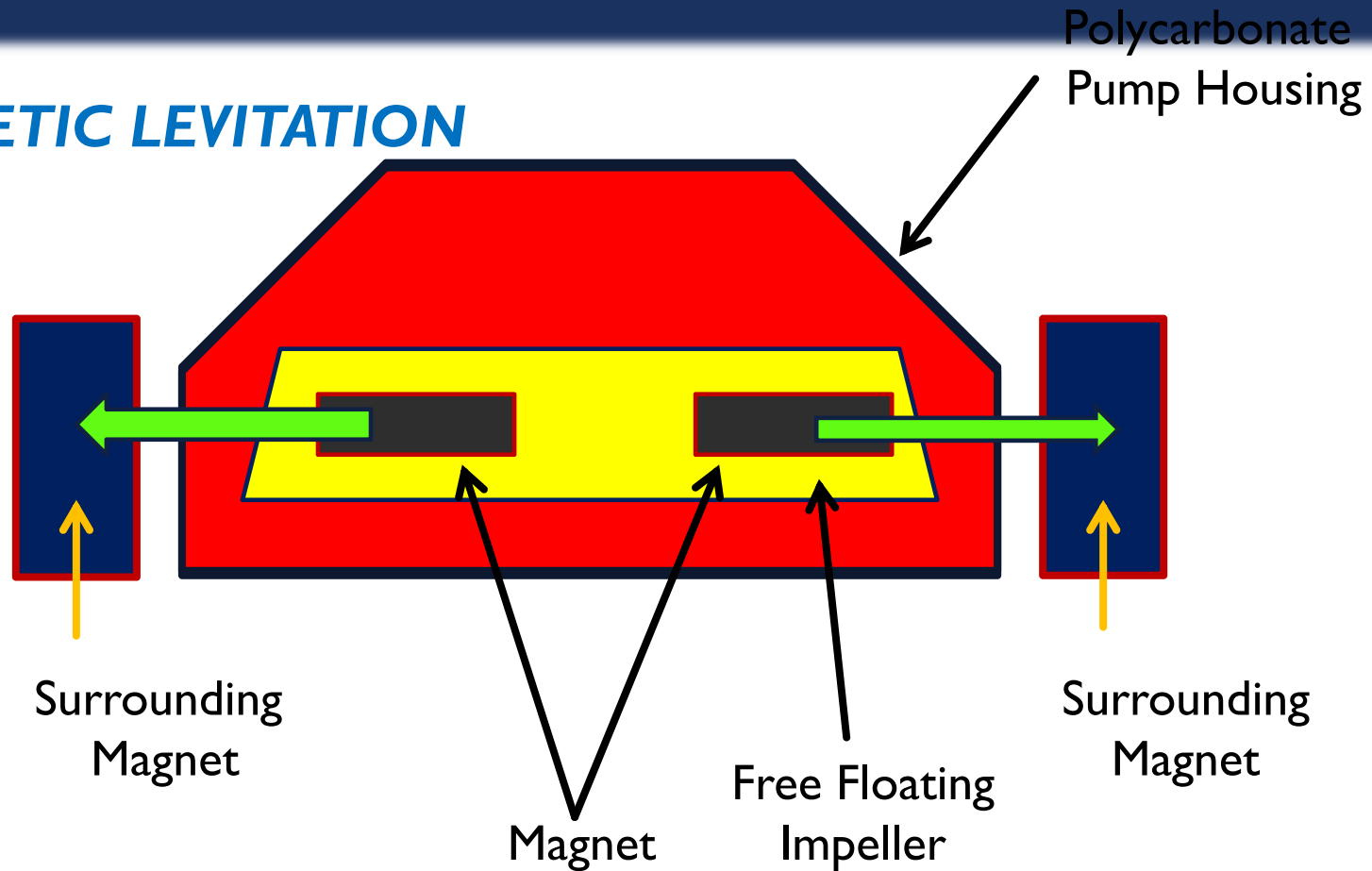

# SYSTEM COMPONENTS – 2<sup>ND</sup> GEN



**Centrifugal pump**



**Motor**



**Console**



# OXYGENATOR MEMBRANE

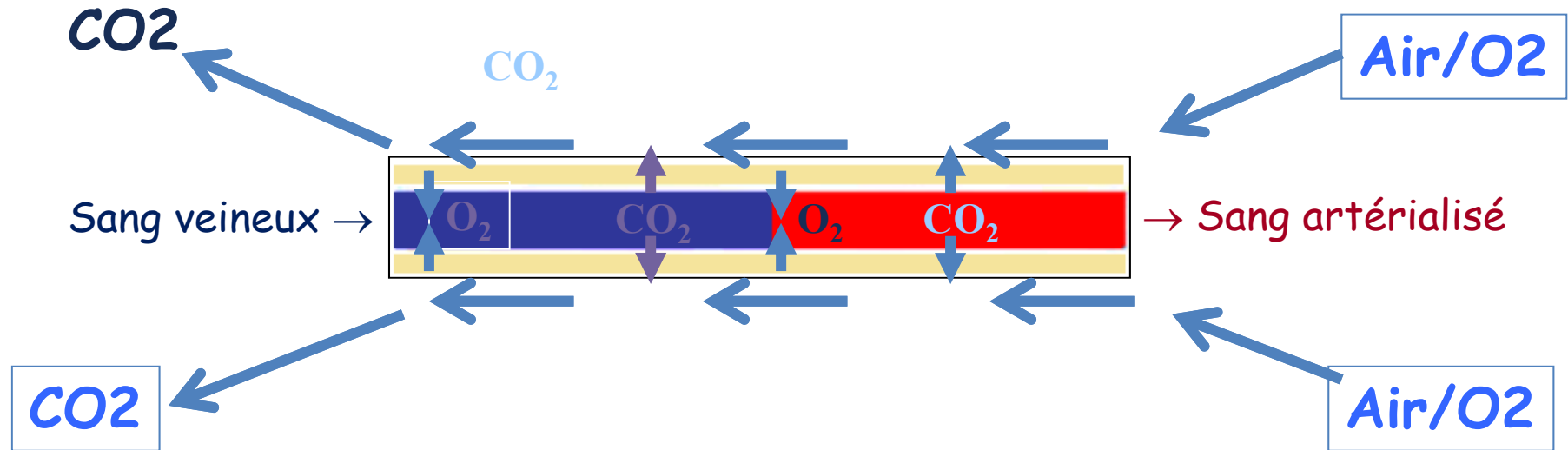



Venous compartment

Arterial compartment

Different color means that membrane works very well (blood gas analysis may be performed)

## ***Micropores Membrane (CEC)***

(Polypropylène)

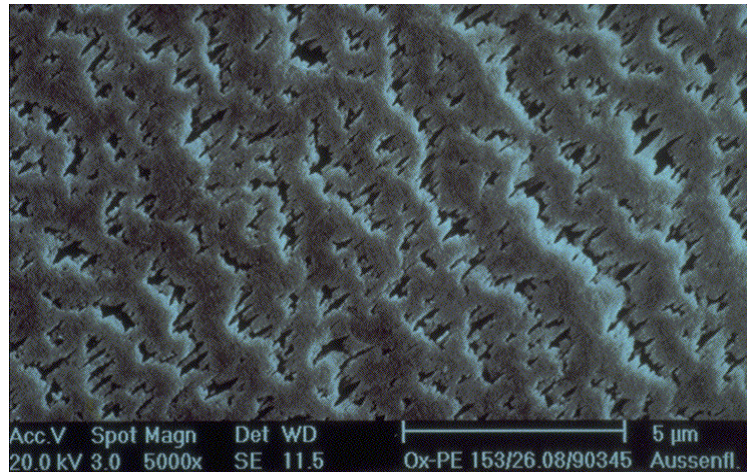

Micropores for gas exchange

## ***Diffusion Membrane (ECMO)***

(Polyméthylpentène)

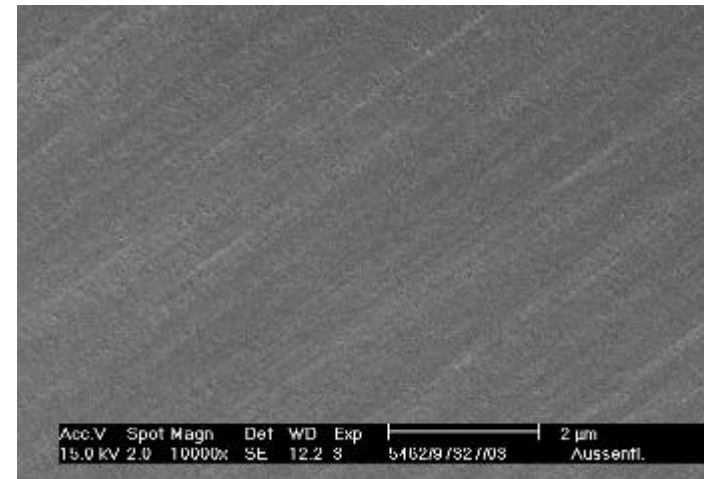

Diffusion of gas through the permeable membrane (human lung)

Better transfert

Impermeable for plasma

Possible coating

No plasma leakage

Duration of use (label CE 14 days)

## Surface coating



**Membrane surface without SAFELINE treatment:** Uncoated membrane with depositions potentially leading to high pressure drop phenomena.

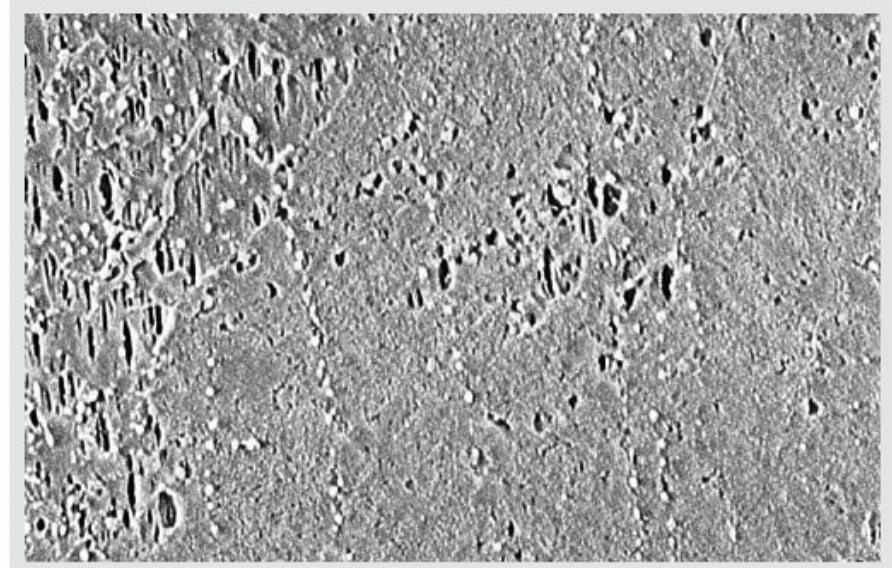

**QUADROX membrane surface with SAFELINE treatment:** The advantage of the SAFELINE treatment under the electron microscope: significant reduction in surface deposition on the QUADROX membrane. The typical transmembrane pressure increase is minimized consistently.

# Membrane's characteristics

### Oxygen Transfer

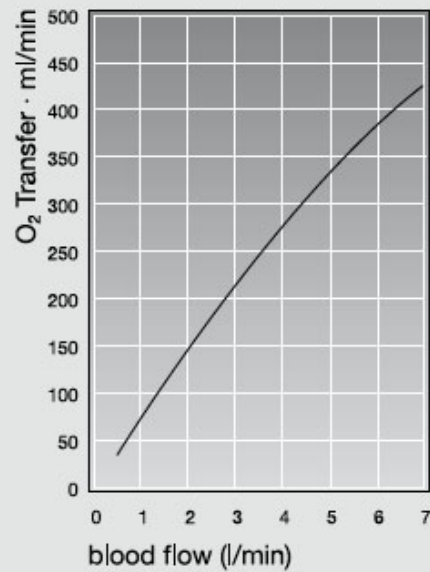

### Carbon Dioxide Transfer

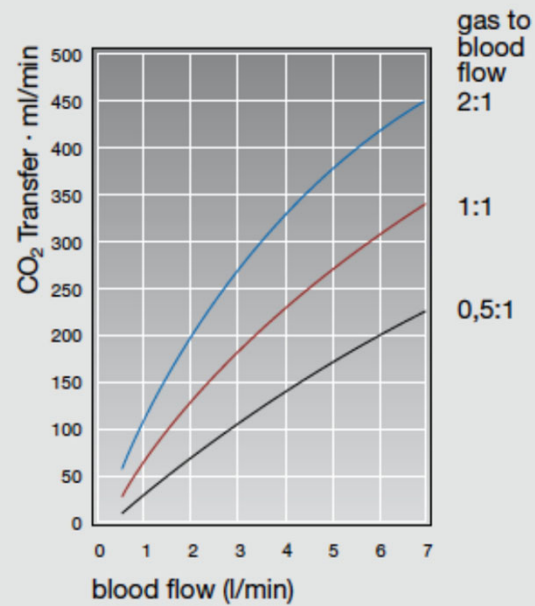

### Pressure Drop (Perte de charge)

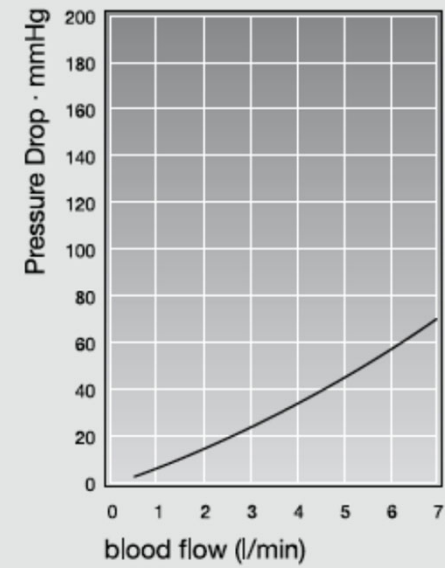

# Bloc thermique



# MONITORAGE HÉMODYNAMIQUE I

- Pression artérielle moyenne
  - KT radial droit +++ (sang cœur natif)
  - Oxygénation cérébral et myocardique
  - PAM 60-70 mmHg (post-charge dépendance)
  - Aspect linéaire = absence de récupération
- Pression veineuse centrale (décharge cavités droites)

Artère non pulsée



Swan-Ganz

# Monitoring Hémodynamique II

- **Cathéter de Swan-Ganz**
  - Saturation veineuse mêlée O<sub>2</sub> (SvO<sub>2</sub>)
  - Index cardiaque (appréciation de la qualité de décharge cavités droites)
  - PAP = maintien d'une pression diastolique minimale (flux intra vasculaire)
  - Evaluation de PAPO (PTDVG) risque d'OAP (PAPO < 18 mmHg)
  - Phase de sevrage
- **Echographie (quotidienne ETO > ETT)**
  - Prudence traumatisme induit ++++ (ETT)
  - Positionnement canules veineuse et artérielle (si centrale)
  - Décharge cavités Dte et Gche
  - Evaluation pressions de remplissage
  - Evaluation de la fonction systolique (FE, Tei index, Strain rate,...)
  - Recherche d'un épanchement péricardique
  - Thrombus intra-cavitaire
  - Valvulopathie (IM, IA)
  - Aspect aorte descendante

# MINIMAL BLOOD FLOW TO MEET THE METABOLIC DEMAND

## $DO_2/VO_2$

Mixed venous oxygen saturation (SvO<sub>2</sub>)

Parameter of balance between oxygen delivery (DO<sub>2</sub>) and demand (VO<sub>2</sub>)

Increased oxygen extraction (O<sub>2</sub>ER)

**Goal therapy 70 ± 5 %**

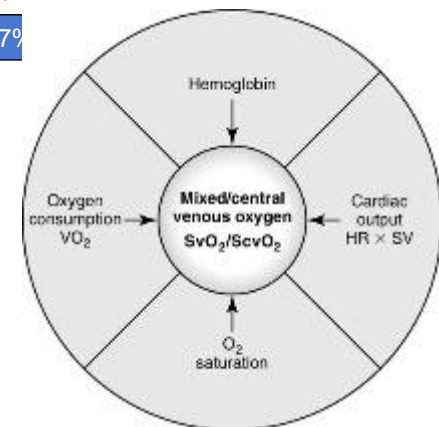
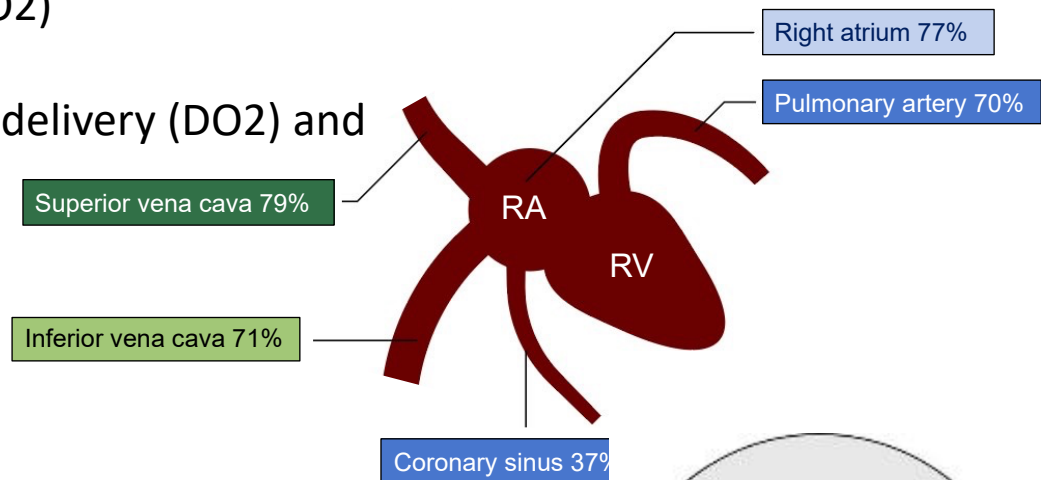

$$O_2ER = \frac{SaO_2 - SvO_2}{SaO_2} = 1 - SvO_2$$

Adapted from Reinhart K 1988

# CIRCUIT D' ECLS

- Perfusionniste (/ 24 à 48h) et personnel de réanimation (MD et IDE)
- Aspect des canules et lignes
  - Caillots, plicature, efficacité du sertissage
  - Ligne de reperfusion +++
  - Aspect des orifices
  - Battement canule veineuse (mauvais drainage)
- Membrane et pompe
  - Recherche de caillots (discuter le changement)
  - Purge circuit gaz frais (condensation)
- Console
  - Meilleur débit avec le moindre de TRM
- Changement de circuit si:
  - Caillots,
  - hémolyse importante,
  - Défaut oxygénation P/F < 150-200 mmHg,
  - Systématique (> 14 j)

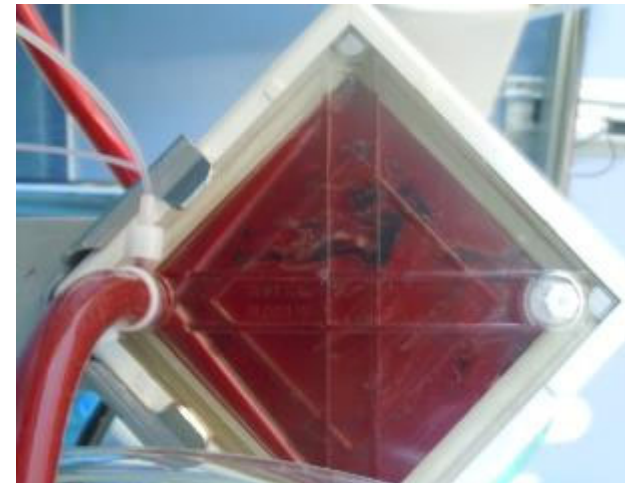

# Monitoring pressions pré- et post-filtre



## Intérêts:

- Suspicion thrombose de filtre si gradient augmente
- Signes évocateurs récupération VG (oscillations pré-filtre)
- Valeurs max 300 mmHg

Faible corrélation ACT avec la dose HNF perfusée

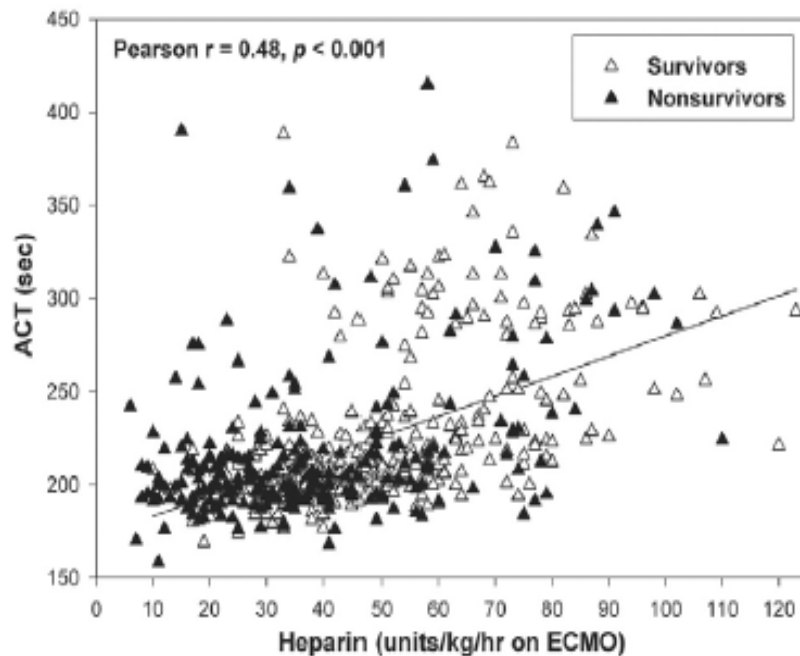

Ann Thorac Surg 2007 83

L'activité antiXa est mieux corrélée à la dose

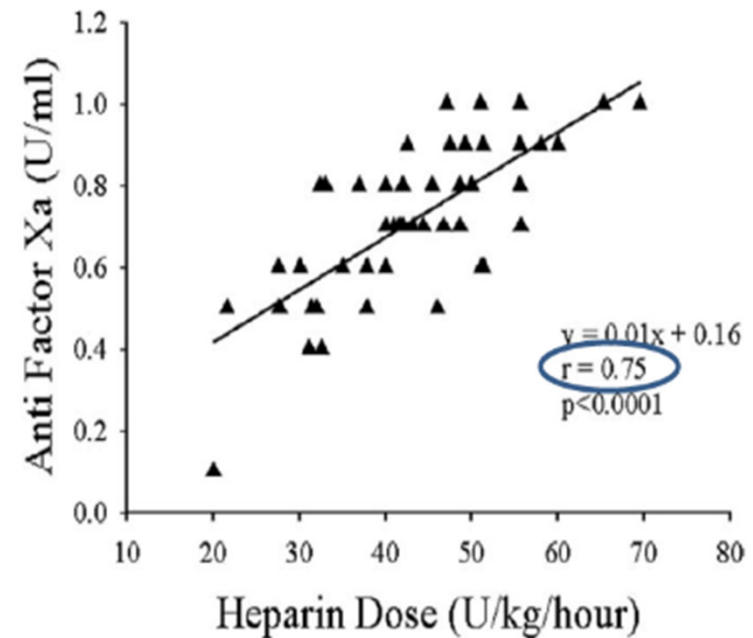

Nankervis CA et al. ASIAO Journal 2007

**Objectif anti-Xa entre 0,2-0,4 UI/ml**

# Rescue procedure



Les devises Shadok



IL VAUT MIEUX POMPER MÊME S'IL NE SE PASSE RIEN QUE RISQUER QU'IL SE PASSE QUELQUE CHOSE DE PIÈRE EN NE POMPANT PAS.



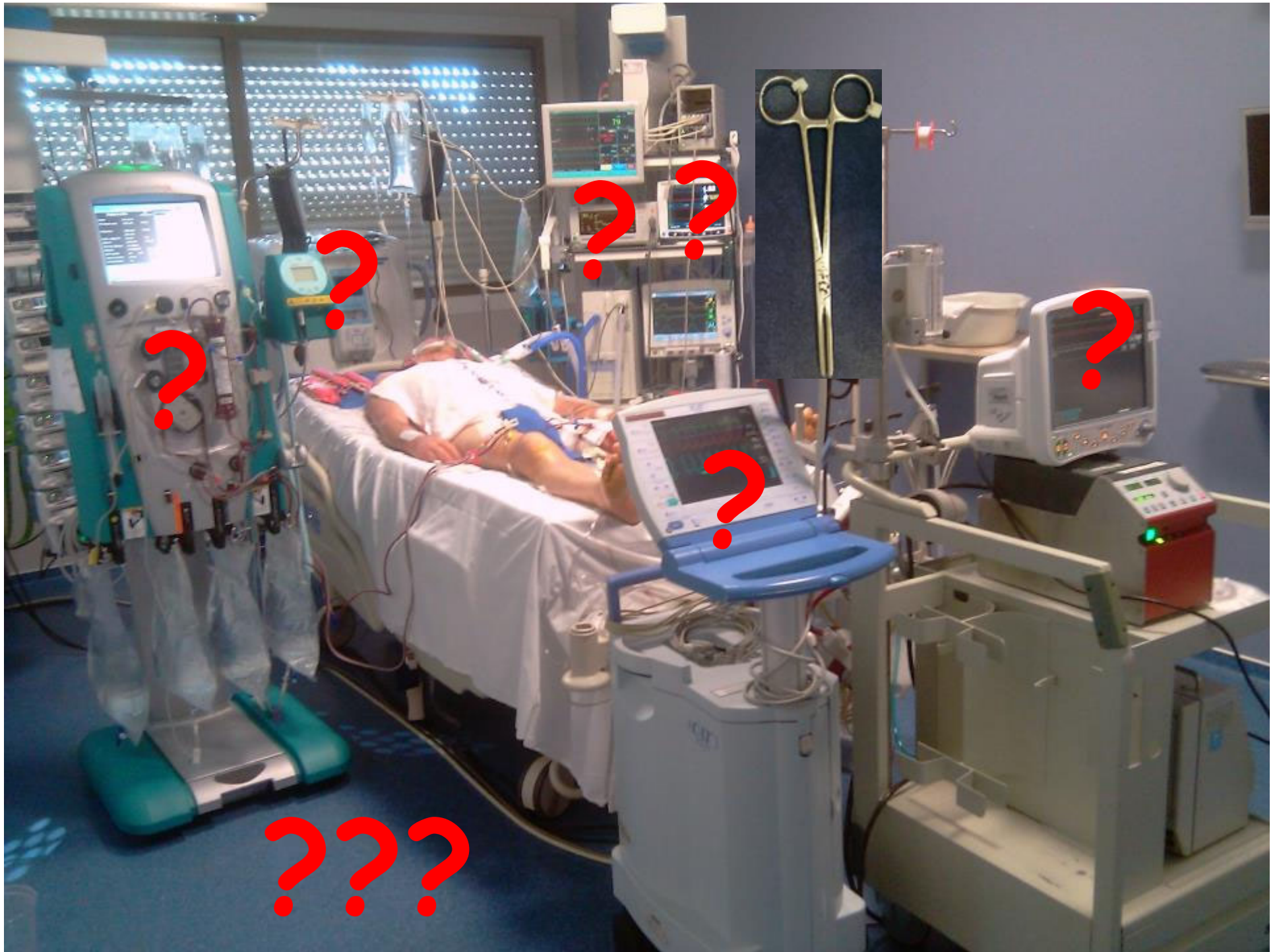

# INTERACTION BETWEEN PERIPHERAL VENO-ARTERIAL ECLS AND NATIVE FAILING HEART

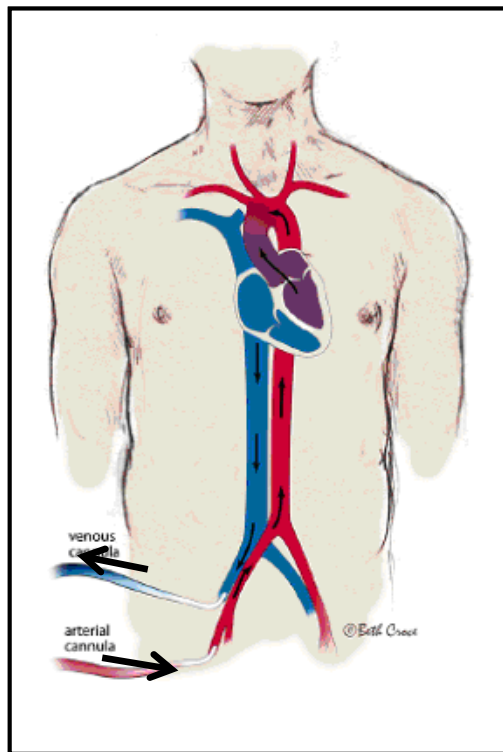

**Retrograde aortic flow in total competition with native stream**

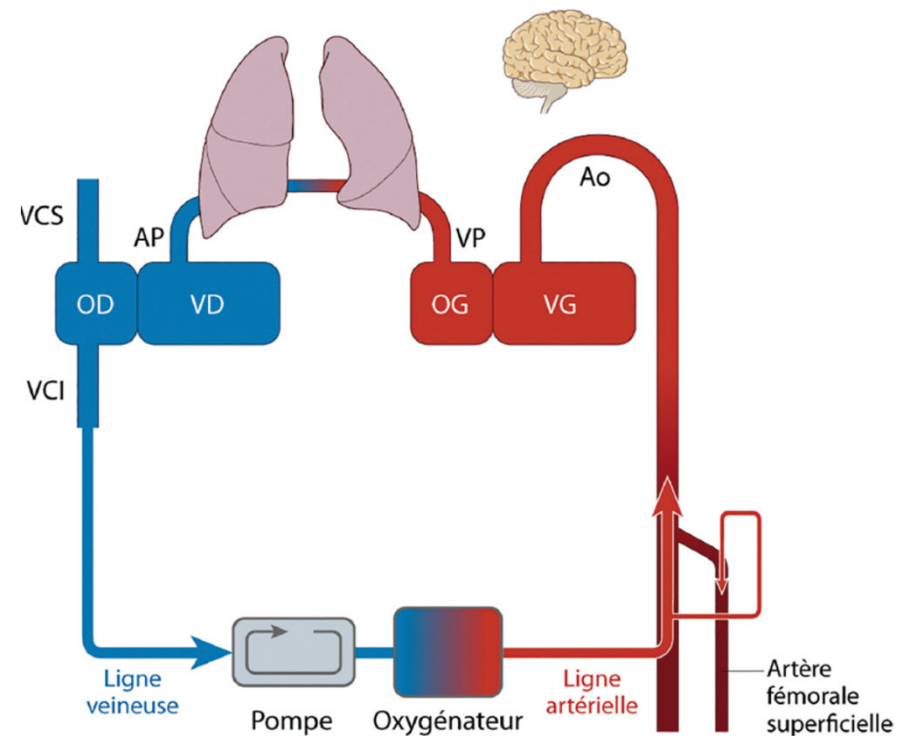

# Haemodynamic Interaction between ECLS and native heart

## Increase in LV afterload induced by peripheral VA-ECMO

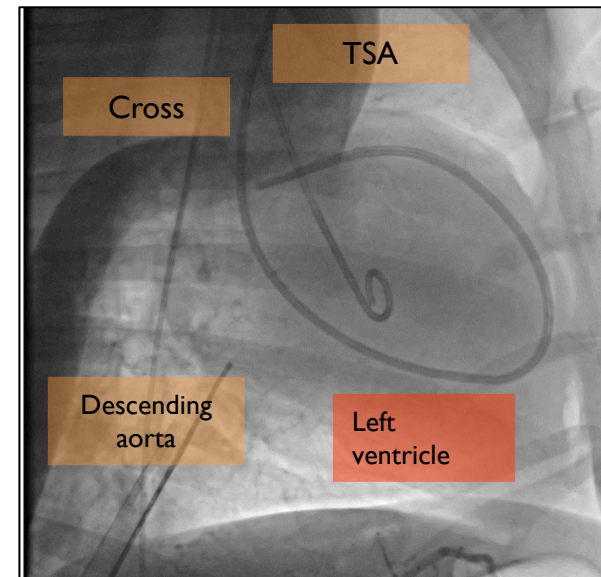
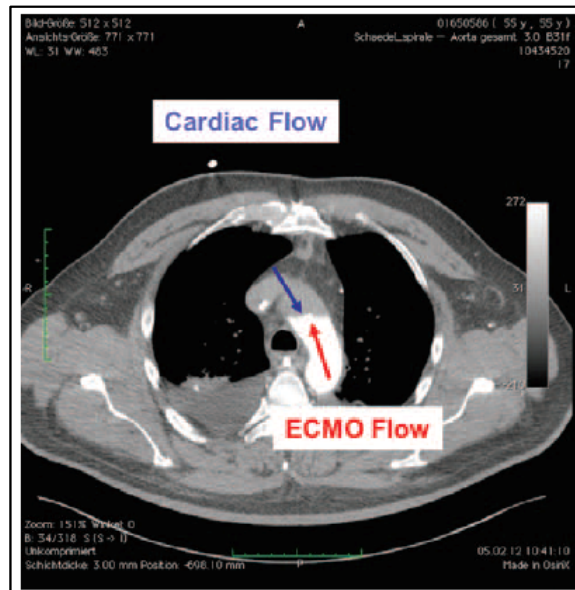
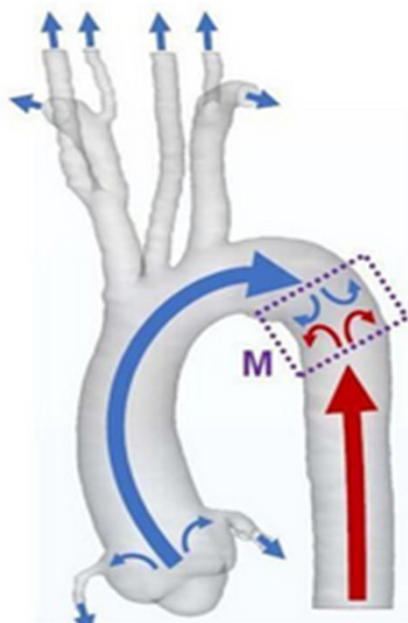

Personal data  
(unpublished)

# Pressure-volume area, mechanical work of LV and $MvO_2$

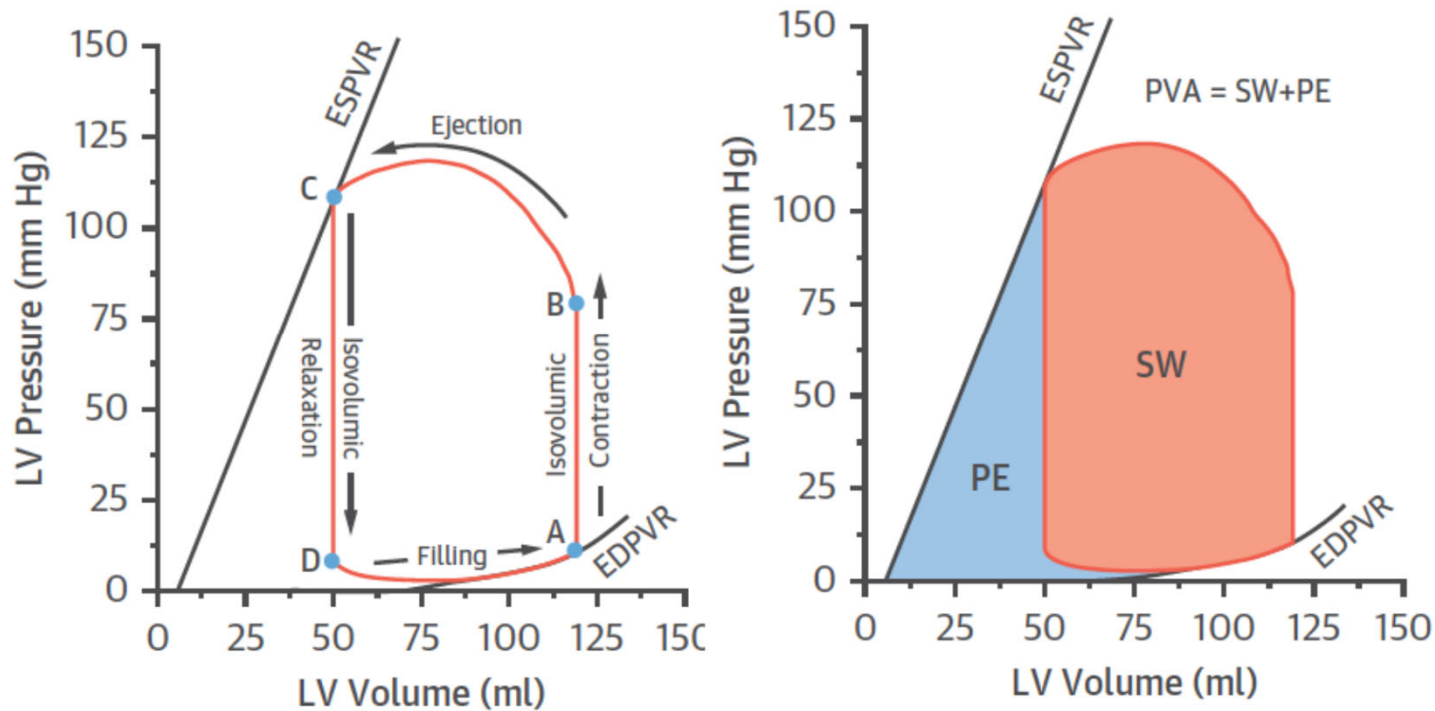

The PVA represents the total mechanical work of LV and may be assessed as the sum of Potential Energy (PE) and stroke work (SW). A relationship exists between PVA and  $MvO_2$

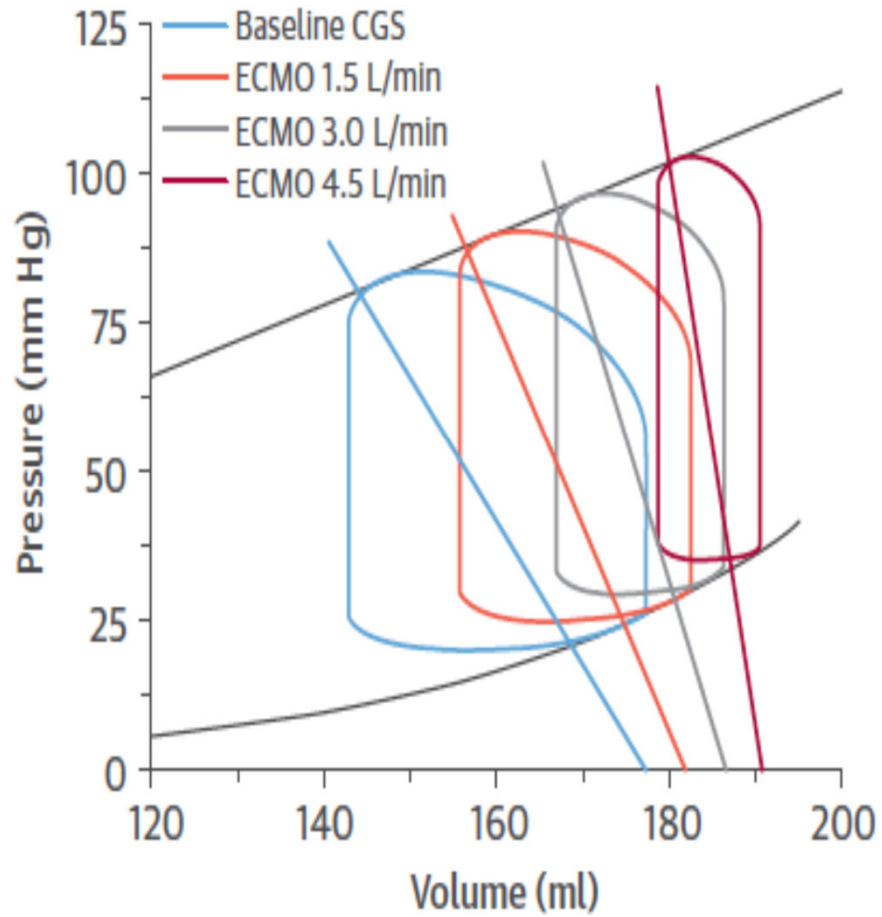

Burkhoff et al. JACC 2015; 66:2663-74

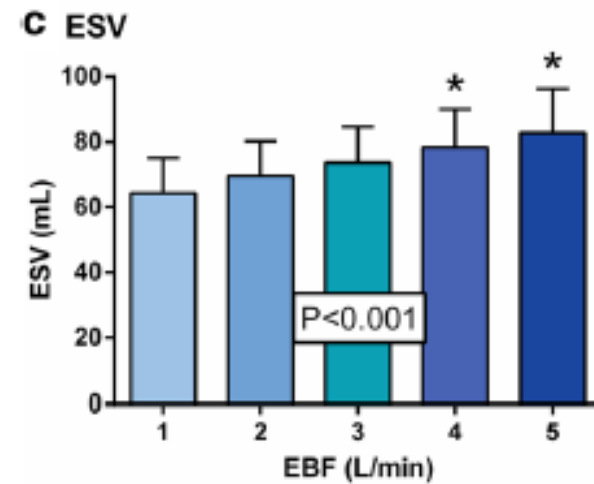
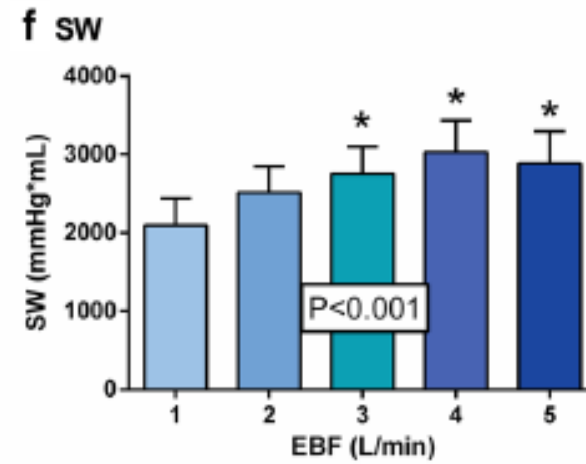

Ostadal.P et al, J Transl Med 2016

## Left Ventricular Mechanical Support with Impella Provides More Ventricular Unloading in Heart Failure Than Extracorporeal Membrane Oxygenation

Basic research in dogs

Haemodynamic monitoring (AP, Swan-Ganz catheter, Millar)

Cardiogenic shock after MI by coronary banding

Peripheral ECLS (10 Fr AF/28 Fr OD)

Total myocardial work  
(PV curve under ECLS)

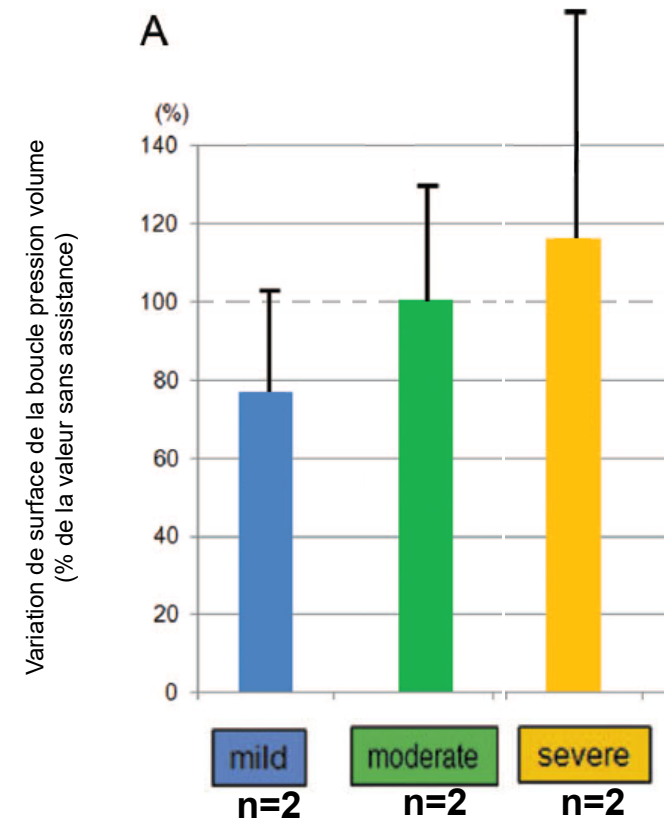
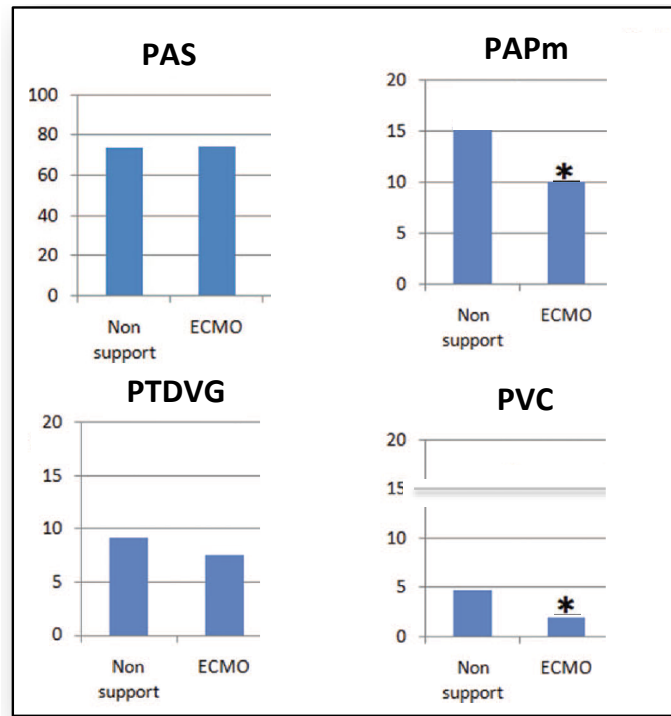

Myocardial ischemia model by aortic clamping (30 min) and reperfusion (30 min) under CPB in sheep (n=14)

LV cavity pressure monitoring (Millar catheter)

ECLS was then instituted with increasing flow (from 20 to 100 ml.kg<sup>-1</sup>.min<sup>-1</sup>)

LV circumferential stress (Systolic Stress index=SSI) correlated to myocardial oxygen consumption

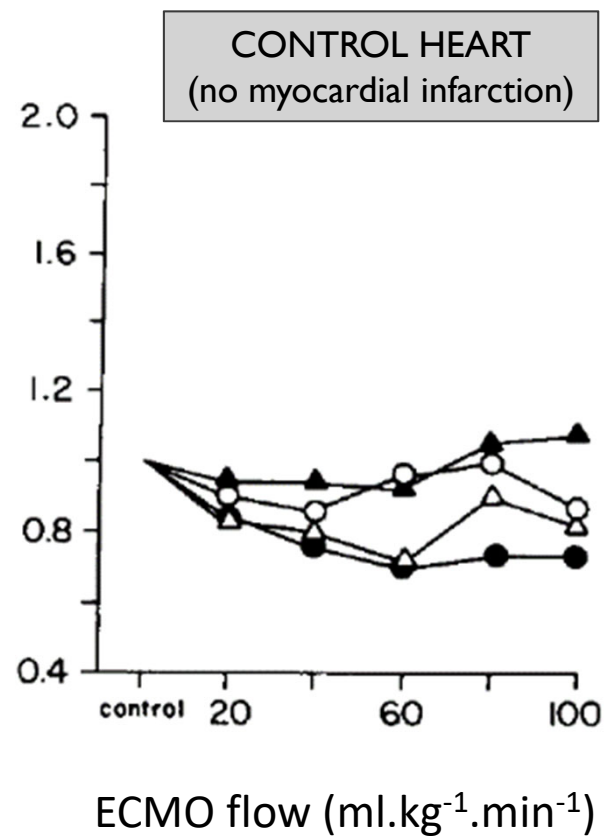

△ SSI  
▲ LVP  
○ ESV  
● EDV

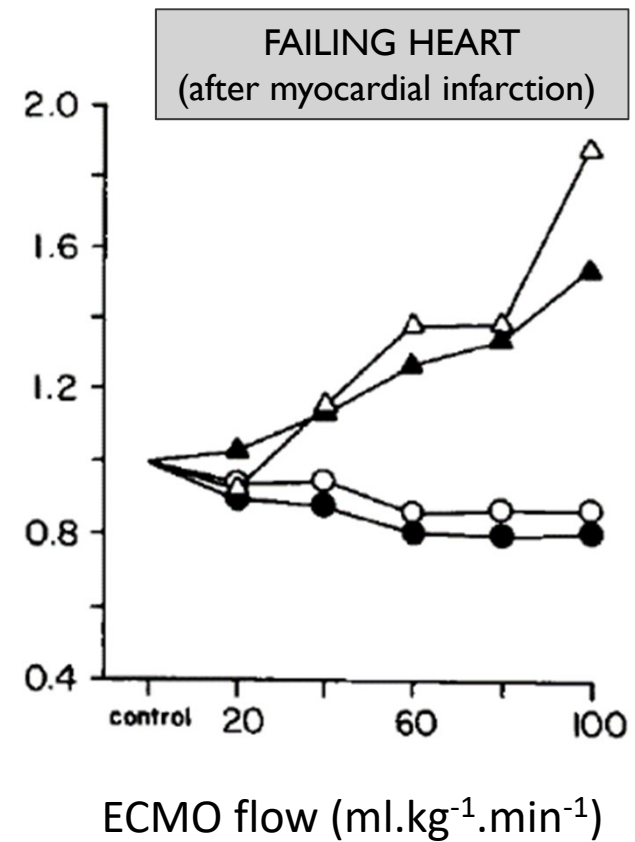

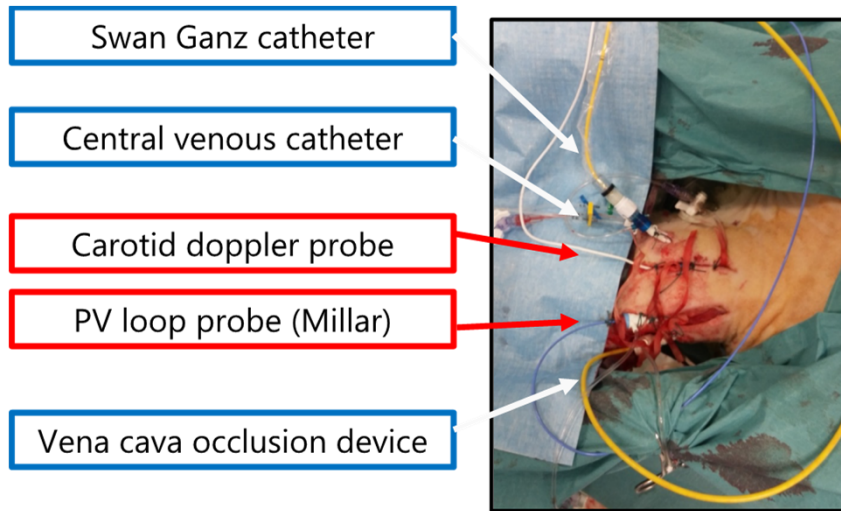

OPEN

## A total closed chest sheep model of cardiogenic shock by percutaneous intracoronary ethanol injection

Mario Rienzo<sup>1,2,9</sup>, Julien Imbault<sup>1,2,9</sup>, Younes El Boustani<sup>1,2</sup>, Antoine Beurton<sup>1,2</sup>, Carolina Carlos Sampedrano<sup>3,4</sup>, Philippe Pasdois<sup>3,4</sup>, Mathieu Pernot<sup>1,5</sup>, Olivier Bernus<sup>3,4</sup>, Michel Haissaguerre<sup>3,4,6</sup>, Thierry Couffinhal<sup>1,7</sup> & Alexandre Ouattara<sup>1,2,8</sup>

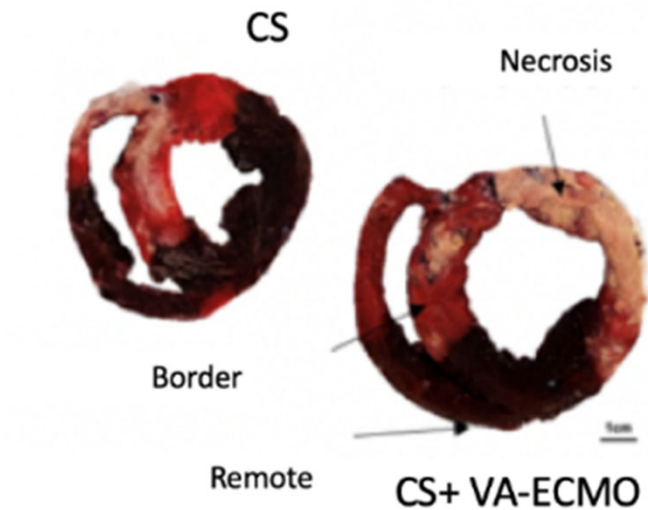

A

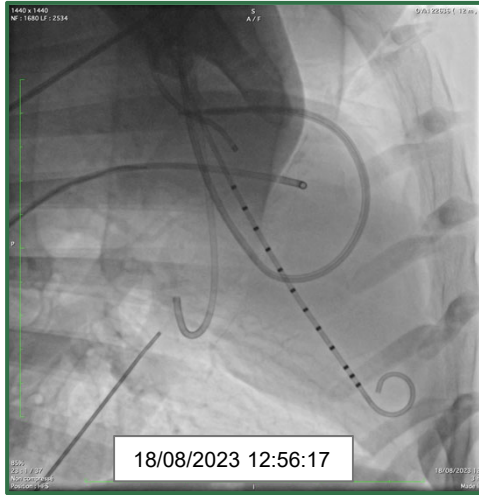

Proximal occlusion of LAD coronary artery



Left ventricular anterior wall akinesia

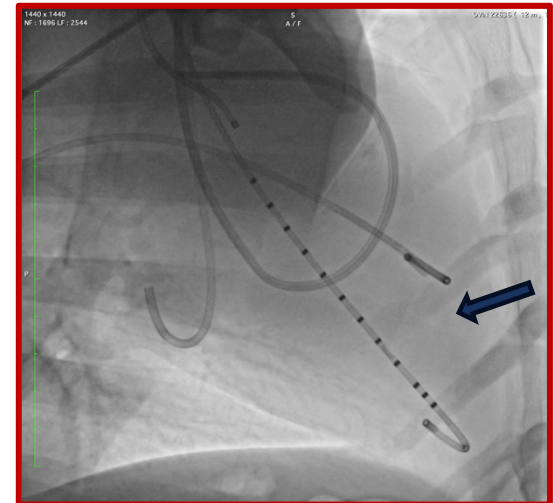
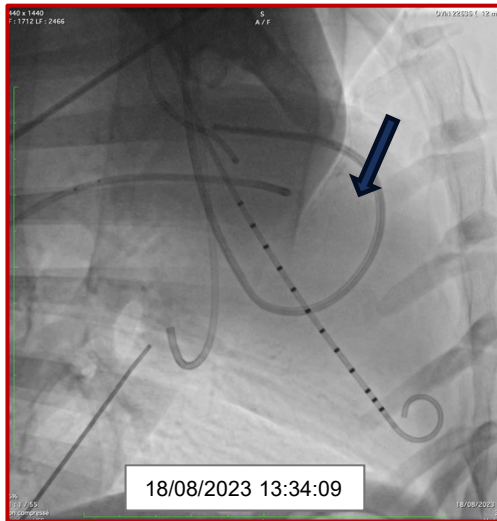

## Systemic Hemodynamics, Cardiac Mechanics, and Signaling Pathways Induced by Extracorporeal Membrane Oxygenation in a Cardiogenic Shock Model

ANTOINE BEURTON,<sup>\*†</sup> MAXIME MICHOT,<sup>†</sup> FRANÇOIS-XAVIER HÉRION,<sup>\*†</sup> MARIO RIENZO,<sup>‡</sup> CLAIRE ODDOS,<sup>\*</sup> THIERRY COUFFINHAL,<sup>†</sup> JULIEN IMBAULT,<sup>\*†</sup> AND ALEXANDRE OUATTARA<sup>①\*</sup><sup>†</sup>

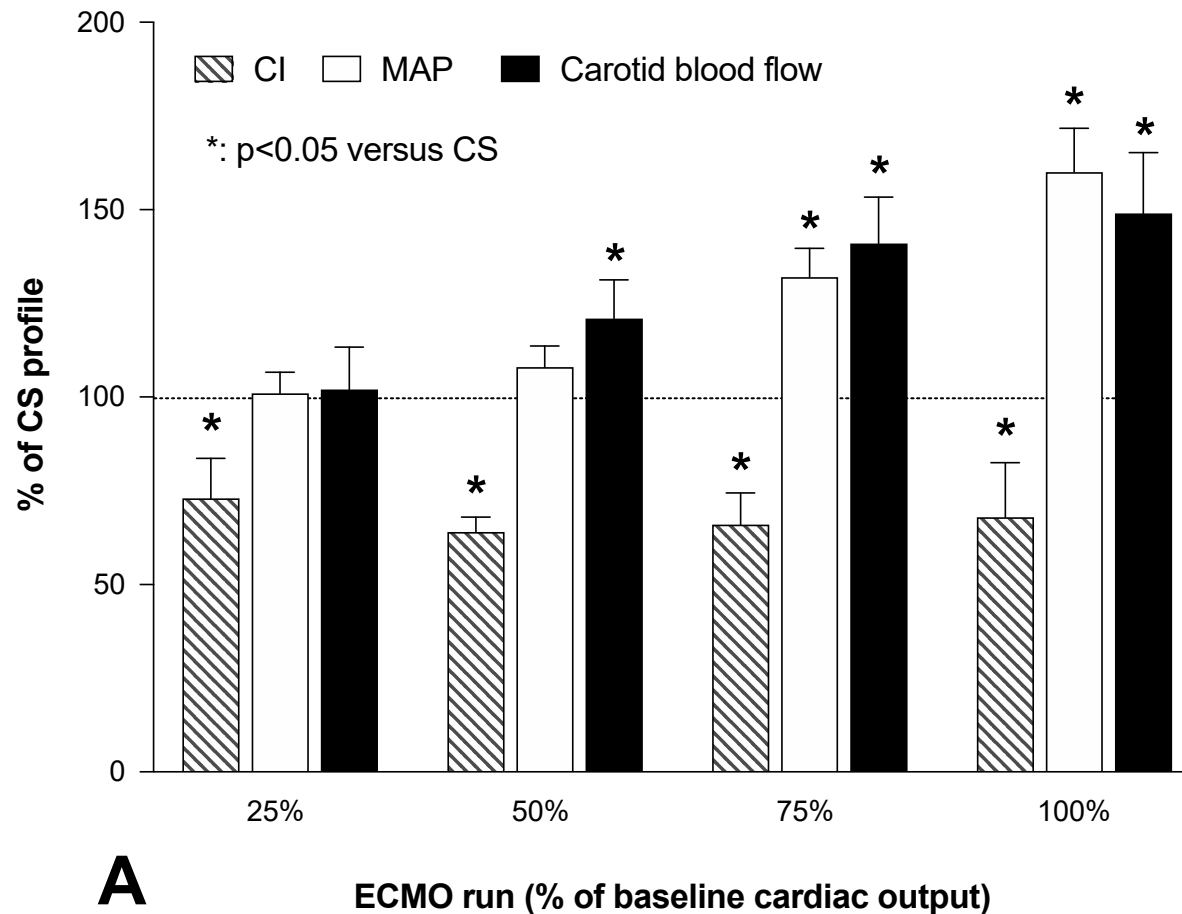

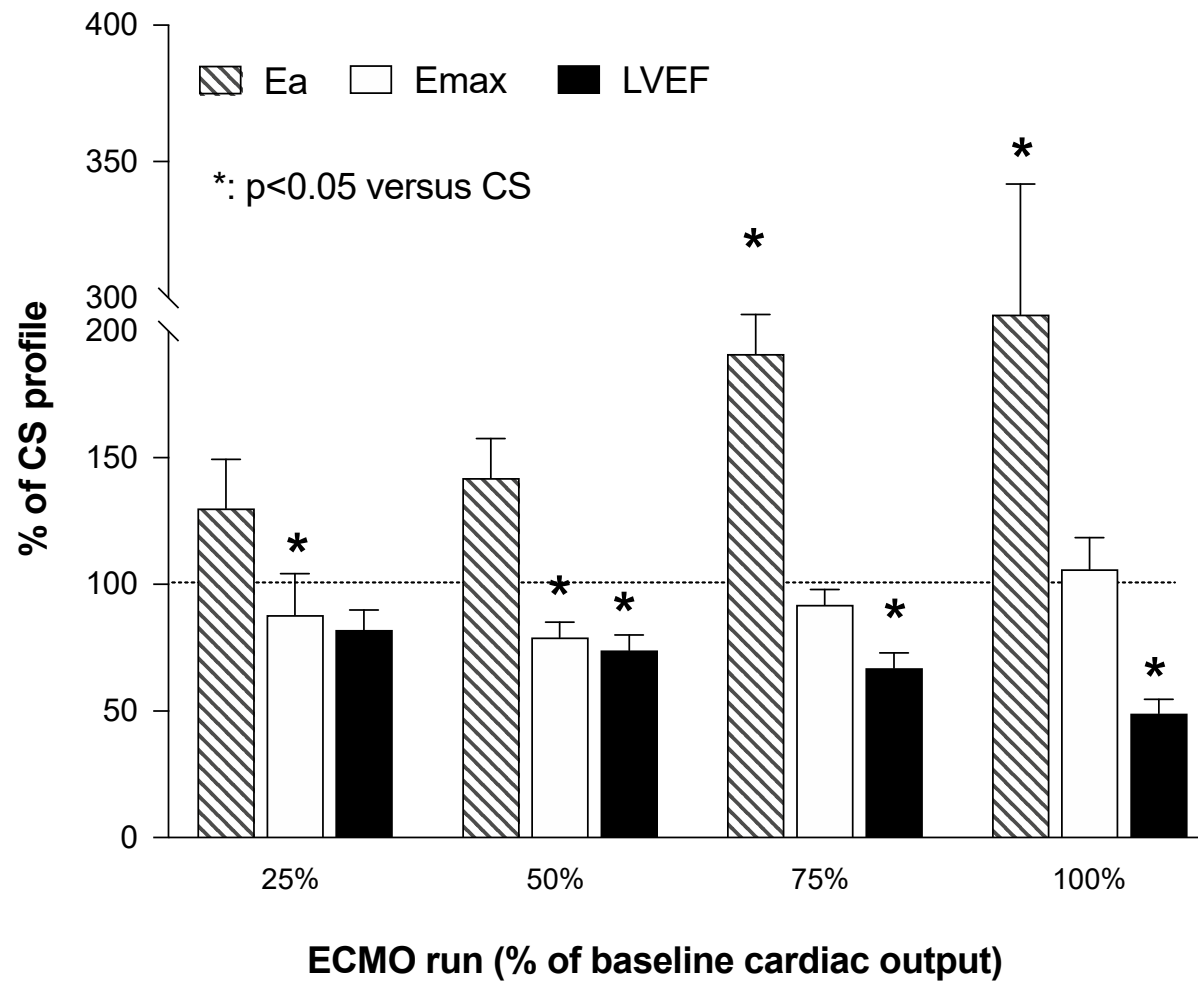

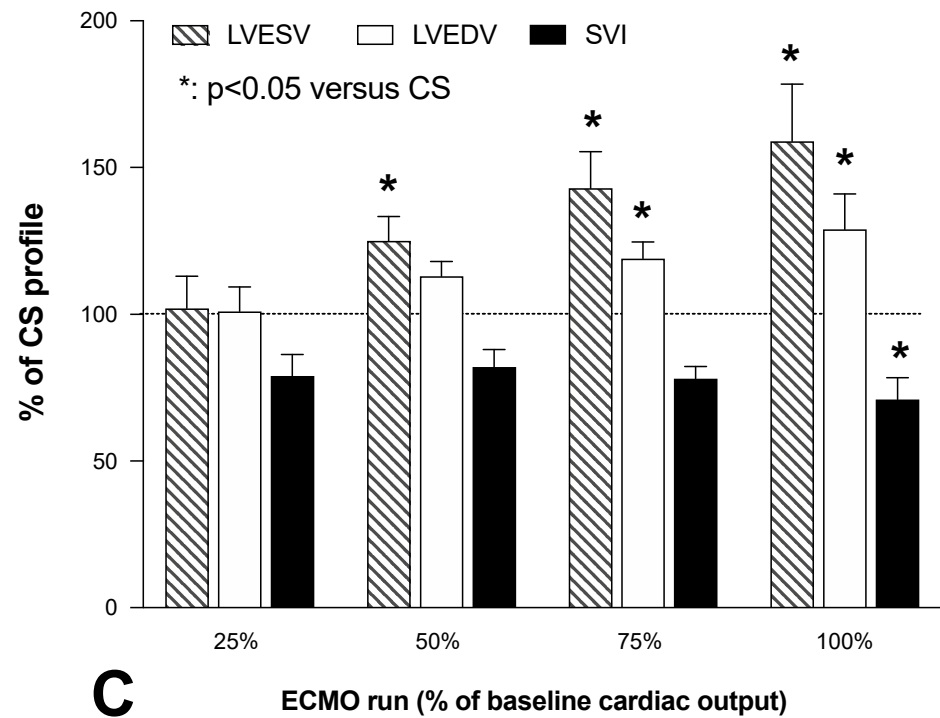
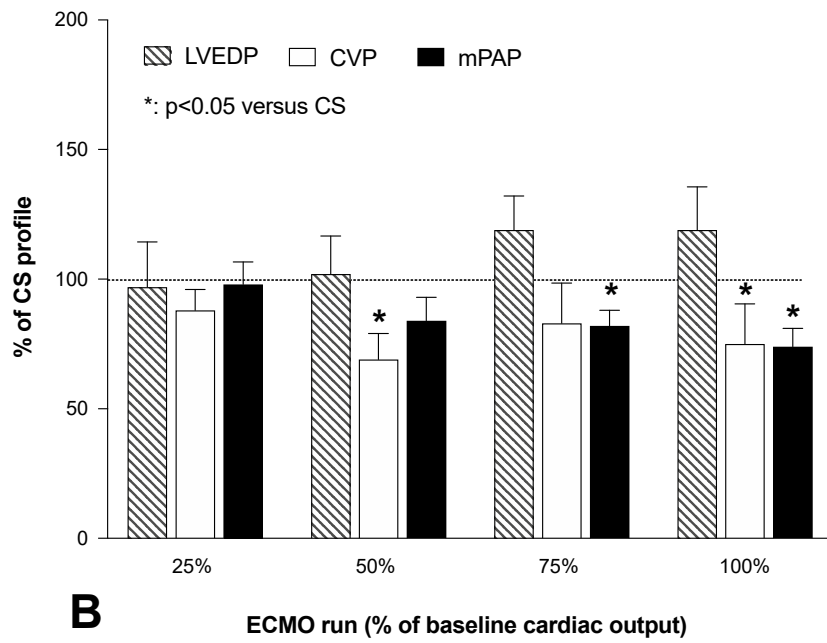

Experimental study in pigs (n=14)



Closed-chest profound cardiogenic shock model (microspheres)

PV catheter (LVEDV, LVEDP, EDPVR, ESPVR, PVA...)

Comparison of effects on intracardiac haemodynamics and end-organ perfusion

- 1) pECLS (3.2 L.min<sup>-1</sup> during 60 min and increased to maximum flow during 30 min)
- 2) IMPELLA (via femoral artery, P8 ≈ 3.2 L.min<sup>-1</sup> during 60 min)

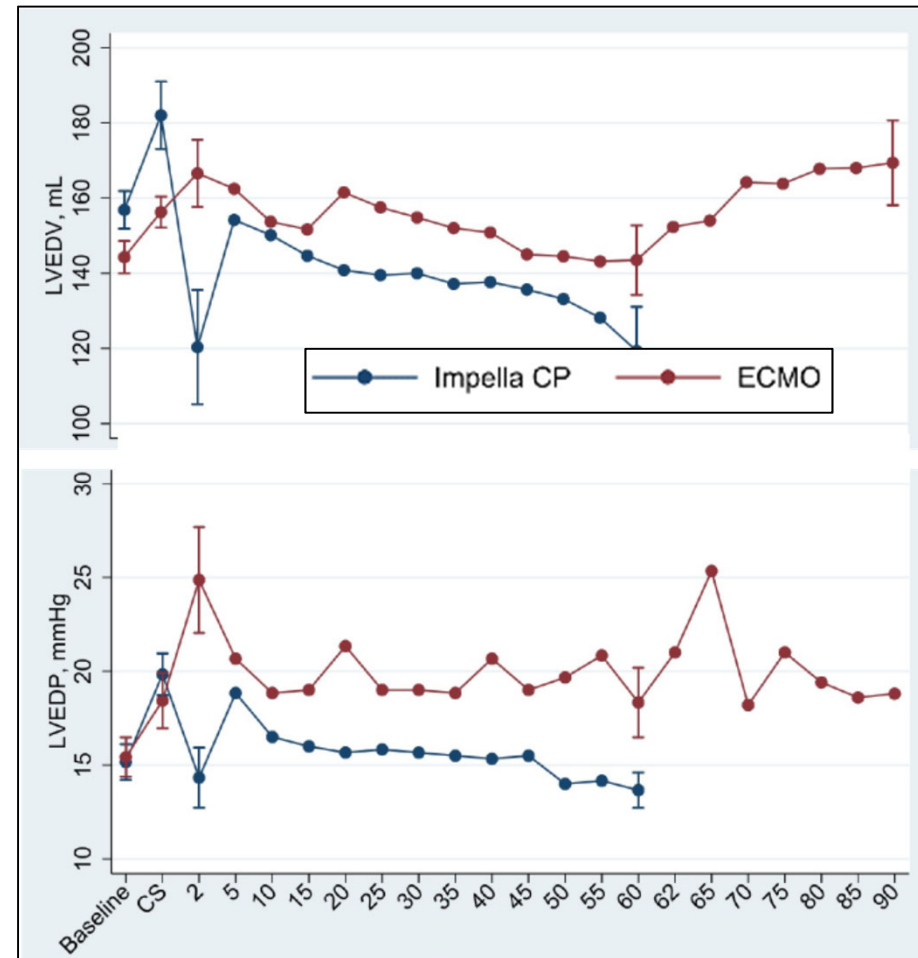

# INCREASE IN LEFT VENTRICULAR PRELOAD: INCOMPLETELY KNOWN UNDERLYING MECHANISM

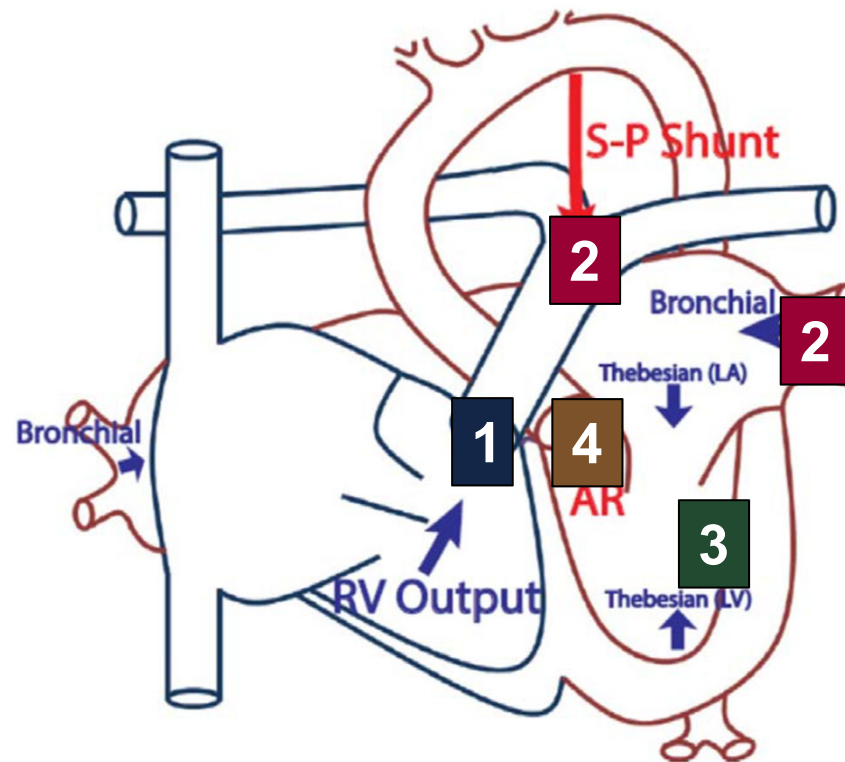

## Left ventricular overloading

- Continuous filling of left cardiac cavities
  - Residual pulmonary arterial flow
  - Bronchial circulation (broncho-pulmonary shunts)
  - Thebesian vein (myocardial wall veins draining into the left ventricle)
  - Increase in LV afterload (increase in end-systolic volume)
- Overloading of left ventricle (severe failing heart+++)
- Ventricular dilation and increase in parietal stress
- Subendocardial coronary hypoperfusion

# Hydrostatic pulmonary edema

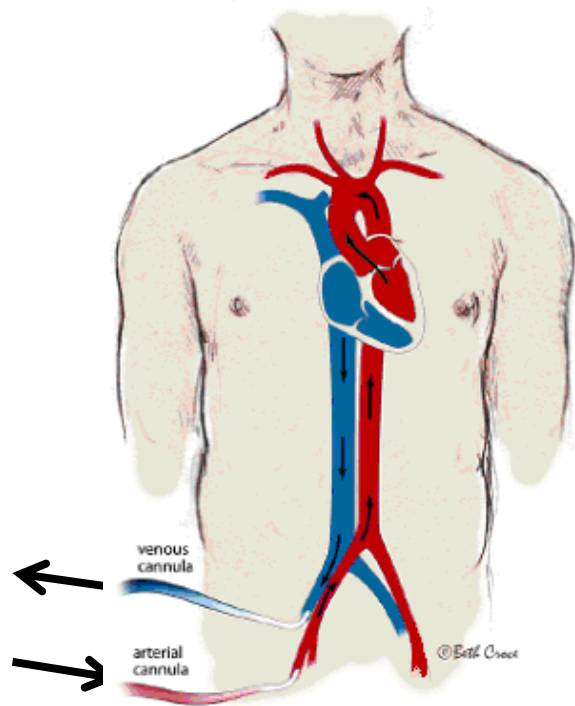

**Peripheral ECLS**

- Changes in ventricular loading conditions (increase afterload)
- Technical and anatomy dispositions
- Increase in parietal stress
- Risk of pulmonary edema (pulmonary morbidity)
- Alteration of sub-endocardial myocardial perfusion
- Alteration of myocardial recovery
- Increased risk when profound LV dysfunction (no « wash-out ») and in presence of MR ou AR

## Short term adverse effect of LV overload under peripheral VA ECMO

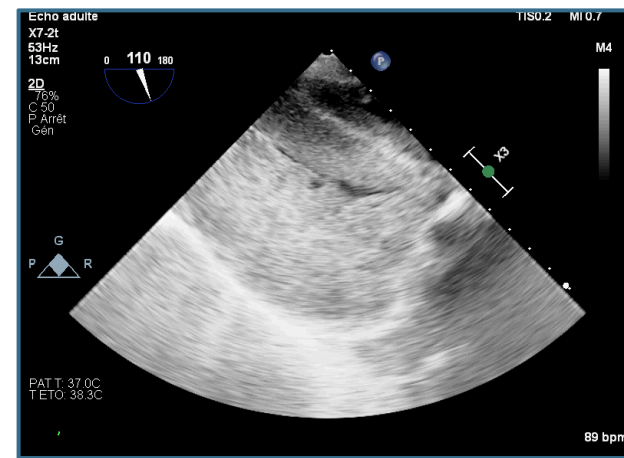
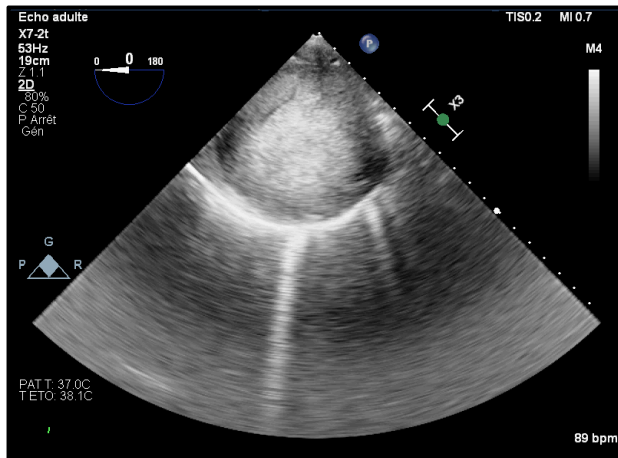
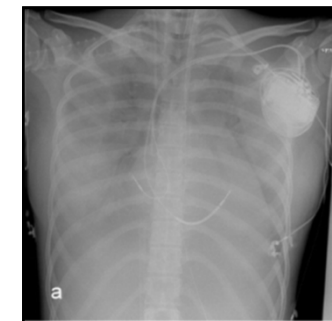



Table 2. Comparisons of intensive care unit events between survivors and nonsurvivors

Parameter	Survivors (n = 34)	Nonsurvivors (n = 47)	p
ECMO duration, days, median (IQR)	7 (5–10)	4 (1–12)	.04
Patients on MV, n (%)	30 (88)	47 (100)	.03
MV duration, days, median (IQR)	17 (8–25)	3 (2–10)	.0002
ICU stay, days, median (IQR)	21 (12–31)	4 (2–15)	<.0001
LVAD or BiVAD after ECMO, n (%)	5 (15)	1 (2)	.03
Heart transplant after ECMO, n (%)	7 (21)	2 (4)	.03
Day 3 SOFA score, mean ± SD	12 ± 5	17 ± 4	<.0001
Day 7 SOFA score, mean ± SD	10 ± 5	7 ± 6	<.0001
Packed red cells, n, mean ± SD	15 ± 11	11 ± 9	.05
Patients transfused, n (%)	34 (100)	43 (91)	.03
Renal replacement therapy, n (%)	13 (38)	36 (77)	.03
Major complication, n (%)	22 (65)	24 (51)	.27
Major bleeding	12 (35)	14 (30)	.60
Femoral vein thromboses	6 (18)	2 (4)	.06
Arterial ischemia	8 (24)	7 (15)	.39
Vena cava thrombosis	4 (12)	2 (4)	.24
Surgical wound infection	6 (18)	8 (17)	.99
Overt pulmonary edema	1 (3)	4 (9)	.39
Stroke	4 (12)	3 (6)	.44



ORIGINAL RESEARCH

Saura O et al. JACC 2025; 86:768-78

### Effect of ECMO Flow Variations on Pulmonary Capillary Wedge Pressure in Patients With Cardiogenic Shock

Patients (n=80) under peripheral VA-ECMO support for refractory cardiogenic shock for <48 hours, with a pulmonary artery catheter (PAC)

34% of patients with PCWP > 18 mmHg

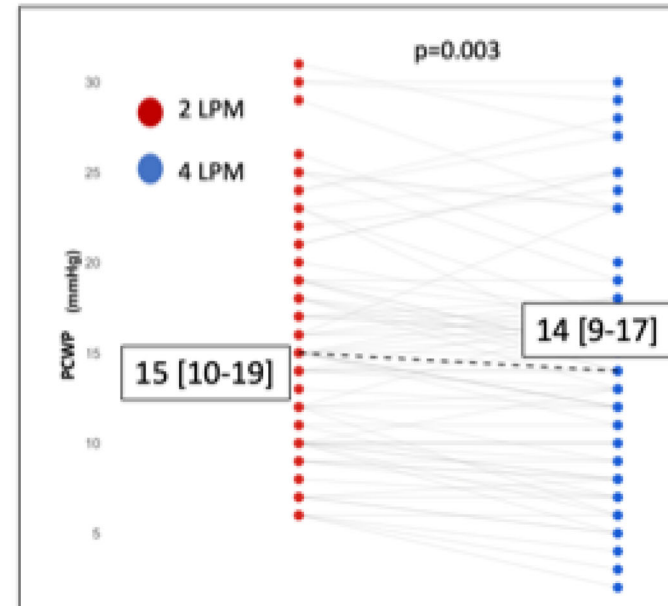
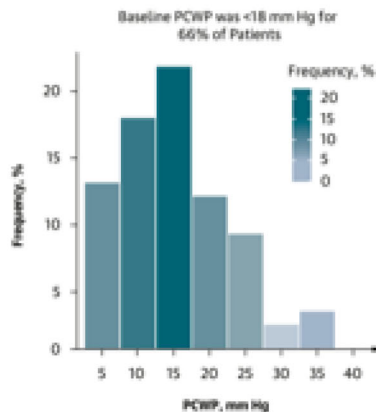

29 (36%) patients experienced a clinically relevant  $\geq 20\%$  reduction in PCWP, 5 (6%) patients a  $\geq 20\%$  increase in PCWP and 46 (58%) patients no clinically significant change in PCWP

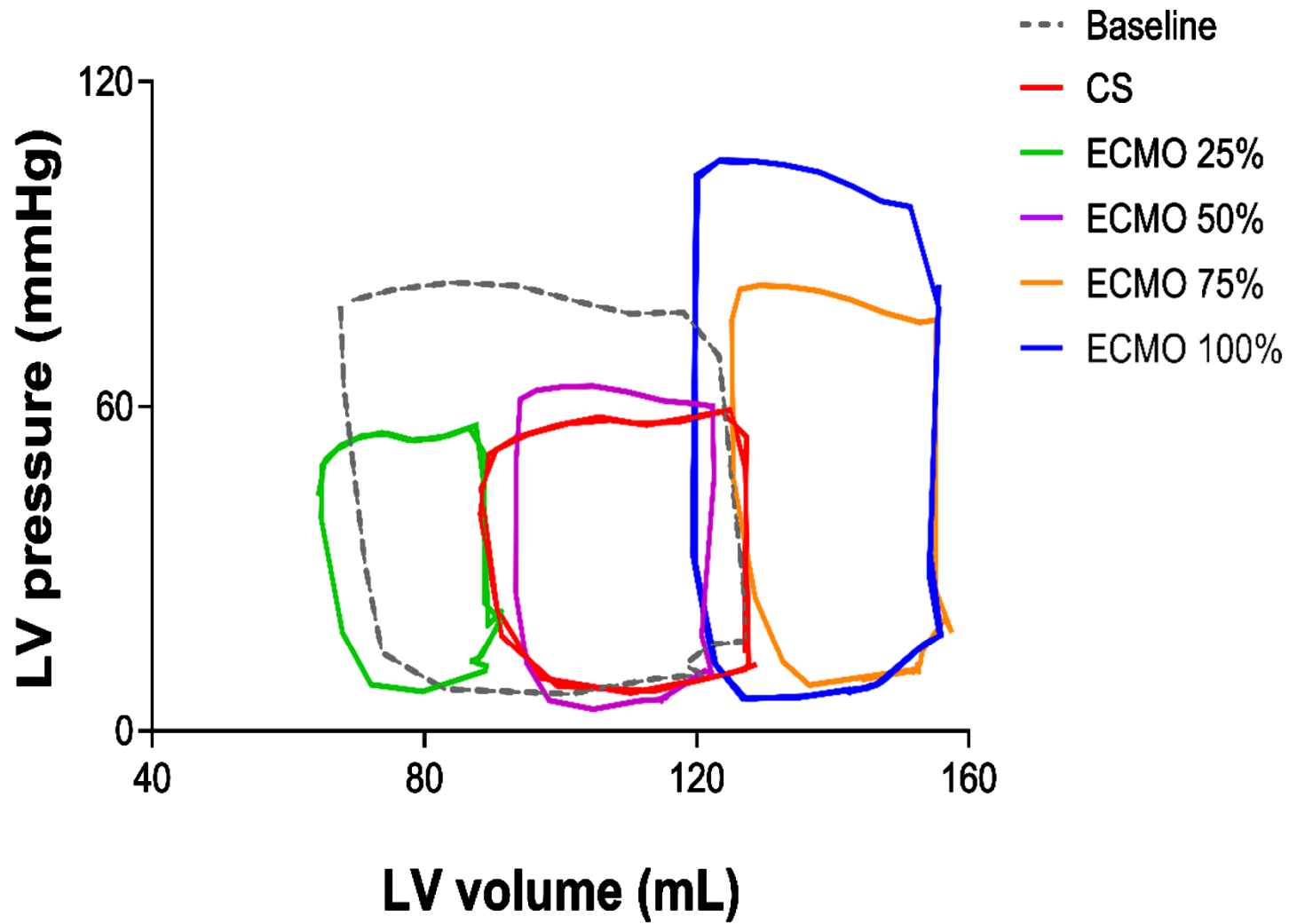

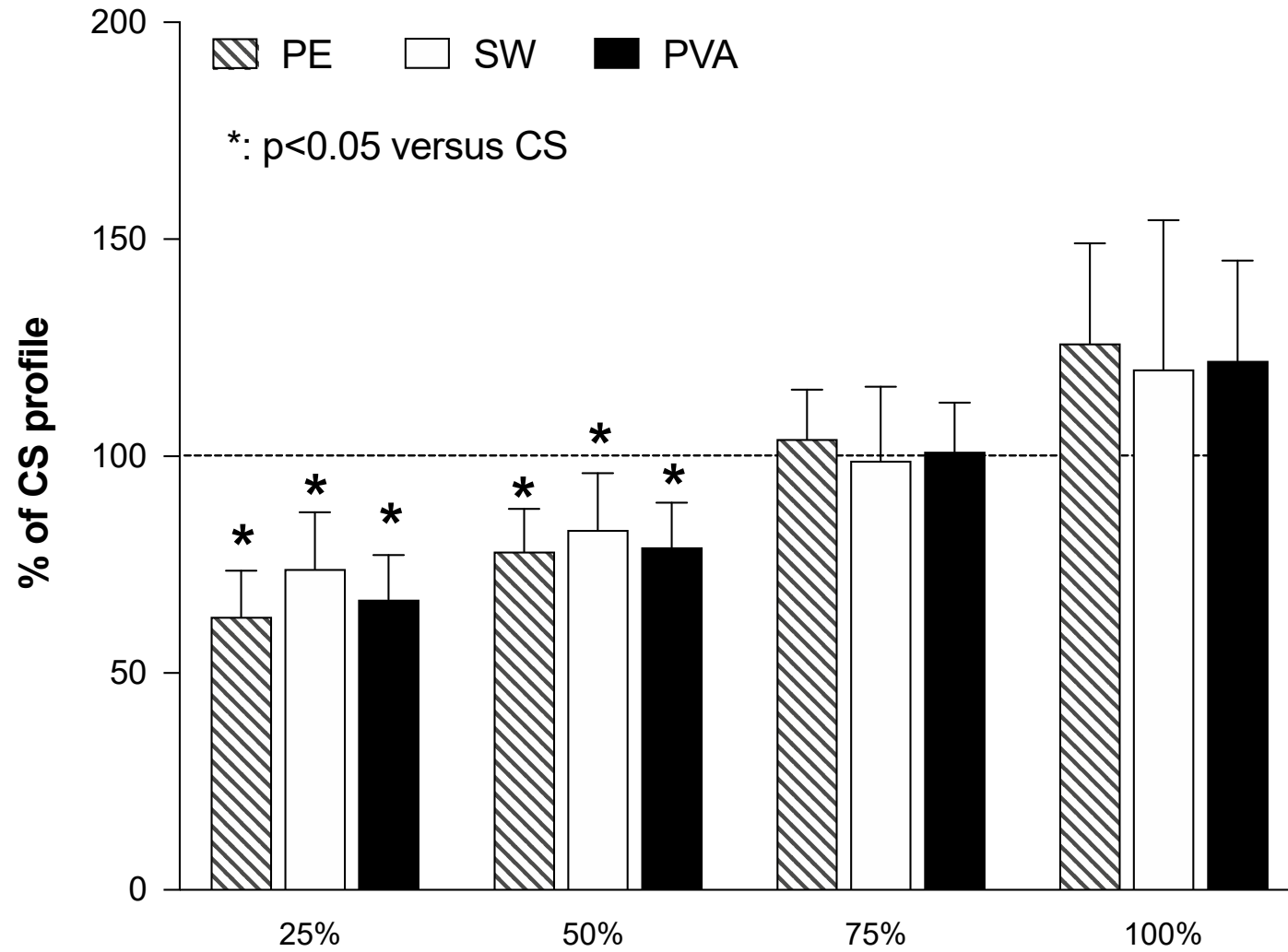

**B**

**ECMO run (% of baseline cardiac output)**

# ECLS and coronary perfusion

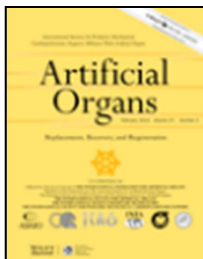
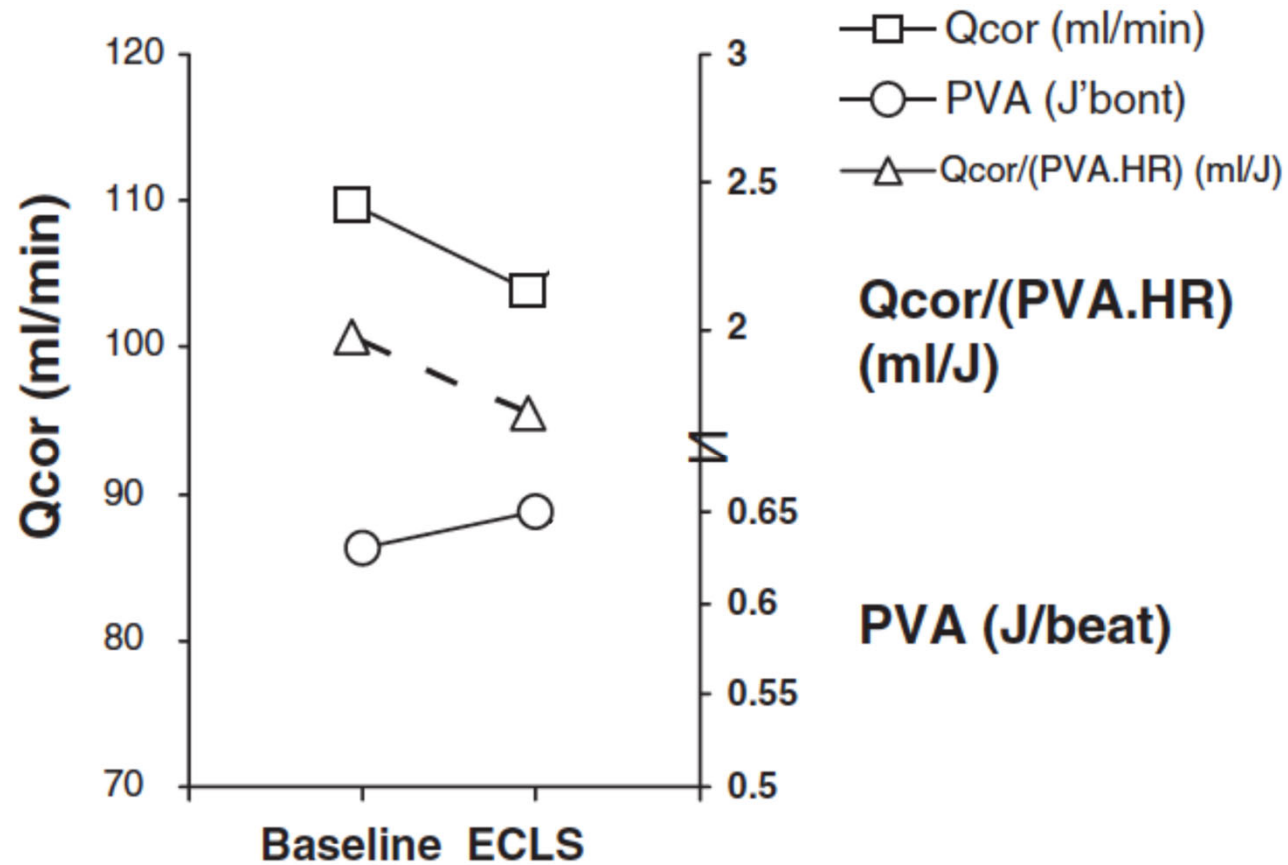

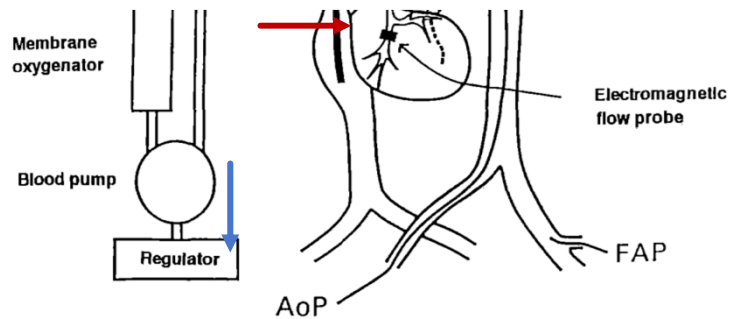

Fig. 1. Schematic diagram of the VA-ECMO circuit and experimental model. Note the placement of the electromagnetic flow probe on the coronary artery and the cannulation sites for hemodynamic measurements.

of 0.5 m<sup>2</sup> (MERASILOX-S; Senkoh Ika, Tokyo, Japan). A pair of sack-type pumps are driven by compressed air under automatic ECMO flow, which is monitored with an electromagnetic flowmeter, is automatically regulated by

**Methods.** The animals were anesthetized with ketamine (10 mg/kg). They were then intubated, and subjected to general endotracheal intubation with continuous intravenous ketamine (0.5 mg/kg per hour) and pancuronium bromide (0.1 mg/kg per hour).

increased in 20 ml · min<sup>-1</sup> · kg<sup>-1</sup> increments to a maximum bypass flow of 100 ml · min<sup>-1</sup> · kg<sup>-1</sup>. In nine of the 14 animals, the flow was then decreased in 20 ml · min<sup>-1</sup> · kg<sup>-1</sup> increments to a bypass flow of zero. All measurements were made after a 5-minute stabilization period at each flow rate.

**Statistical analysis.** Results are expressed as mean ± standard deviation. Analysis of variance and the paired t-test were used to analyze the data. Differences were considered statistically significant at a p value less than 0.05.

other hand, PaO<sub>2</sub> in the left ventricle and ascending aorta did not change significantly. The disparity in PaO<sub>2</sub> at the different sites became more prominent as the ECMO flow was increased to 100 ml · min<sup>-1</sup> · kg<sup>-1</sup>. The difference in PaO<sub>2</sub> between the left ventricle and ascending aorta was not significant. The ascending aorta was then perfused by blood that had been ejected by the left ventricle. There were no significant changes in arterial carbon dioxide tension at the different

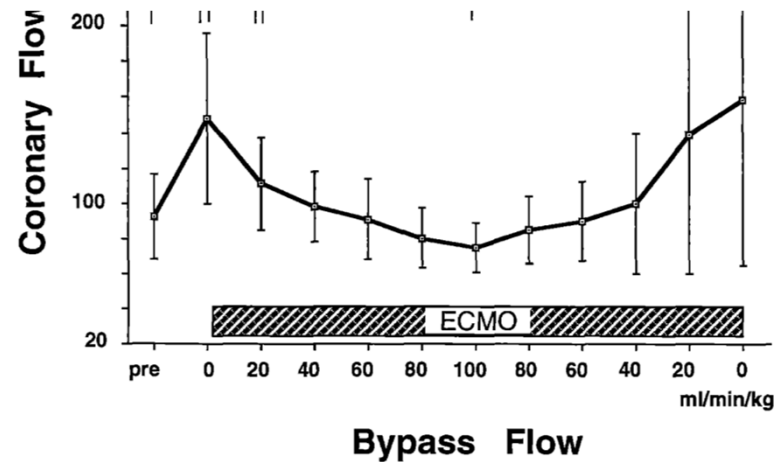

Fig. 2. CAF as a function of bypass flow. Ventilator settings were reduced to 10 cm H<sub>2</sub>O peak inspiratory pressure and 10 breaths/min respiratory rate between period before VA-ECMO (*pre*) and the initiation of VA-ECMO. CAF increased significantly with reduced ventilator settings and decreased significantly shortly after the initiation of ECMO. CAF continued to fall with increases in the ECMO flow. As the ECMO flow was decreased from the maximum of 100 ml · min<sup>-1</sup> · kg<sup>-1</sup> to 20 ml · min<sup>-1</sup> · kg<sup>-1</sup>, CAF increased to a level as before VA-ECMO. *gLV*, Grams of left ventricle, wet weight; *SD*, standard deviation.

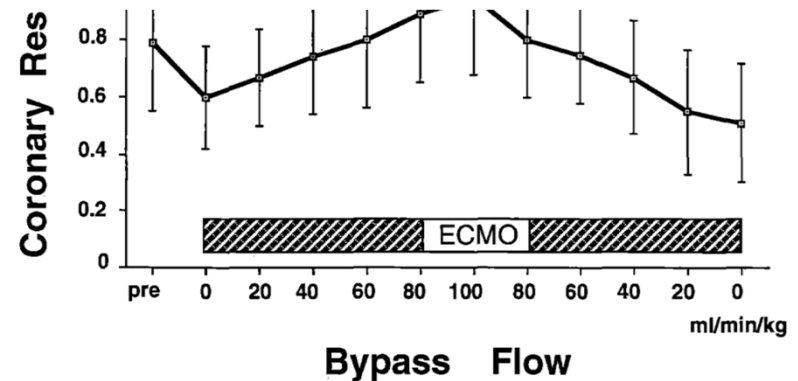
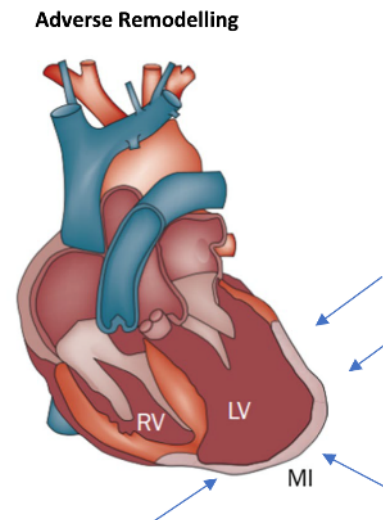

Fig. 4. Coronary resistance as a function of bypass flow. The coronary resistance decreased with reduced ventilator settings and increased with increases in bypass flow. The difference in coronary resistance between the peak ECMO flow (100 ml · min<sup>-1</sup> · kg<sup>-1</sup>) and minimal ECMO flow (20 ml · min<sup>-1</sup> · kg<sup>-1</sup>) was statistically significant (p < 0.01). The coronary resistance returned to baseline as the bypass flow was reared. *gLV*, Grams of left ventricle, wet weight; *SD*, standard deviation.

# VENTRICULAR REMODELING

- 30% of patients after MI (infarct size is the principal risk factor)
- Main origin of chronic heart failure after MI
- Increased parietal stress (+++) and myocardial work
- Increased myocardial oxygen consumption
- Decreased coronary blood flow (+++)
- Increased compliance of infarcted zone
  - Thinning of myocardial wall
  - Left ventricular dilation



*Deja MA et al. Circulation 2012; 125:2639-48*

*Michler RE et al. J Thorac Cardiovasc Surg 2013; 146:1139-45*

*Jackson BM JACC 2002; 40:1160-7*

# INCREASED VENTRICULAR WALL STRESS AS AN UNDERLYING MECHANISM OF CARDIAC REMODELING

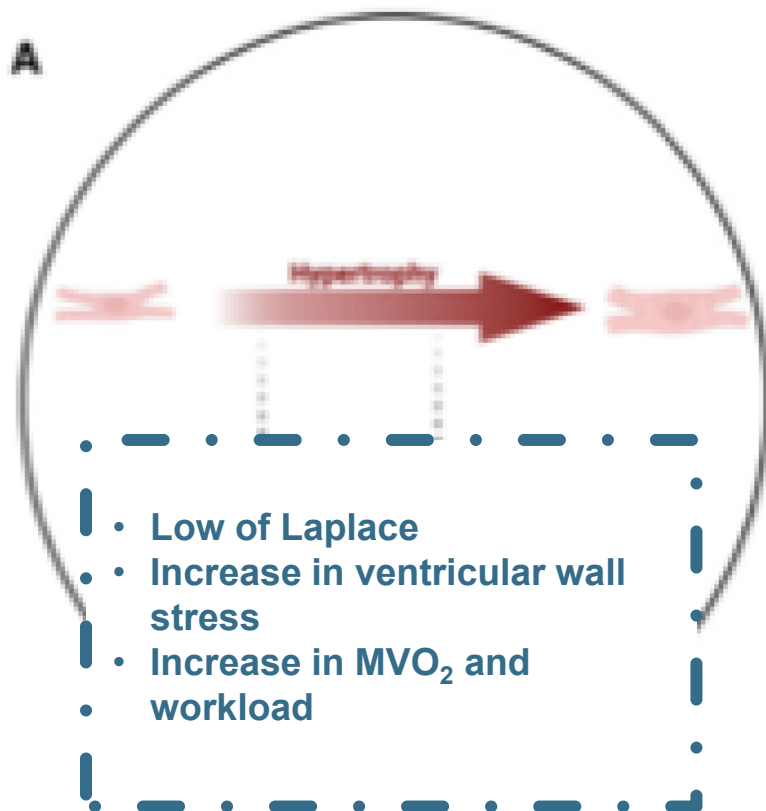

## Adverse left ventricular remodeling

- Adaptive or maladaptive LV response
- To mechanical (increase LV loading conditions, wall stress) and non-mechanical (cellular, extra-cellular, inflammation, neuro-hormonal) changes

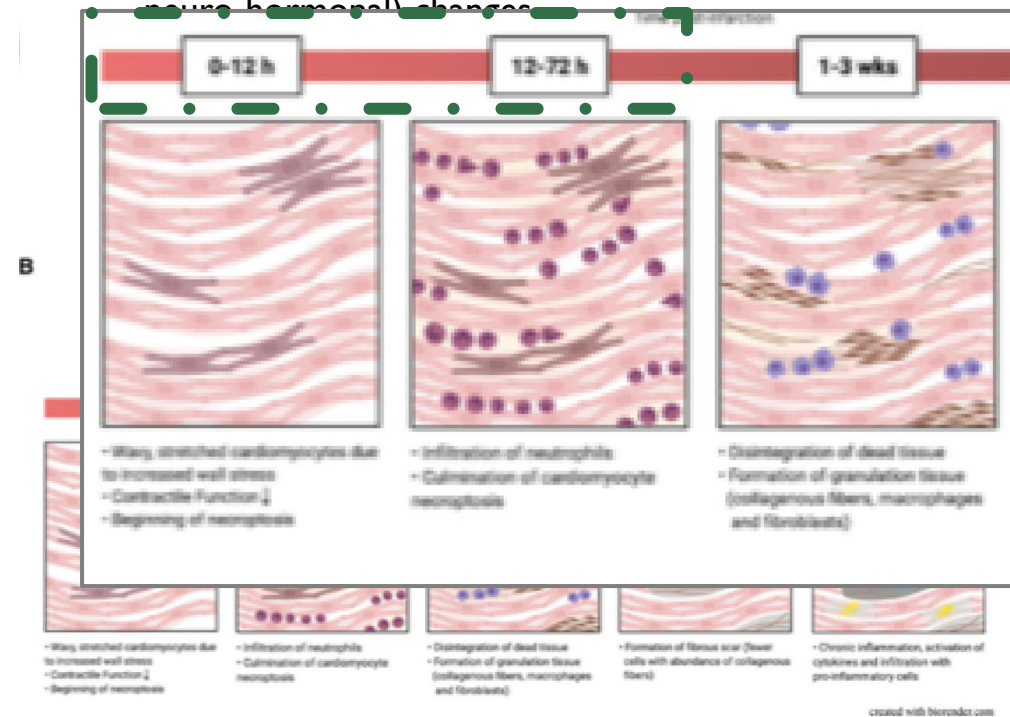

# CHRONIC HEART FAILURE AFTER MYOCARDIAL INFARCTION

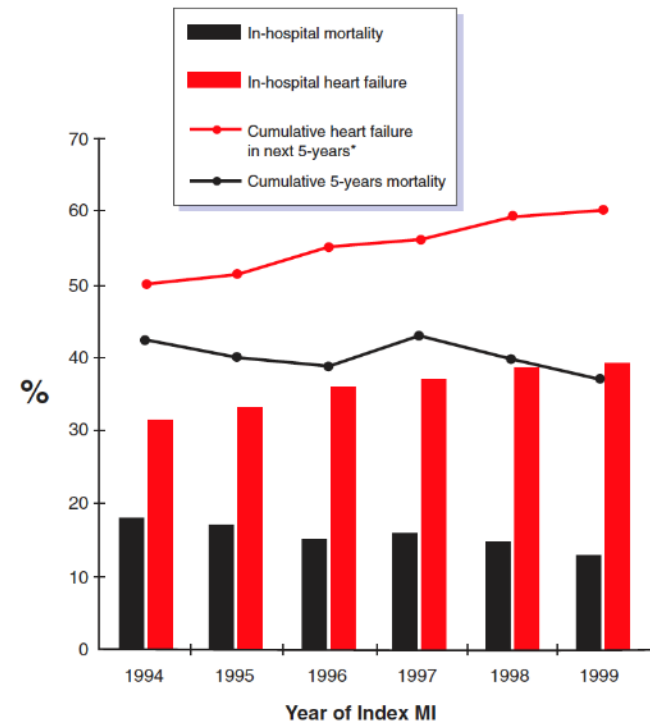
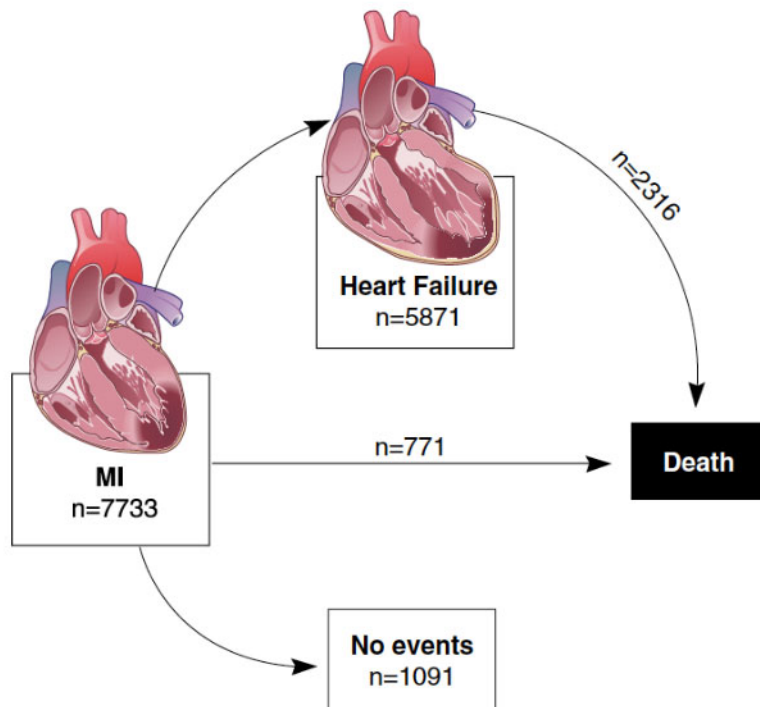

Ezekowitz JA et al. *J Am Coll Cardiol* 2009;53:13-20

## LV DILATION ASSOCIATED WITH A WORSE PROGNOSIS

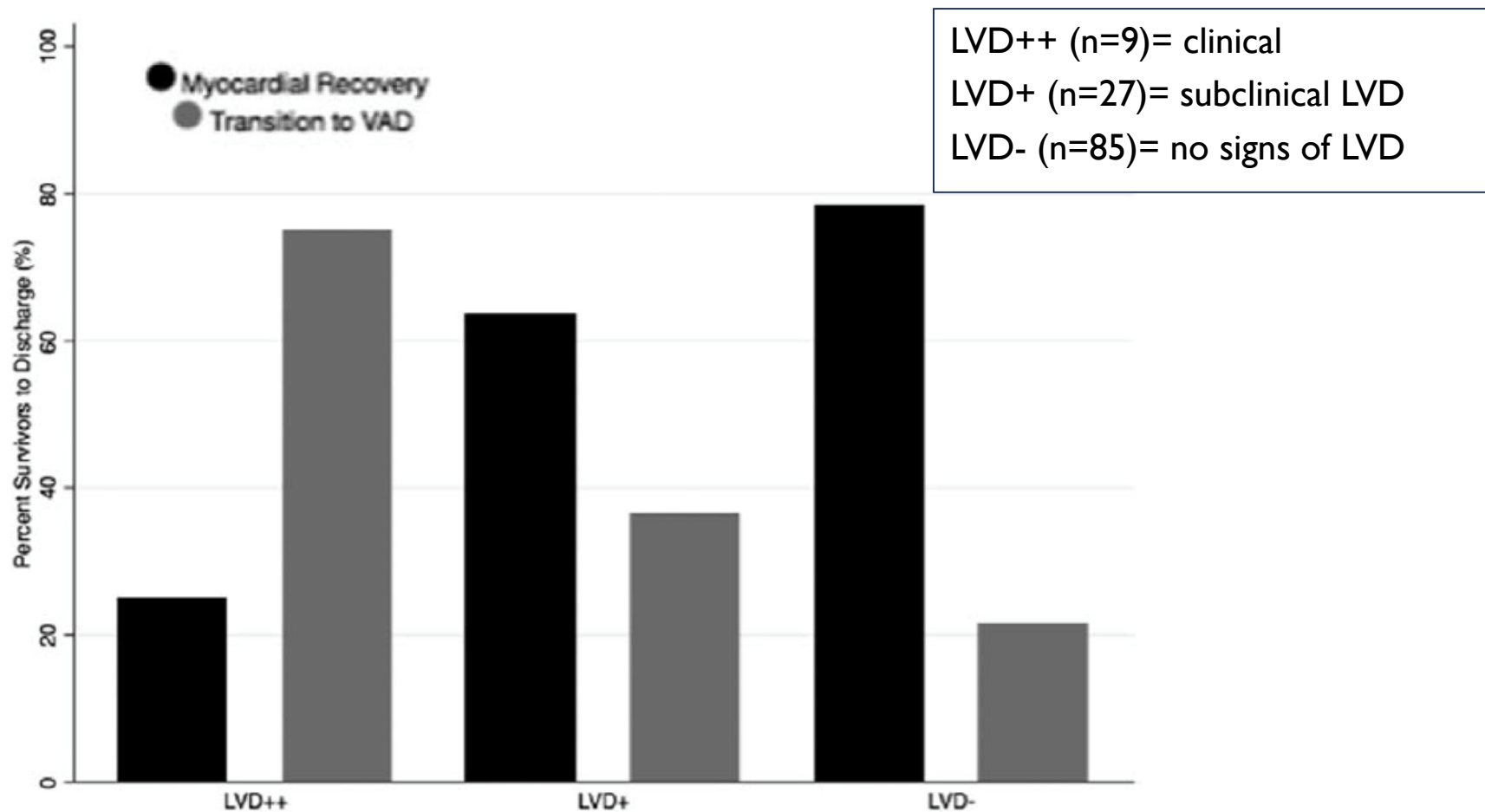

## MAIN OBJECTIVES OF SHORT-TERM MECHANICAL CIRCULATORY SUPPORT

- Restore end-organ perfusion for limiting multi-organ failure (**supply**)
  - ✓ Blood flow, systemic pressure, oxygenation
  - ✓ Cerebral, coronary, renal, hepatic and mesenteric perfusion...
  - ✓ Poor prognostic of multi-organ failure
  
- Limit ventricular congestion (**assist**)
  - ✓ Volume and pressure unloading +++
  - ✓ Reduce risk of pulmonary edema (prolonged MV, VAP...) [**short term**]
  - ✓ Reduce the risk of ventricular remodeling [**Mild or long-term**]

## ASSESSMENT OF LV PRELOAD

- Pulmonary capillary wedge pressure (PCWP) or pulmonary artery occlusion pressure (PAOP)
- Estimation of LA pressure
- Upper limit 18 mmHg

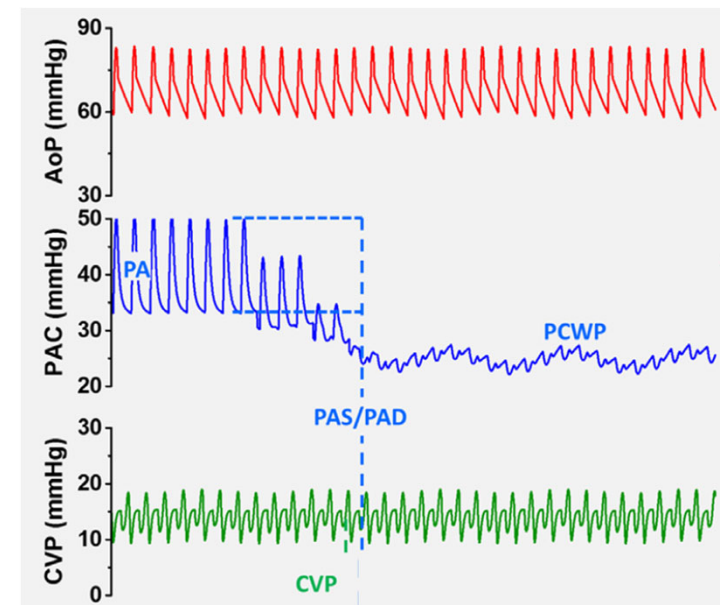

# Value of Hemodynamic Monitoring in Patients With Cardiogenic Shock Undergoing Mechanical Circulatory Support

Abhinav Saxena<sup>1</sup>, MD  
A. Reshad Garan, MD  
Navin K. Kapur, MD  
William W. O'Neill, MD  
JoAnn Lindenfeld, MD  
Sean P. Pinney, MD  
Nir Uriel, MD  
Daniel Burkhoff, MD, PhD  
Morton Kern, MD

## SUMMARY

“PACs should be used in all patients undergoing MCS to monitor effectiveness, optimize device settings , assess the need for escalation and guide timing and rate of weaning...”



## ELSO Interim Guidelines for Venoarterial Extracorporeal Membrane Oxygenation in Adult Cardiac Patients

*« A pulmonary artery catheter should be considered during VA ECMO, as it allows detection of elevated left-sided filling pressures, which may prompt the use of adjunct LV unloading techniques... »*

*« ...PAC-based continuous cardiac output monitoring during VA ECMO is inaccurate but it may provide an indication of pulmonary artery flow and aid in weaning... »*

**Table 8. Clinical Monitoring During Venoarterial Extracorporeal Membrane Oxygenation**

- 
- Invasive arterial blood pressure monitoring/right radial artery**
- Pulse pressure—measure of native contractility vs. ECMO blood flow
  - Oxygen saturation—measure of oxygenation in proximal aortic arch/detection of differential oxygenation
- Pulse oximetry/right hand**
- Oxygen saturation—measure of oxygenation in proximal aortic arch/detection of differential oxygenation
- Pulmonary artery catheter**
- Detect elevated left-sided filling pressure
  - Support indication for adjunct LV unloading
  - Continuous cardiac output monitoring as indication of residual pulmonary artery flow (alternatively, residual pulmonary artery flow can be monitored by measuring end-tidal CO<sub>2</sub>)
- Echocardiography**
- Early cardiac diagnostics and identification of contraindications to VA ECMO
  - Visualization of proper vascular access and guidance cannulation
  - Optimal tailoring of ECMO support
  - Serial assessment of hemodynamic and cardiac conditions
  - Cardiac assessment during weaning trial
- Electrocardiography**
- Consider continuous, multilead electrocardiographic monitoring
- NIRS**
- Monitoring of limb (single and bilateral comparison) and brain perfusion
- 

ECLS, extracorporeal life support; LV, left ventricular; NIRS, near-infrared spectroscopy; VA ECMO, venoarterial extracorporeal membrane oxygenation.

## TO ASSESS RIGHT CAVITIES UNLOADING AND RESIDUAL PULMONARY FLOW

- Central venous pressure < 10 mmHg
- Diastolic pulmonary partial pressure < 20 mmHg
- Cardiac index between 1.0 and 2.0 L.min<sup>-1</sup>.m<sup>-2</sup>



Puajara D et al. Semin Thoracic Surg 2015;27:17-23

## The State of the Art in Extracorporeal Membrane Oxygenation

### Pharmacological unloading

#### MANAGEMENT CONSIDERATIONS

Inotropic support and ventricular assist devices (eg, Impella, Abiomed; intra-aortic balloon pump; TandemHeart trans-septal cannula) should be maintained to facilitate the left-side chamber unloading if cardiac recovery is a possibility.

## CLINICAL IMPLICATIONS

- Avoid over-assistance (blood flow to meet the metabolic demand ( $SvO_2$ ))
- Screening risk of pulmonary edema (TTE, Swan-Ganz catheter PCWP < 16-18 mmHg...)



# Cardiogenic shock in 2024: insight the complex reality of ECLS and left ventricular unloading strategies

*Intensive Care Med.* 2024;50:971-3

Aurore Ughetto<sup>1\*</sup>, Benedikt Schrage<sup>2</sup> and Clément Delmas<sup>3,4</sup>

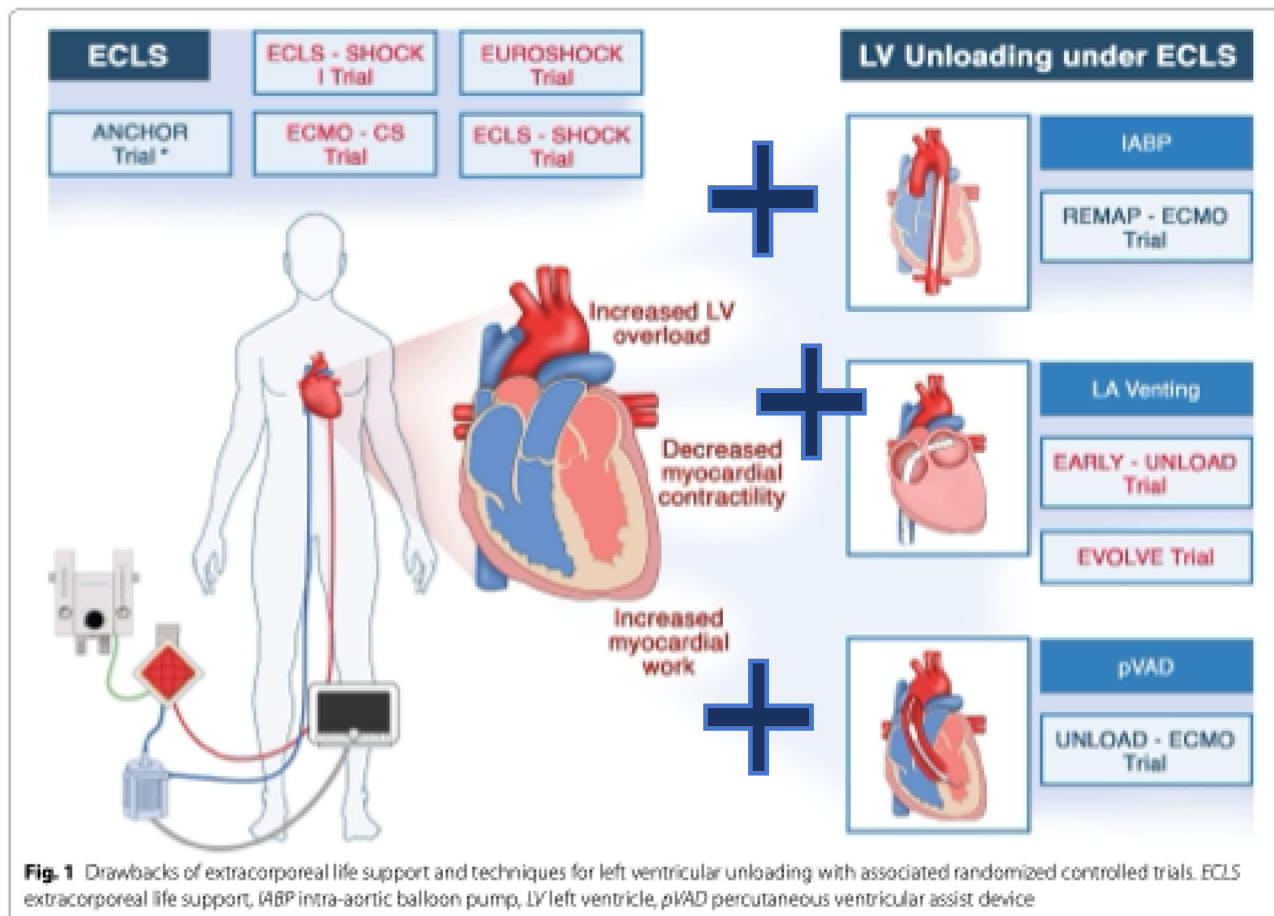

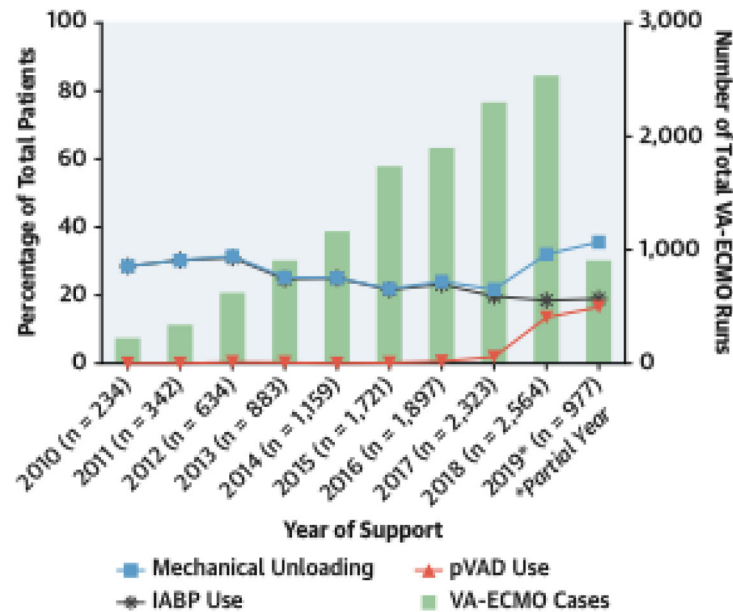

- ELSO registry 2010-2019 (n=12 734)
- 26.7% of patients with LV unloading
- No influence by timing (upfront versus delayed)

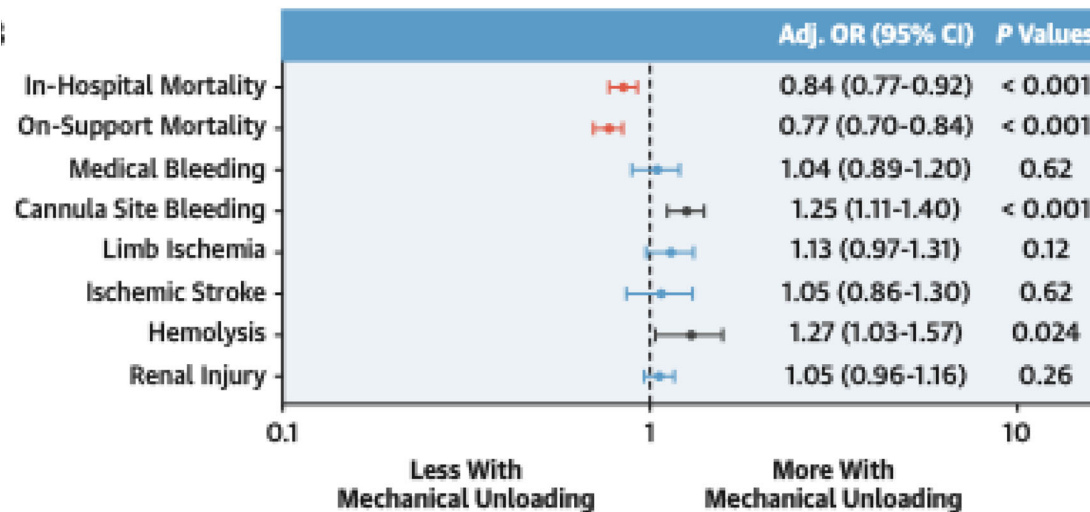

# Intra-aortic balloon pump (IABP)

## Improvement energetic balance of myocardium

- Decrease  $MvO_2$  (loading conditions)
- Increase myocardial perfusion

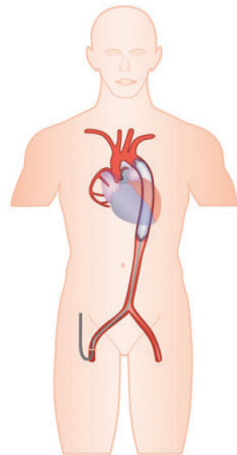

Improvement of end-organ  
perfusion (Pulsatility)

- Increase diastolic aortic pressure 30 à 70% (rapid inflation r)
- Decrease systolic aortic pressure of 5-15% (rapid deflation)
- Decrease LV afterload
- Decrease LV preload
- Decrease HR (10%)
- Increase SV and CO (5-10%).

*deWaha S et al. Vascular Pharmacology 2014; 61:30-34*  
*Ro SK et al. Eur J Cardiothorac Surg 2014; 46:186-92*  
*Aso S et al. Crit Care Med 2016; 44:1974-9*

# Changes in PCWP

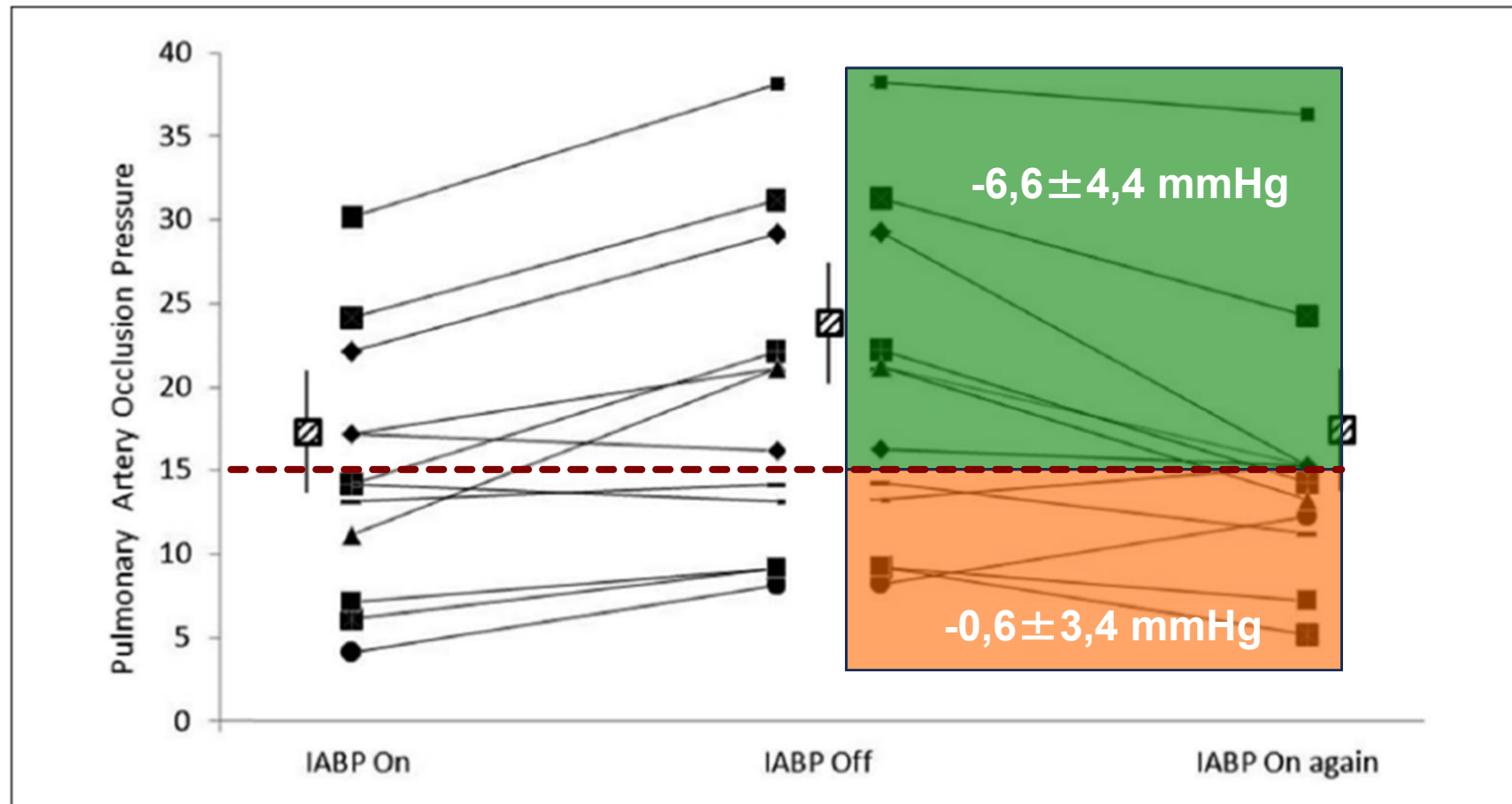

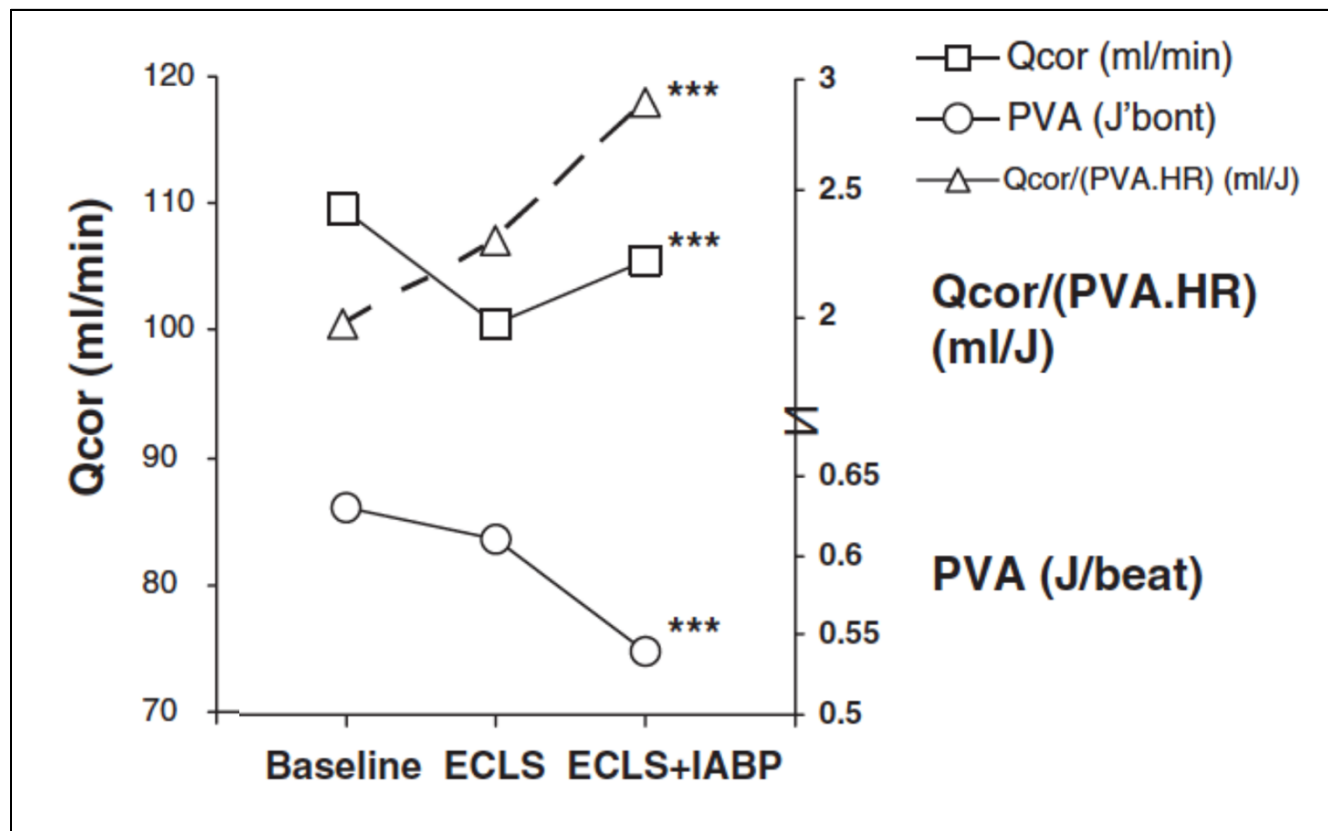

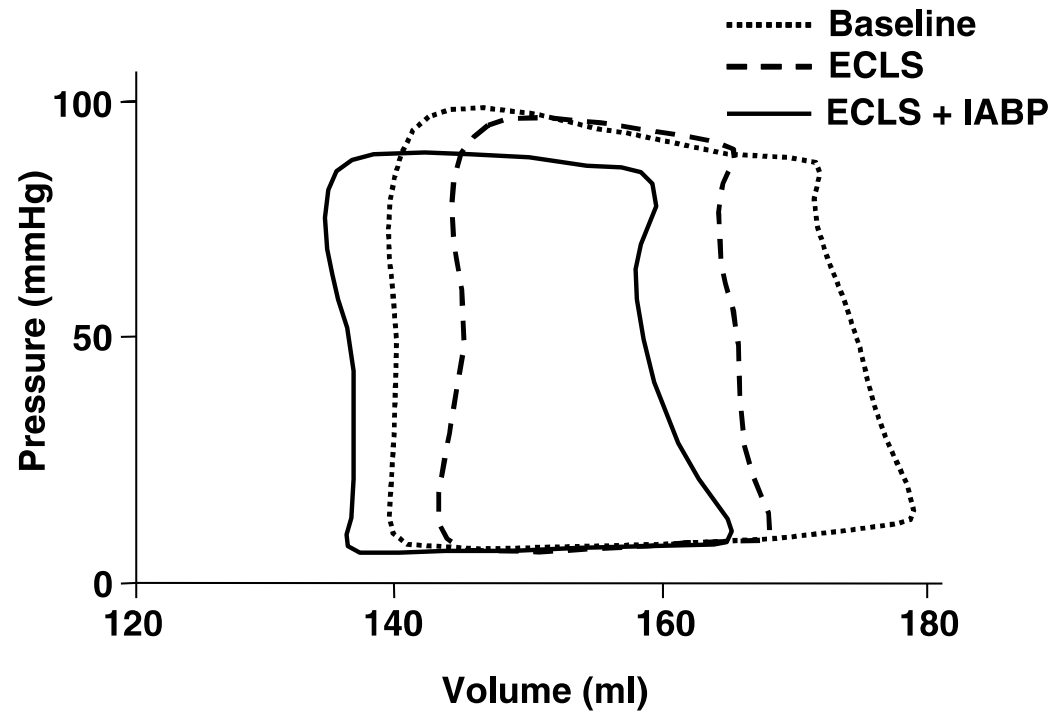

Decrease in LVEDP and LVEDV

Decrease in SV

Reduction of myocardial oxygen consumption

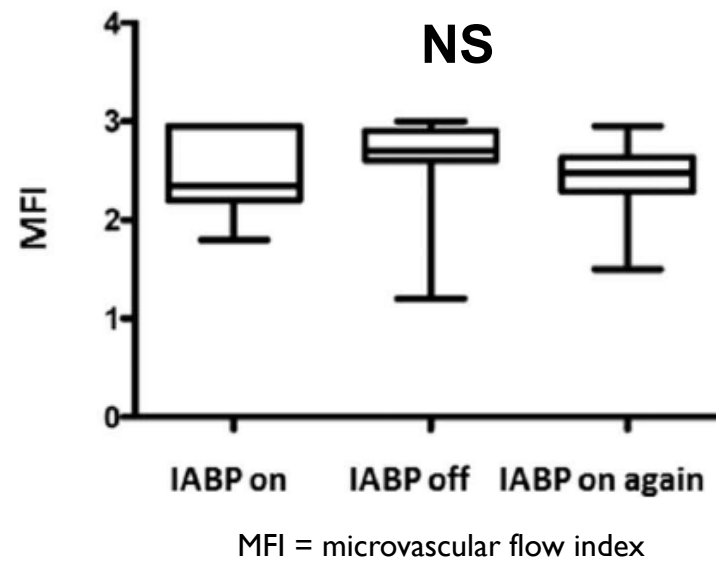
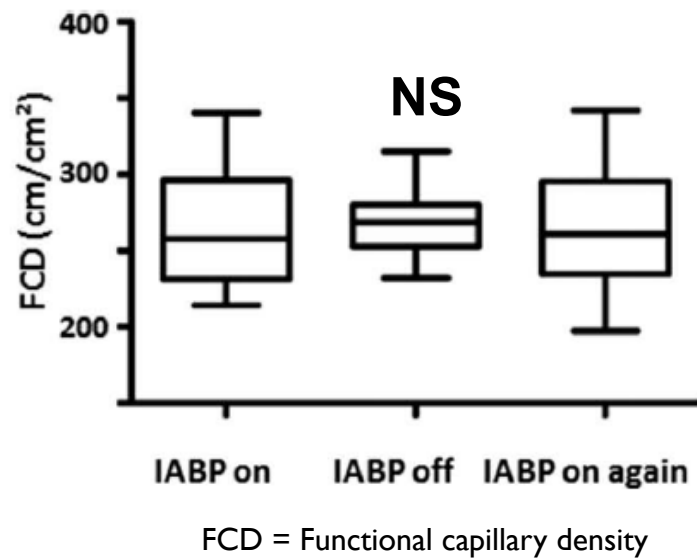

- Meta-analysis of 22 studies (2000-18, n= 4653). The IABP was used in nearly 44% of VA ECMO patients

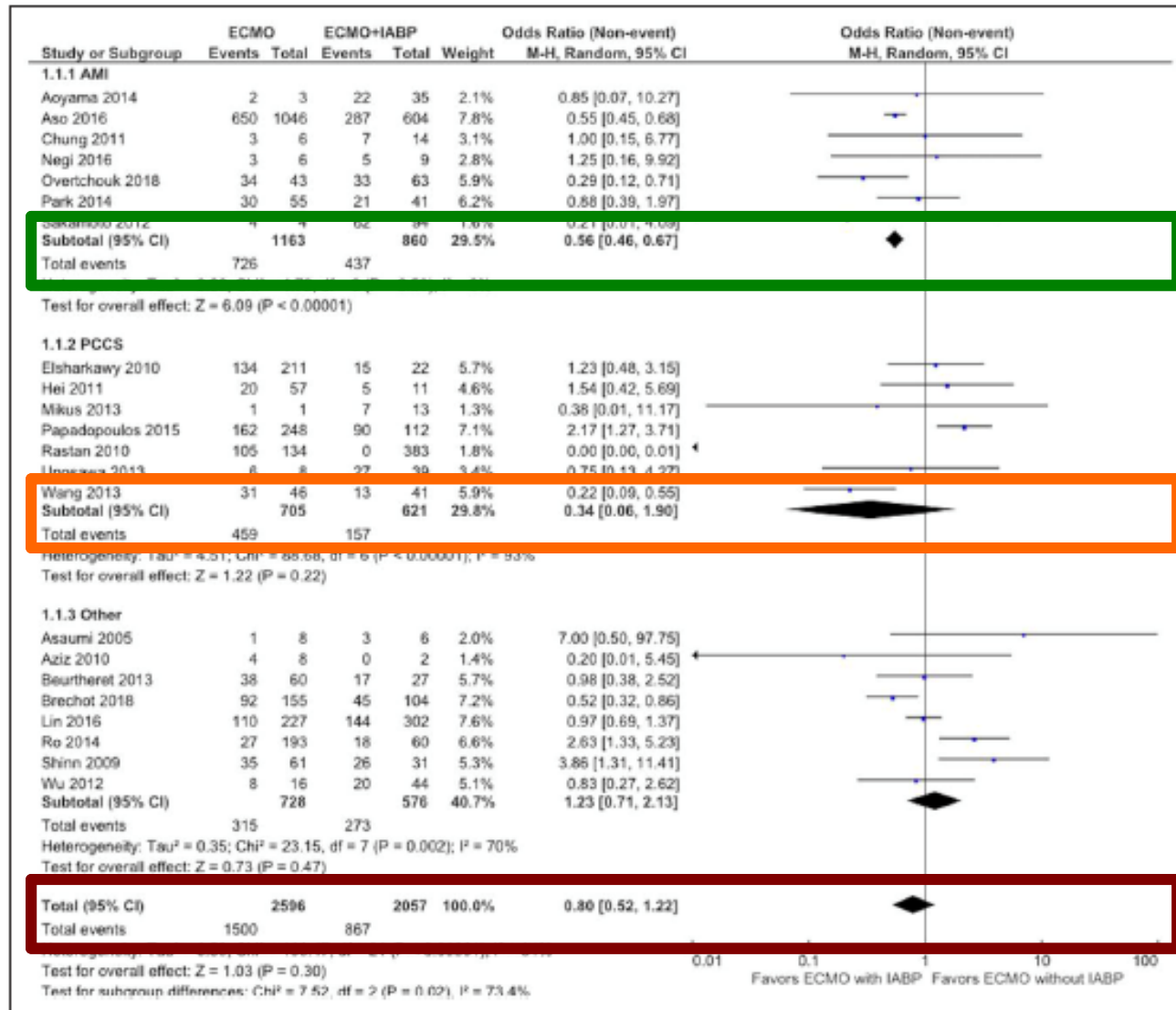

# INTRA-CARDIAC HAEMODYNAMIC EFFECTS OF IMPELLA DEVICE

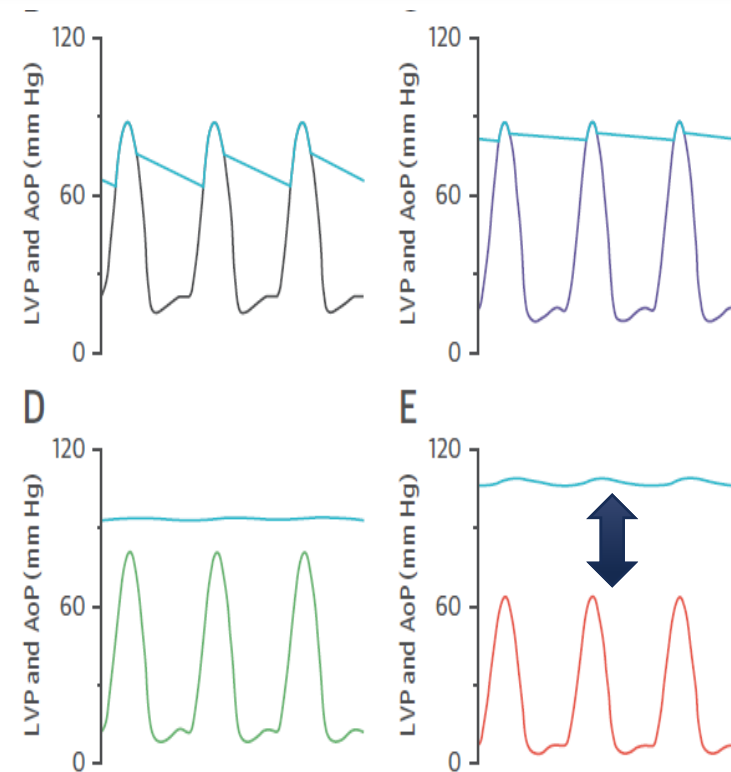
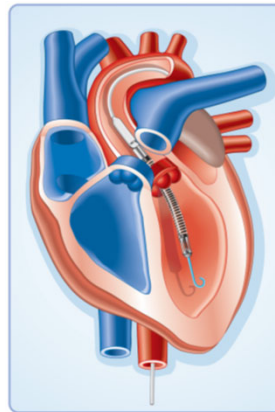
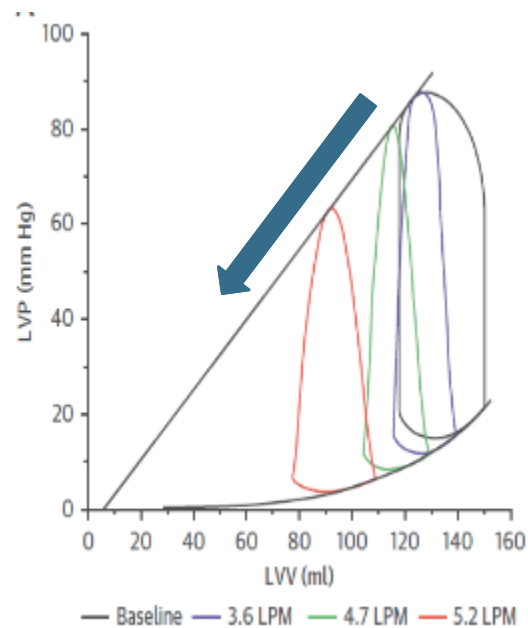

LV unloading and reduction of myocardial work

Arterio-Ventricular decoupling

# Successful left ventricular decompression following peripheral extracorporeal membrane oxygenation by percutaneous placement of a micro-axial flow pump

Jouan J et al. J Heart Lung Transplant 2010;29:135-6

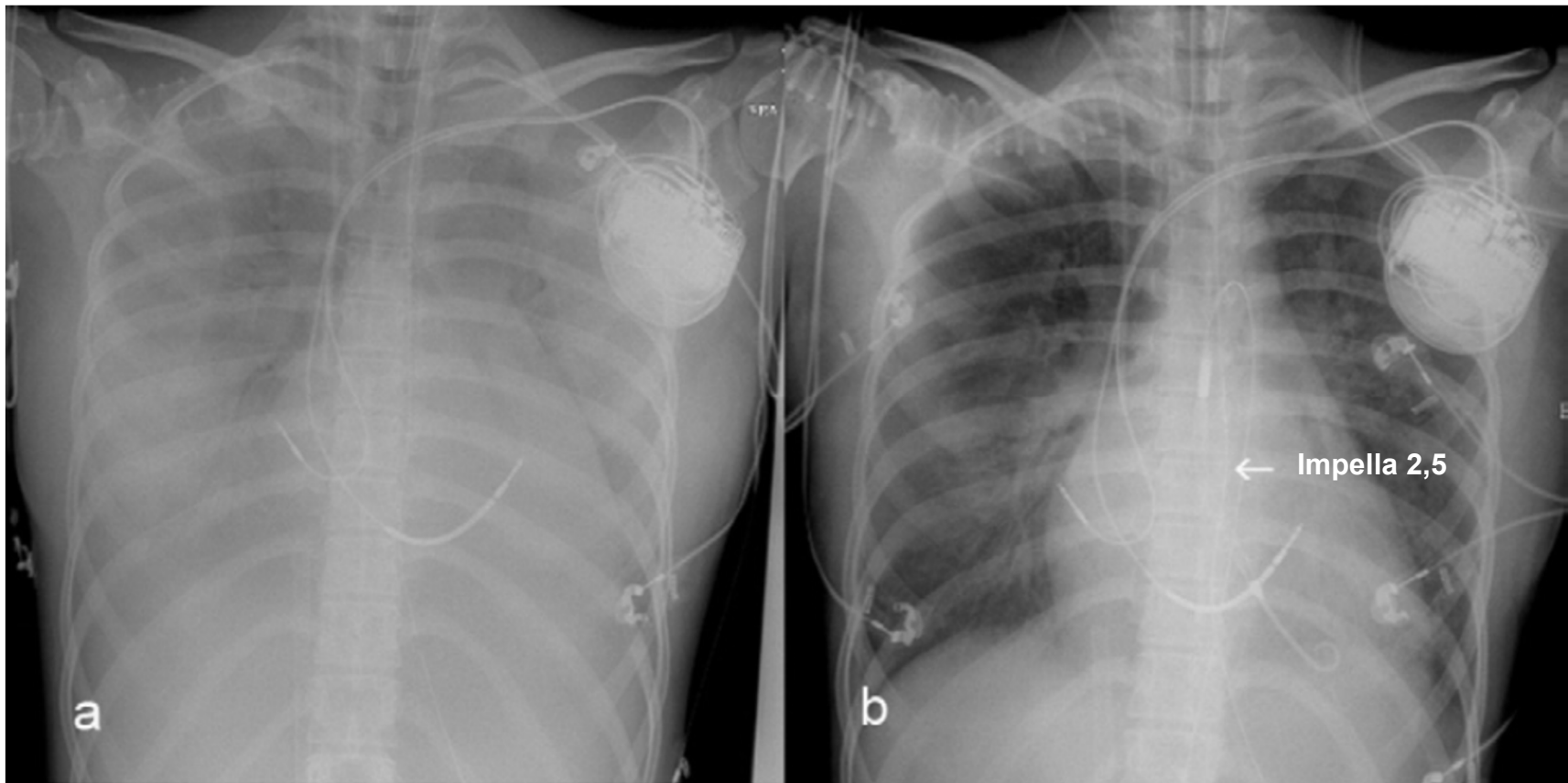



## Left Ventricular Unloading Is Associated With Lower Mortality in Patients With Cardiogenic Shock Treated With Venoarterial Extracorporeal Membrane Oxygenation

### Results From an International, Multicenter Cohort Study

Variable	Matched study cohort		
	VA-ECMO, matched (n=255)	ECMELLA (n=255)	P value
Bleeding complications			
Intracerebral bleeding	16/182 (8.8)	18/216 (8.3)	0.99
Hemorrhagic stroke	10/181 (5.5)	7/216 (3.2)	0.38
Severe bleeding	45/252 (17.9)	98/255 (38.4)	<0.01
Moderate bleeding	74/192 (38.5)	123/241 (51.0)	0.01
Intervention resulting from bleeding	33/201 (16.4)	47/251 (18.7)	0.61
Hemolysis	43/192 (22.4)	79/235 (33.6)	0.01
Ischemic complications			
Ischemic stroke	22/242 (9.1)	16/230 (7.0)	0.50
Intervention because of access site-related ischemia	31/252 (12.3)	55/255 (21.6)	<0.01
Laparotomy because of abdominal compartment	9/243 (3.7)	23/245 (9.4)	0.02
Laparotomy because of bowel ischemia	7/243 (2.9)	11/245 (4.5)	0.48
Other complications			
Hypoxic brain damage	19/179 (10.6)	29/216 (13.4)	0.49
Renal replacement therapy	99/253 (39.1)	148/253 (58.5)	<0.01
Sepsis	44/200 (22.0)	70/251 (27.9)	0.19

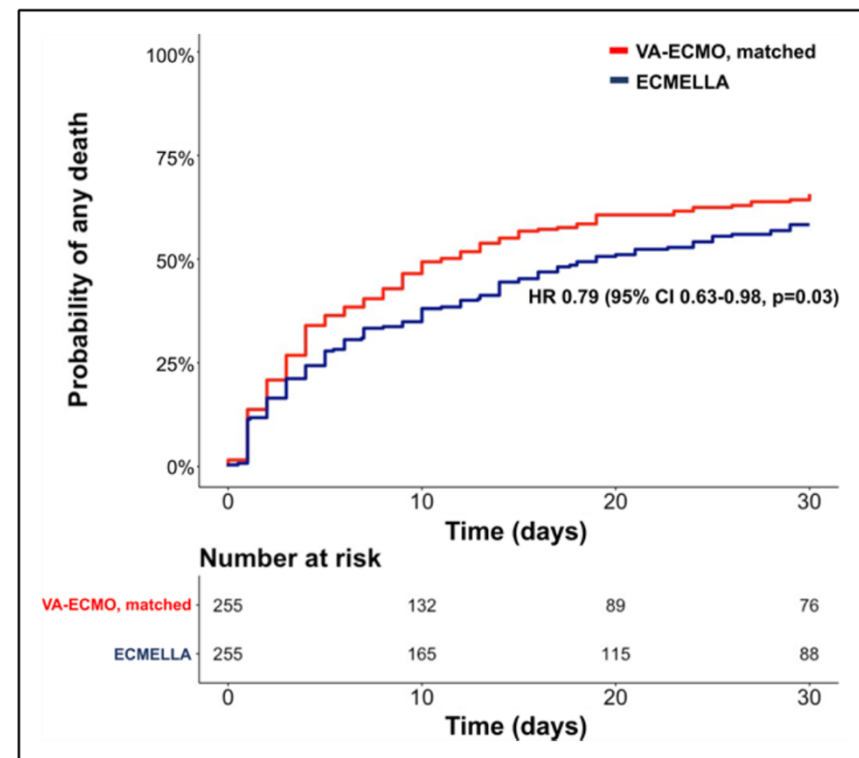

**Figure 2.** Kaplan-Meier curve of the matched study cohort. ECMELLA indicates Impella+extracorporeal membrane oxygenation; HR, hazard ratio; and VA-ECMO, venoarterial extracorporeal membrane oxygenation.

# Decompression of the left atrium during extracorporeal membrane oxygenation using a transseptal cannula incorporated into the circuit\*

Crit Care Med 2006 Vol. 34, No. 10

Ranjit M. Aiyagari, MD; Albert P. Rocchini, MD; Robert T. Remenapp, RN; Joseph N. Graziano, MD

Expérience d'une septotomie atriale percutanée (n=7)

Délai médian 11 heures (6-130 heures)

POG = 31 mmHg (22-45)

Durée de procédure 51 min (42-145)

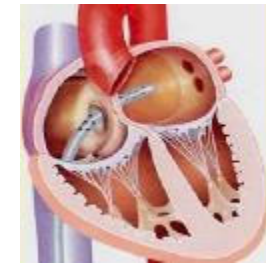

Before



After



## BENEFITS OF PULSATILE ECLS

- Add diastolic pulsatility
- Improve coronary blood flow (diastolic delivery)
- ECG-synchronized pulse flow (pulse delivery in diastole)
  - Avoid conflict between pulse-wave from intrinsic activity of failing heart and ECLS-generated pulse-waves
  - Modulation of ECLS by the patient's own autonomic nervous system

## TEST OF RV FUNCTION IN RESPONSE TO CARDIAC OUTPUT RESTORATION

- Mono-ventricular axial pump
- Without oxygenation
- Restore systemic (and anterograde) blood flow
- Increase venous return (to the right heart)
- In vivo test of RV tolerance if LVAD is planned
- Opportunity for rehabilitation program (axillary insertion)

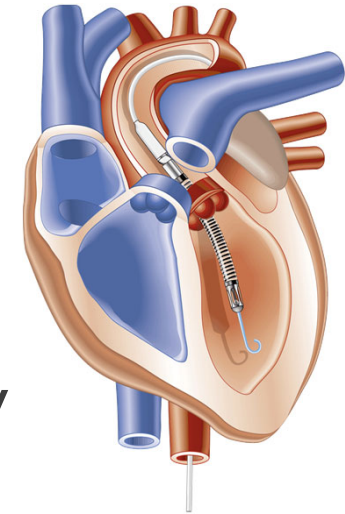

## Maximum level of mobility with axillary deployment of the Impella 5.0 is associated with improved survival

Michele L Esposito, Janelle Jablonski, Allison Kras, Sara Krasney and Navin K Kapur

The International Journal of Artificial  
Organs  
1-4  
© The Author(s) 2018  
Reprints and permissions:  
sagepub.co.uk/journalsPermissions.nav  
DOI: 10.1177/0391398817752575  
journals.sagepub.com/home/ijao  
SAGE

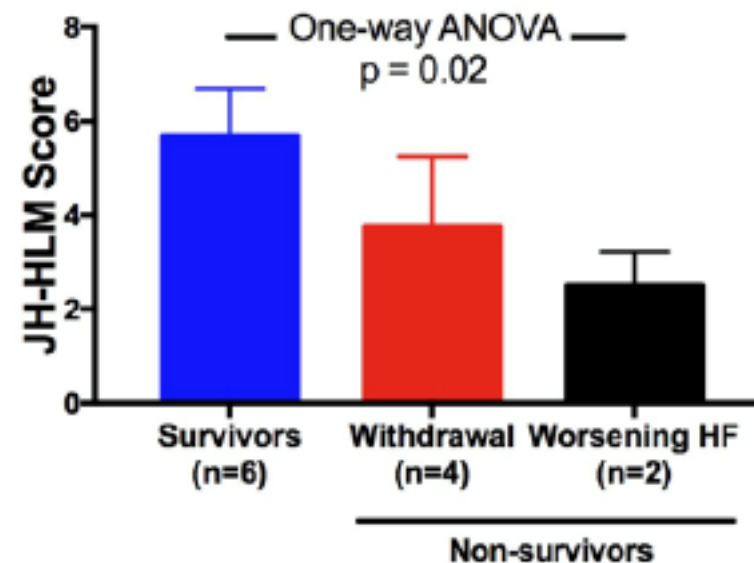

# R-wave ECG synchronisation

- Width of pulsatility 200 msec
- Trigger pulsatile mode (assist frequency 1:1 to 1:2)
- Differential speed value 2000-4000 trm
- Pulsatile must represent at least 20% of cardiac cycle (R-R interval)

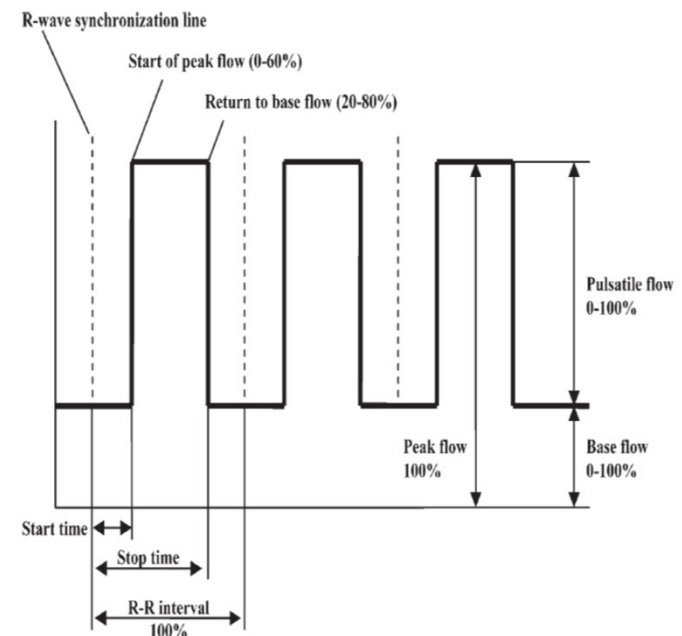
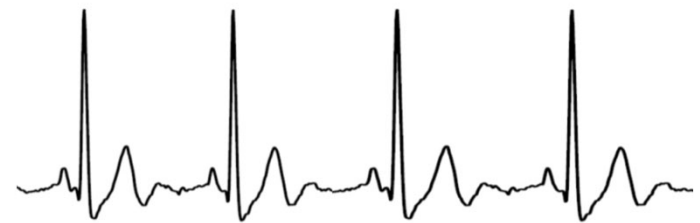

---

$$\text{SEH} = \text{PEE} - \text{PAM}$$

**Débit pulsatile**

Pression équivalente  
d'énergie (PEE)

Surplus  
d'Énergie

Surplus d'Énergie  
Hémodynamique  
(SEH)

**Débit non pulsatile**

Pression artérielle  
moyenne (PAM)

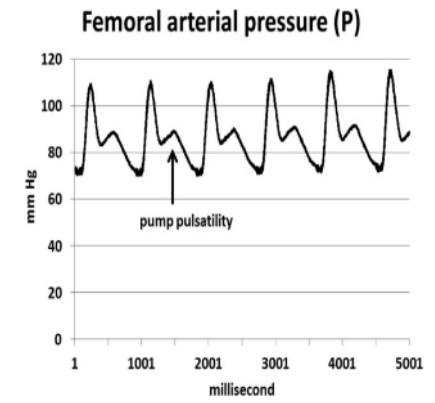
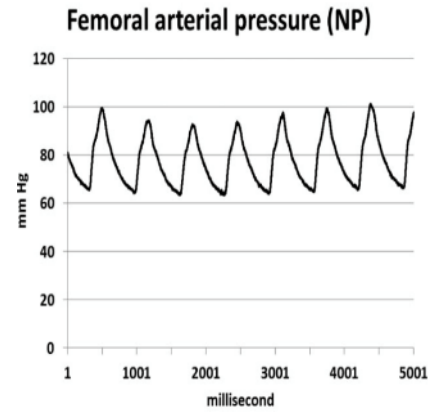
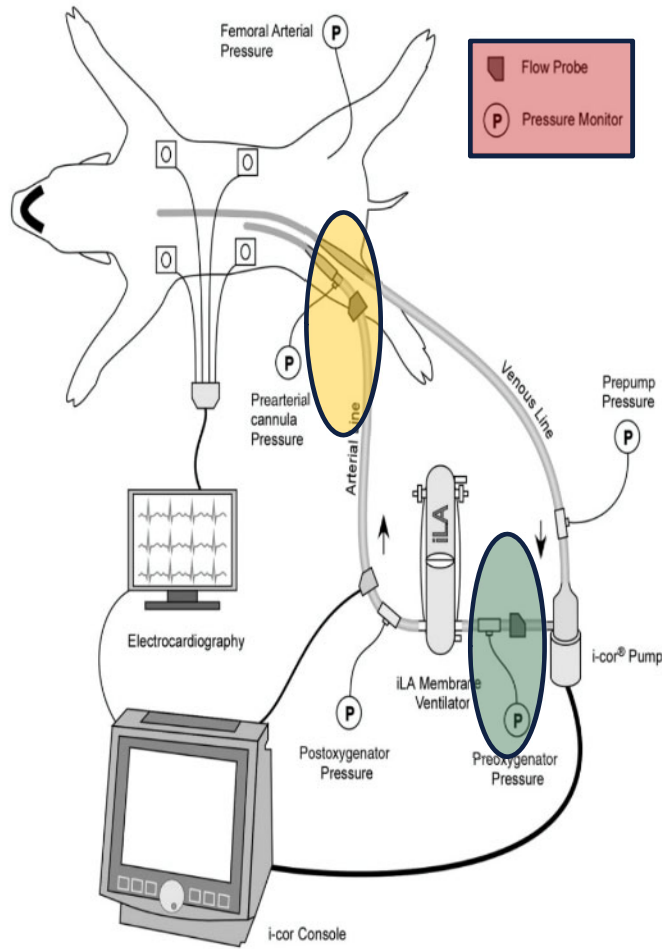

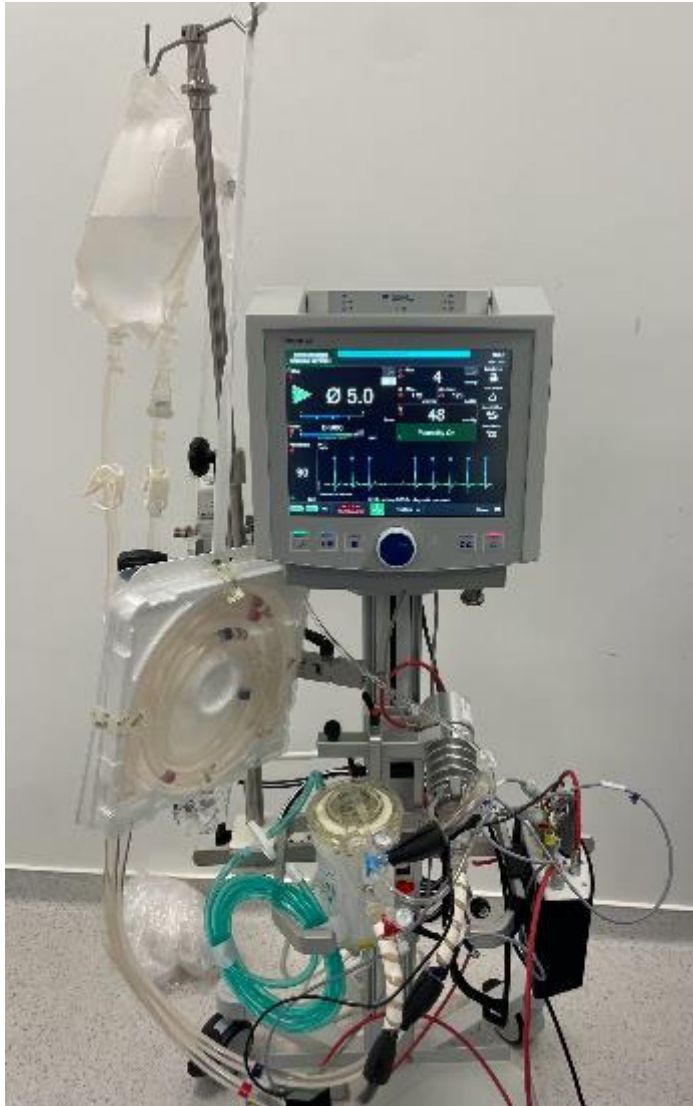

UMR-1054 INSERM  
UNIVERSITY OF BORDEAUX  
INSERM U1044  
UNIVERSITÉ BORDEAUX MÈDECINE



# Efficacy and safety of ECG-synchronized pulsatile extracorporeal membrane oxygenation in the clinical setting: The SynCor Trial

CLINICAL TRIAL

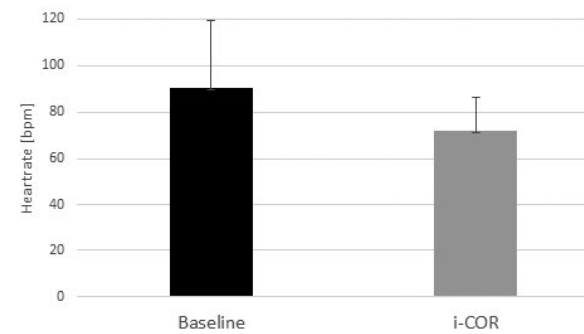
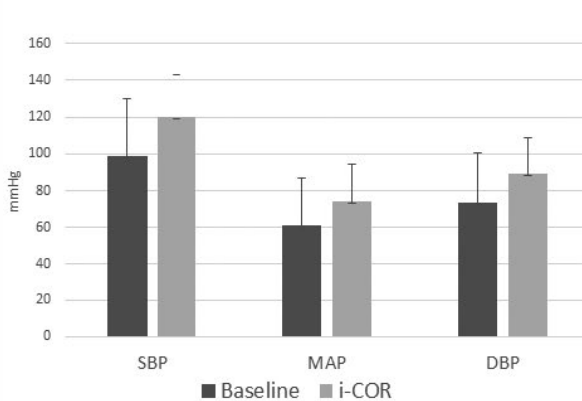
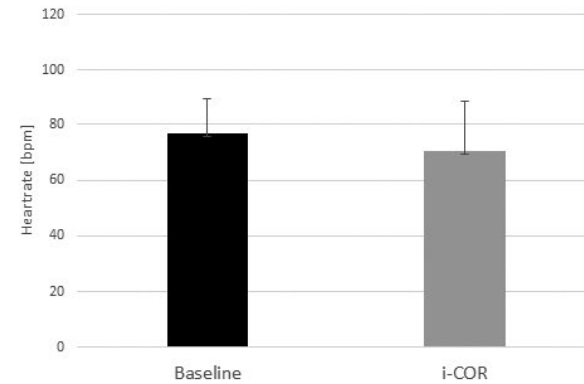
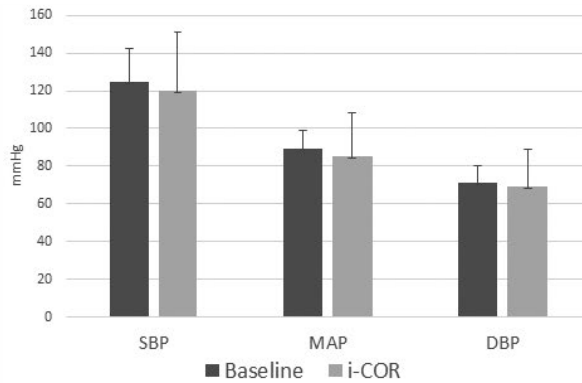

# IMPACT OF VA-ECMO ON CARDIAC (LEFT AND RIGHT) LOADING CONDITIONS

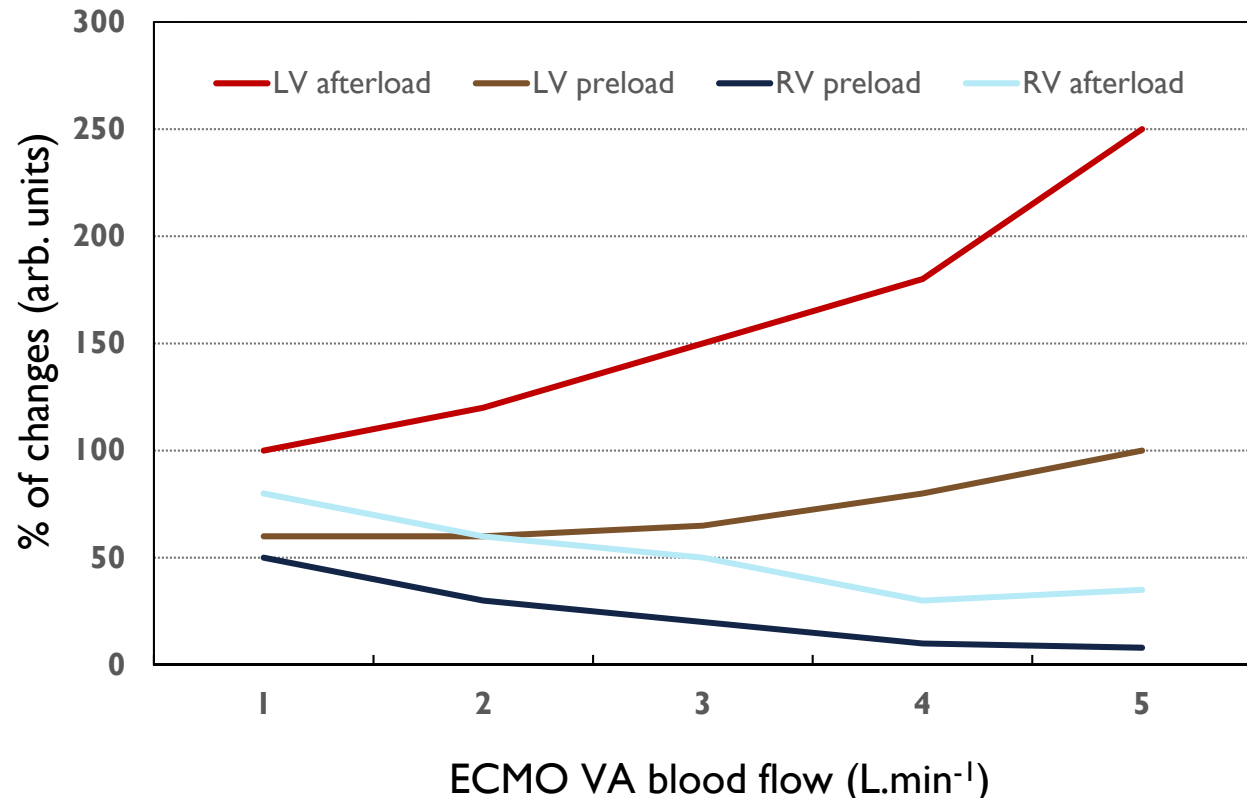
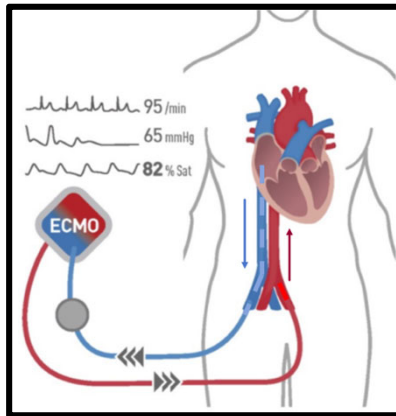

ORIGINAL PRE-CLINICAL SCIENCE

**Changes in hemodynamics, cardiac energetics, and cell signaling pathways induced by veno-arterial extracorporeal membrane oxygenation with or without left ventricular active unloading**

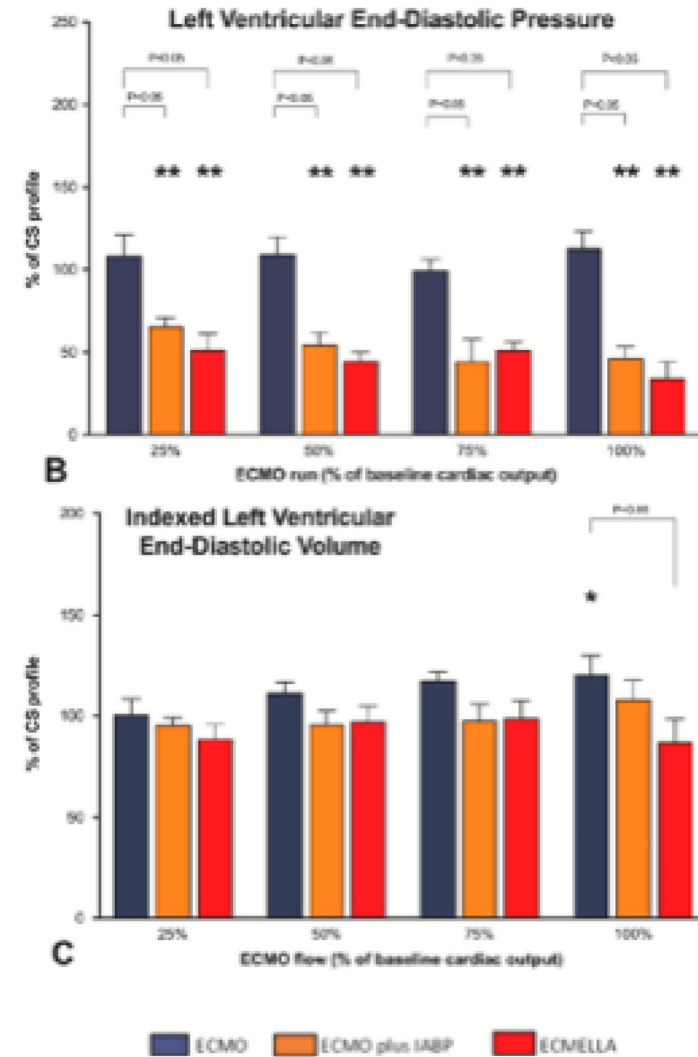
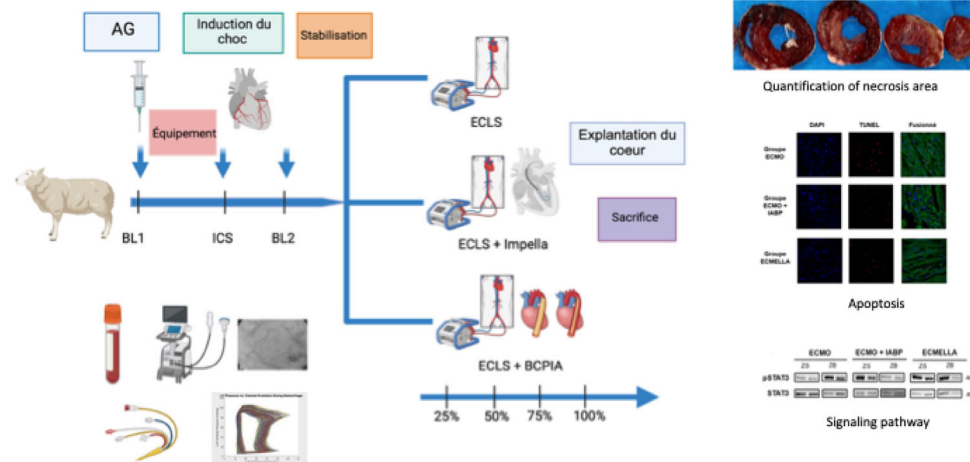

# Cardiac energetics

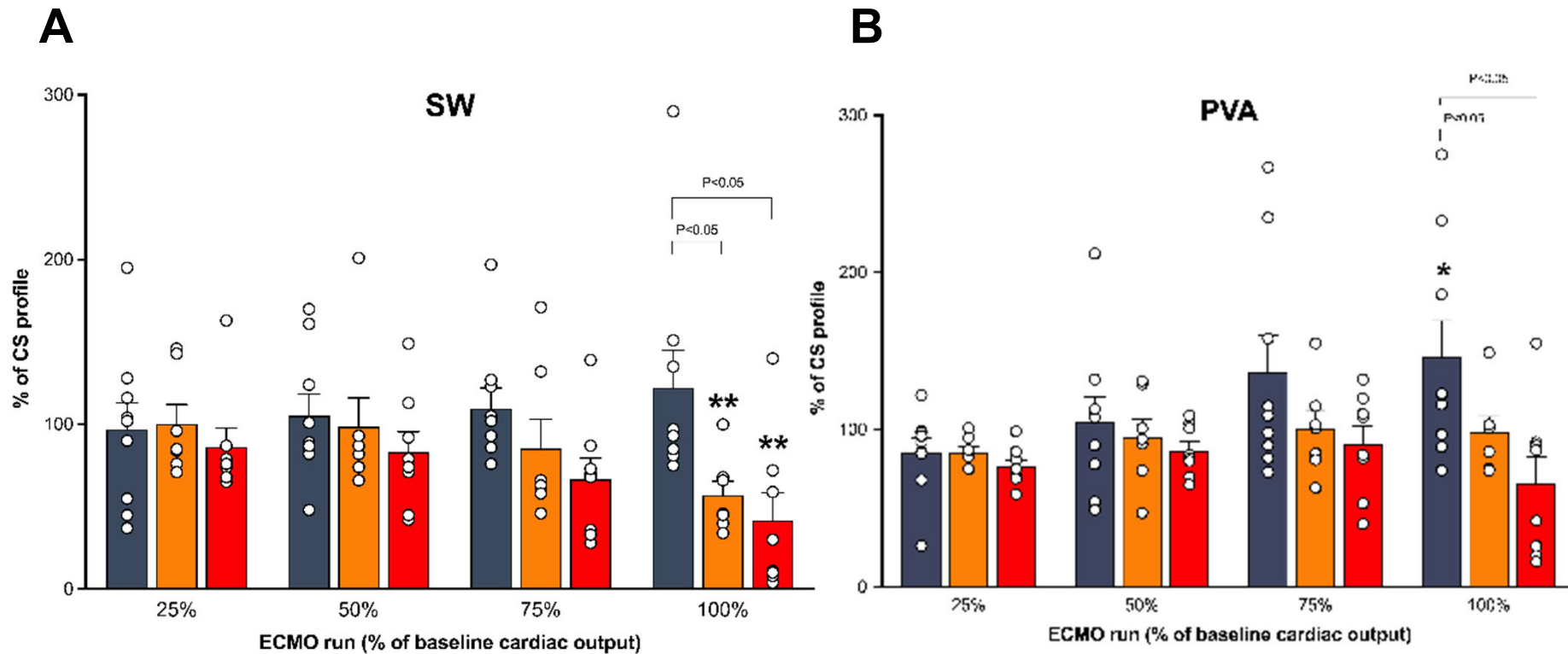

Changes (expressed as % of cardiogenic shock baseline profile) in stroke work (SW) (A) and pressure volume area (PVA) (B) induced by increasing peripheral blood flow of VA-ECMO alone, associated to intra-aortic balloon pump (ECMO plus IABP) or IMPELLA transvalvular micro-axial flow pump (ECMELLA). The ECMO blood flow was increased from 25% to 100% of the baseline cardiac output before cardiogenic shock. Open circles represent individual pigs and bars/whiskers group mean  $\pm$  SEM. \*:  $P < 0.05$  and \*\*:  $P < 0.01$  for intra-group comparison versus cardiogenic shock baseline profile by using two-way analysis of variance (ANOVA) with repeated measures followed by Tukey-Kramer's multiple comparisons post hoc test

ECMO
  ECMO plus IABP
  ECMELLA

# Cardioprotective myocyte cardiac signaling pathway

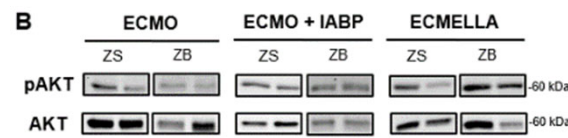
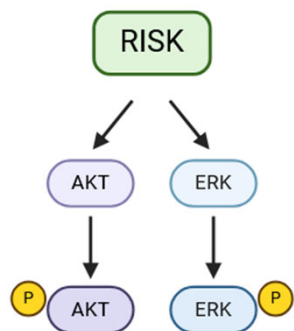
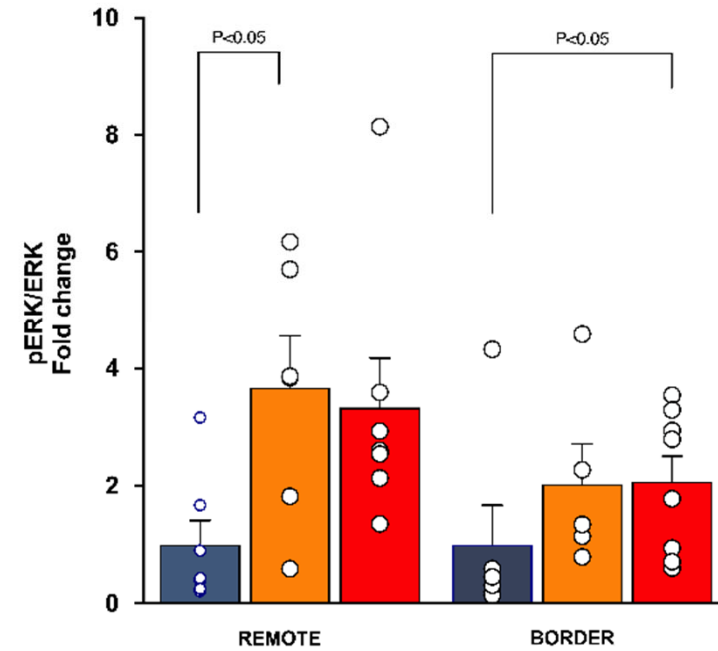
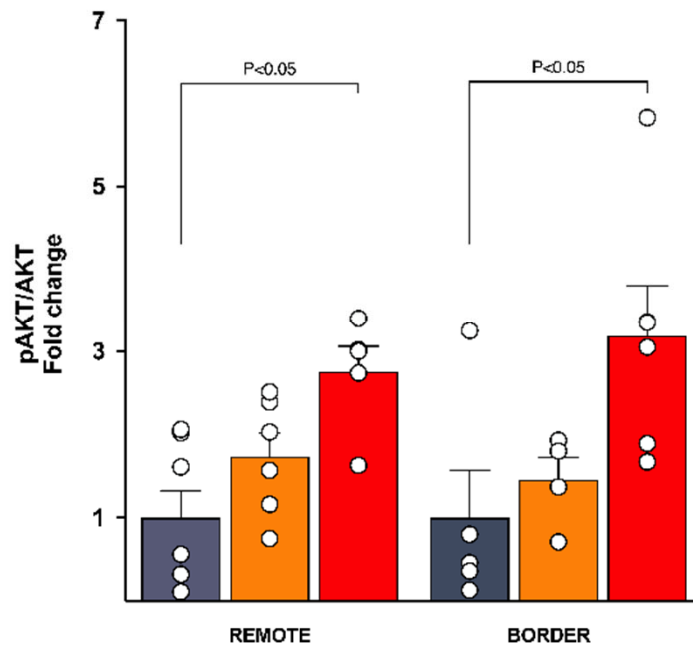

■ ECMO

■ ECMO plus IABP

■ ECMELLA

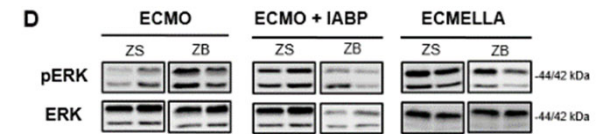

## CARDIAC HAEMODYNAMIC AND VA-ECMO



- Decrease RV loading conditions
- Blood flow dependent increase in LV loading conditions (pre and after load)
- Blood flow dependent increase in total parietal stress
- Blood flow dependent increase in myocardial work and thus  $MvO_2$
- Decreased coronary blood flow

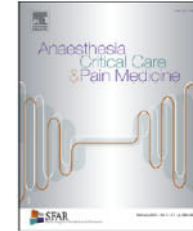

Editorial

ExtraCorporeal Life support for refractory cardiogenic shock:  
“An efficient system support of peripheral organs more than real  
ventricular assist device...”

Alexandre Ouattara<sup>a,b,\*</sup>, Alain Rémy<sup>b</sup>, Astrid Quessard<sup>b</sup>

<sup>a</sup>Université Bordeaux, Inserm, UMR 1034, biology of cardiovascular diseases, 33600 Pessac, France

<sup>b</sup>CHU Bordeaux, department of anaesthesia and critical care, Magellan Medico-Surgical Centre, 33000 Bordeaux, France

# Broncho-pulmonary shunt...

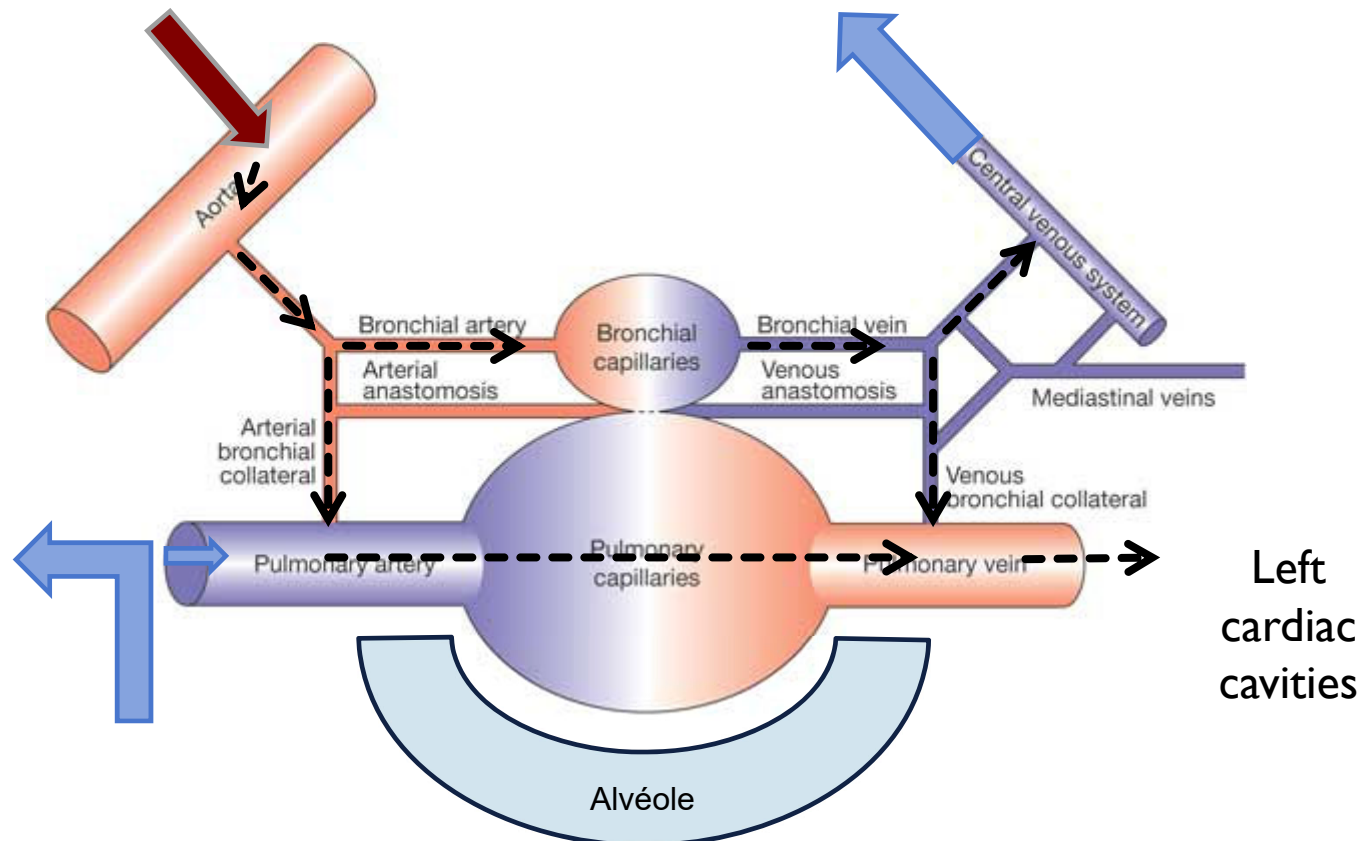

# Concomitant implantation of Impella<sup>®</sup> on top of veno-arterial extracorporeal membrane oxygenation may improve survival of patients with cardiogenic shock

Pappalardo F et al. Eur J Heart Failure 2016

Retrospective multicenter trial (n=2) including **Propensity Score adjustment**  
ECLS alone versus ECLS + IMPELLA (2.5 or CP)

**Table 1** Comparison of baseline characteristics between patients treated with veno-arterial extracorporeal membrane oxygenation (ECMO) and Impella and patients treated with veno-arterial ECMO only in the original unmatched population (n = 157)

Parameter	Total (n = 157)	ECMO + Impella (n = 34)	ECMO (n = 123)	P-value	Absolute standardized difference <sup>a</sup>
Age, years	55 (46–64)	54 (47–66)	55 (45–64)	0.9	0.0217
Males, n (%)	130 (83)	28 (82)	102 (83)	0.9	0.0263
CPR, n (%)	100 (64)	14 (41)	86 (70)	0.002	0.6101
STEMI, n (%)	85 (54)	15 (44)	70 (57)	0.2	0.2622
PCI, n (%)	56 (36)	16 (47)	40 (33)	0.10	0.2887
pH	7.23 (6.98–7.39)	7.36 (7.08–7.41)	7.16 (6.95–7.37)	0.02	0.5087
Lactates, mmol/L	9.55 (4.40–15.35)	8.96 (3.10–16.25)	10.26 (4.97–15.24)	0.4	0.1173
Concomitant IABP, n (%)	54 (34)	8 (24)	46 (37)	0.10	0.2852

CPR, cardiopulmonary resuscitation; IABP, intra-aortic balloon pump; STEMI, ST-segment elevation myocardial infarction.

<sup>a</sup>0–0.2 small effect size; 0.2–0.5 medium effect size; 0.5–0.8 large effect size; 0.8–1 very large effect size.

# Concomitant implantation of Impella<sup>®</sup> on top of veno-arterial extracorporeal membrane oxygenation may improve survival of patients with cardiogenic shock

Pappalardo F et al. Eur J Heart Failure 2016

Retrospective multicenter trial (n=2) including **Propensity Score adjustment**  
 ECLS alone versus ECLS + IMPELLA (2.5 or CP)

**Table 3** Comparison of major outcomes between patients treated with veno-arterial extracorporeal membrane oxygenation (ECMO) and Impella and patients treated with veno-arterial ECMO only in the propensity score matching sample (n = 63)

Parameter	Total (n = 63)	ECMO + Impella (n = 21)	ECMO (n = 42)	P-value
Hospital mortality, n (%)	41 (65)	10 (48)	31 (74)	0.04
Bridge to next therapy or recovery, n (%)	28 (44)	13 (62)	15 (36)	0.048
Waning from MCS, n (%)	26 (41)	10 (48)	16 (38)	0.047
Bridge to recovery, n (%)	19 (30)	8 (38)	11 (26)	0.3
Bridge to VAD, n (%)	8 (13)	4 (19)	4 (9.5)	0.5
Bridge to cardiac transplantation, n (%)	0	0	0	
Duration of ECMO, h	120 (36–234)	148 (72–239)	73.5 (29–217)	0.2
Duration of MV, h	93 (29–228)	163 (90–228)	48 (17–265)	0.04
CVVH, n (%)	18 (29)	10 (48)	8 (19)	0.02
Haemolysis, n (%)	30 (48)	16 (76)	14 (33)	0.004
Major bleeding, n (%)	20 (32)	8 (38)	12 (29)	0.6
Minor bleeding, n (%)	14 (22)	4 (19)	10 (24)	0.8
LVEF at weaning, %	45.5 (30–55)	52.5 (47–55.5)	37.5 (25–50)	0.13

CVVH, continuous veno-venous haemofiltration; MCS, mechanical circulatory support; MV, mechanical ventilation; VAD, ventricular assist device.

## WHICH BEST STRATEGY?



Complementary (and multidisciplinary)  
strategies...

# Short-term mechanical circulatory support

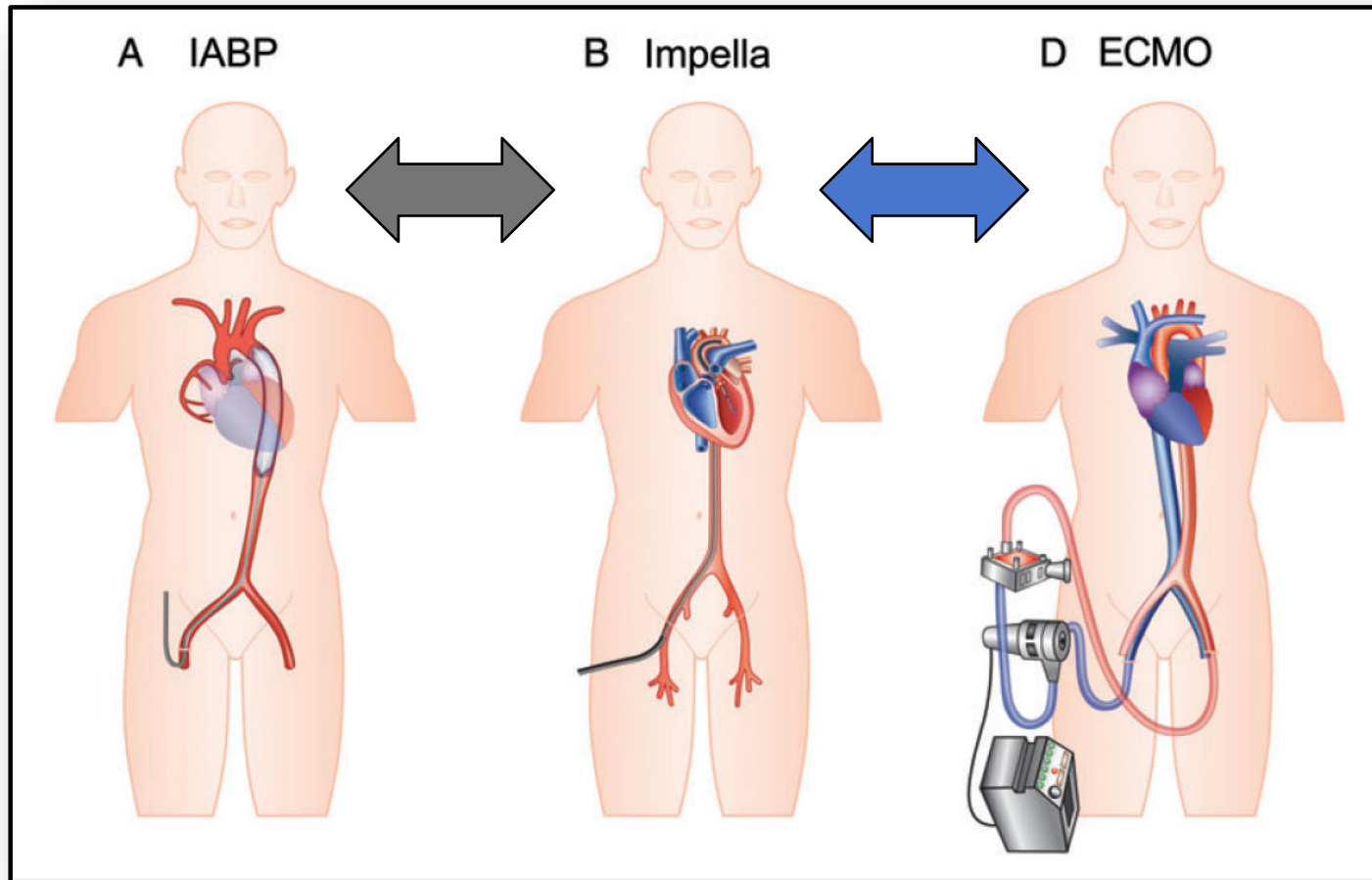

## STMCS activity over the study period

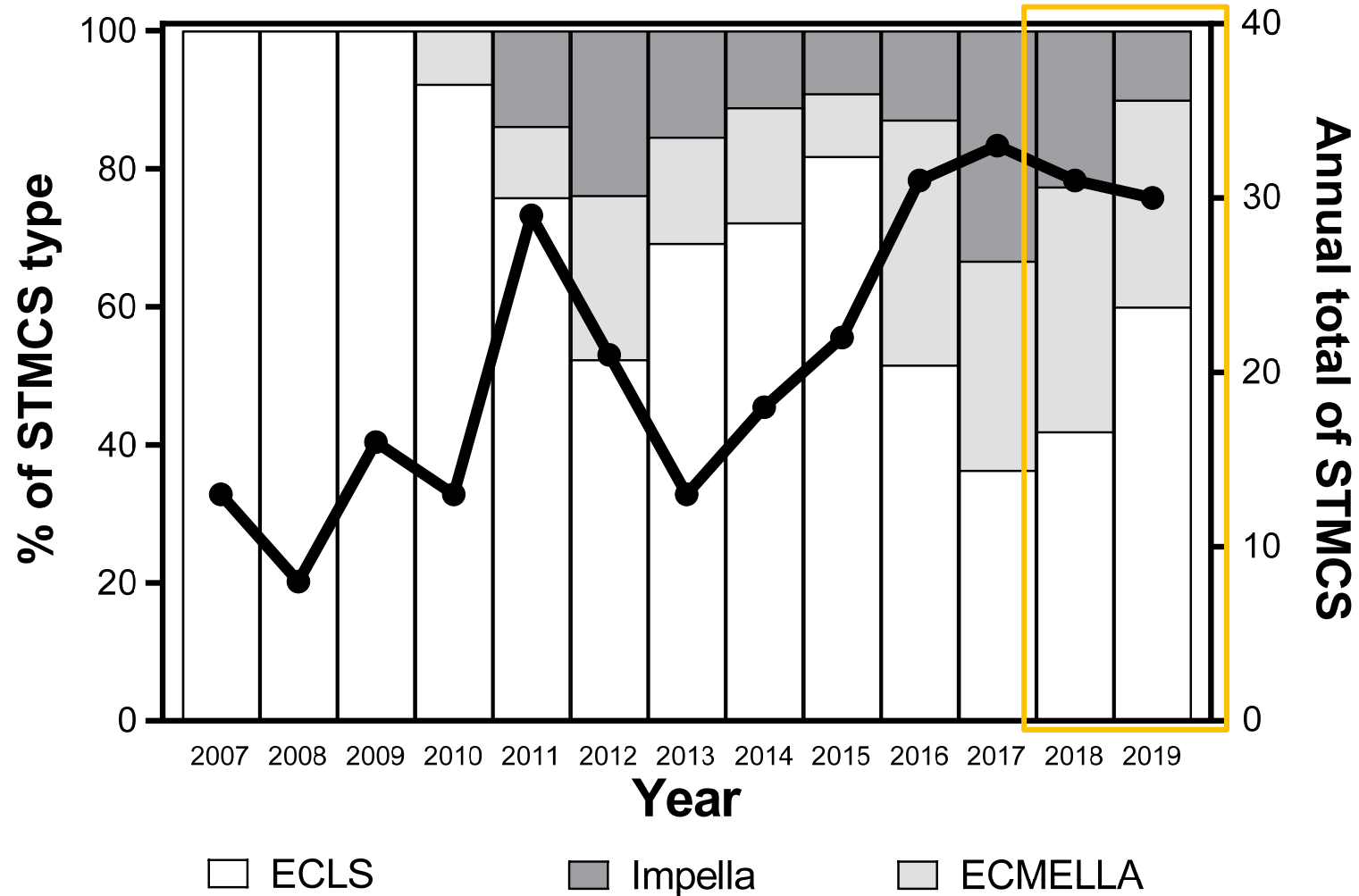

Henrion FX et al. (in submission)

# Mechanical Pre-Conditioning With Acute Circulatory Support Before Reperfusion Limits Infarct Size in Acute Myocardial Infarction

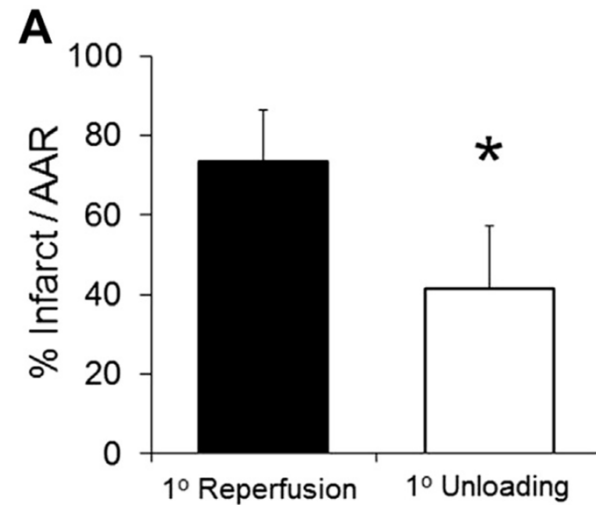
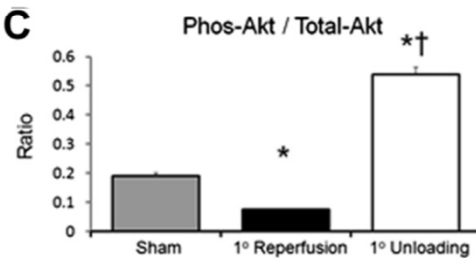
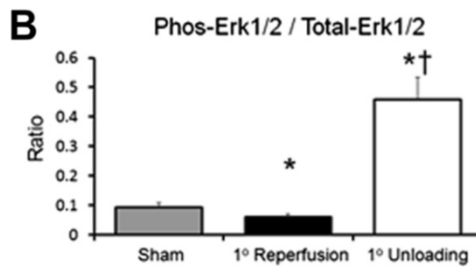
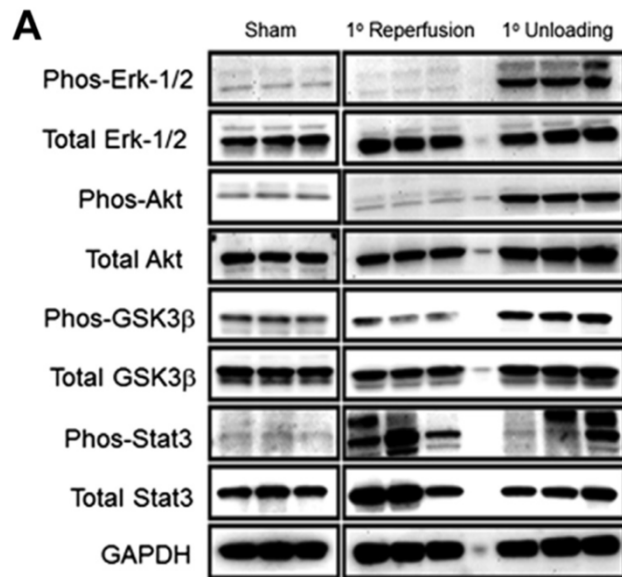
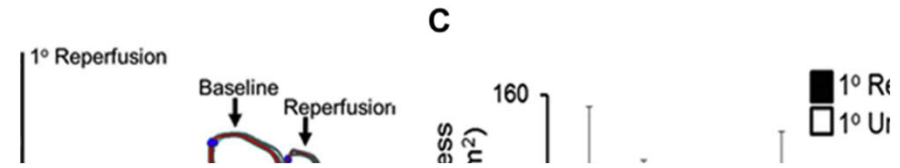
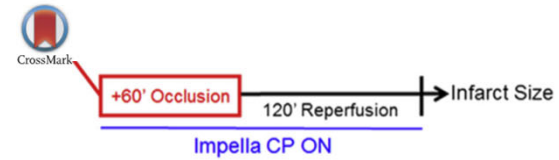

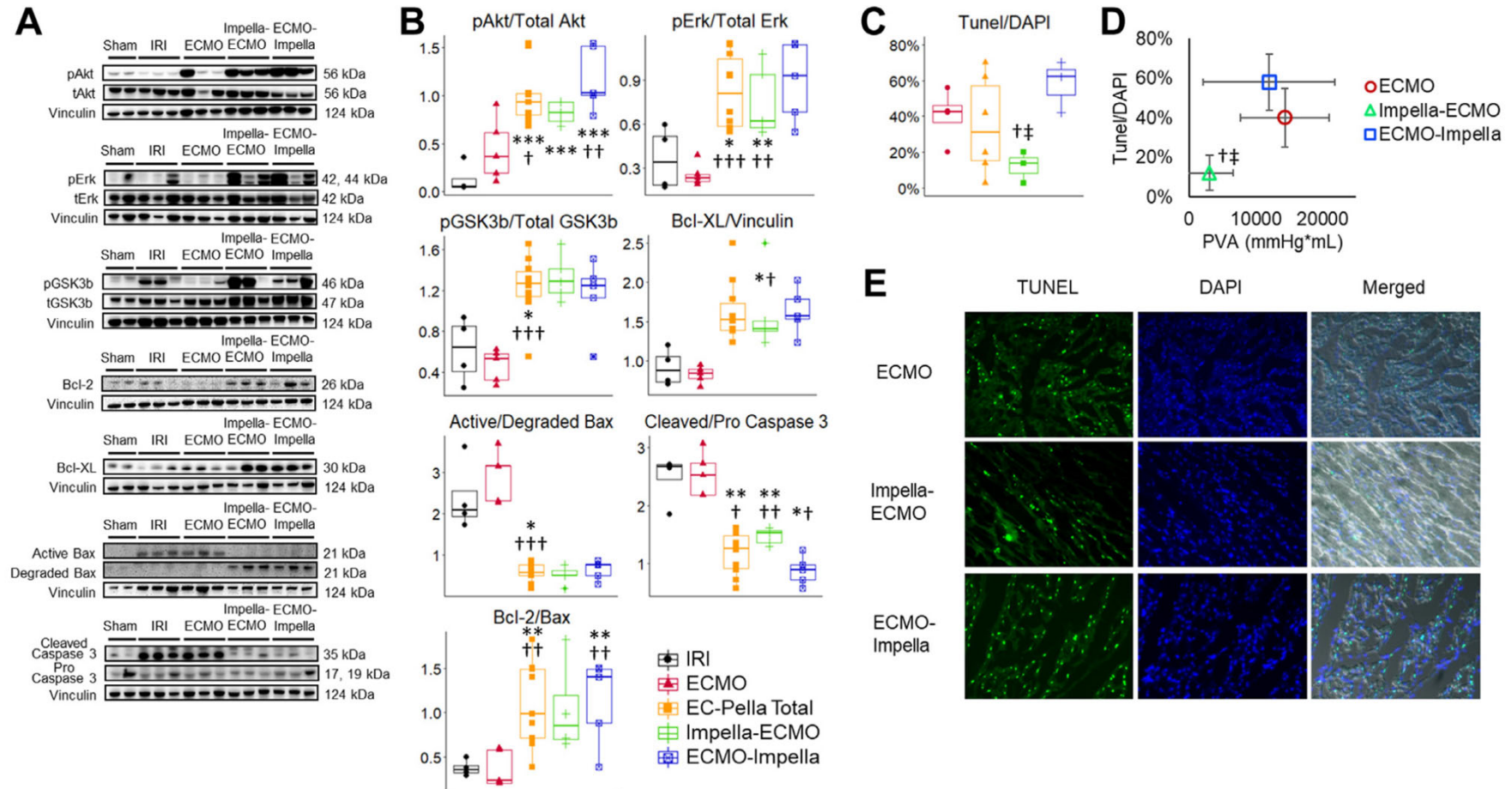
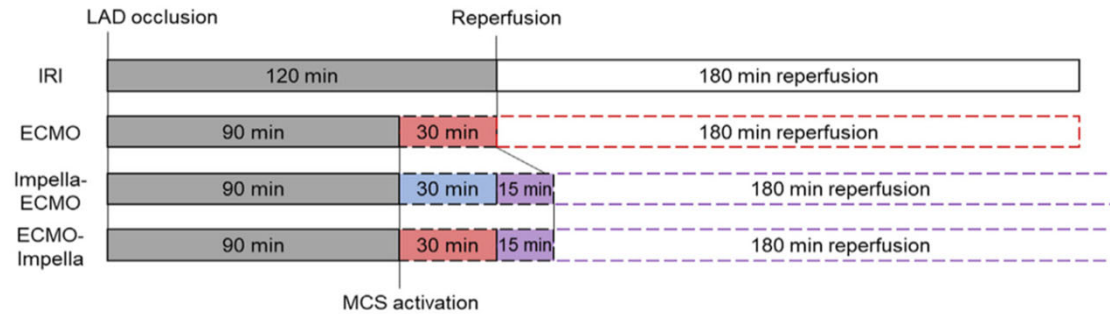

# Survival signaling pathways

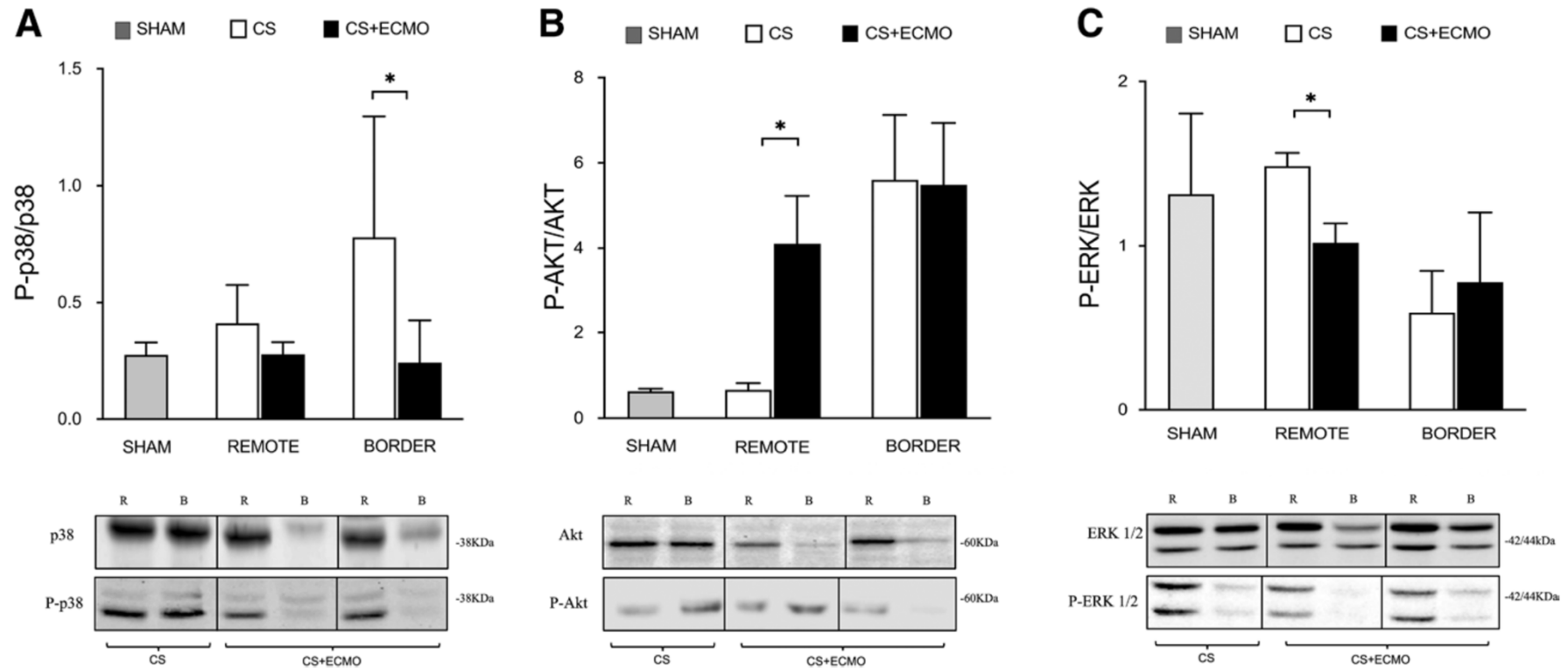

# WHAT IS THE IMPACT OF ASSOCIATION OF ECMO TO MECHANICAL LV UNLOADING?

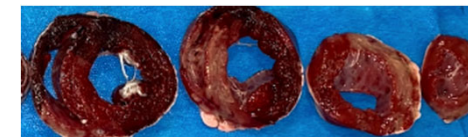
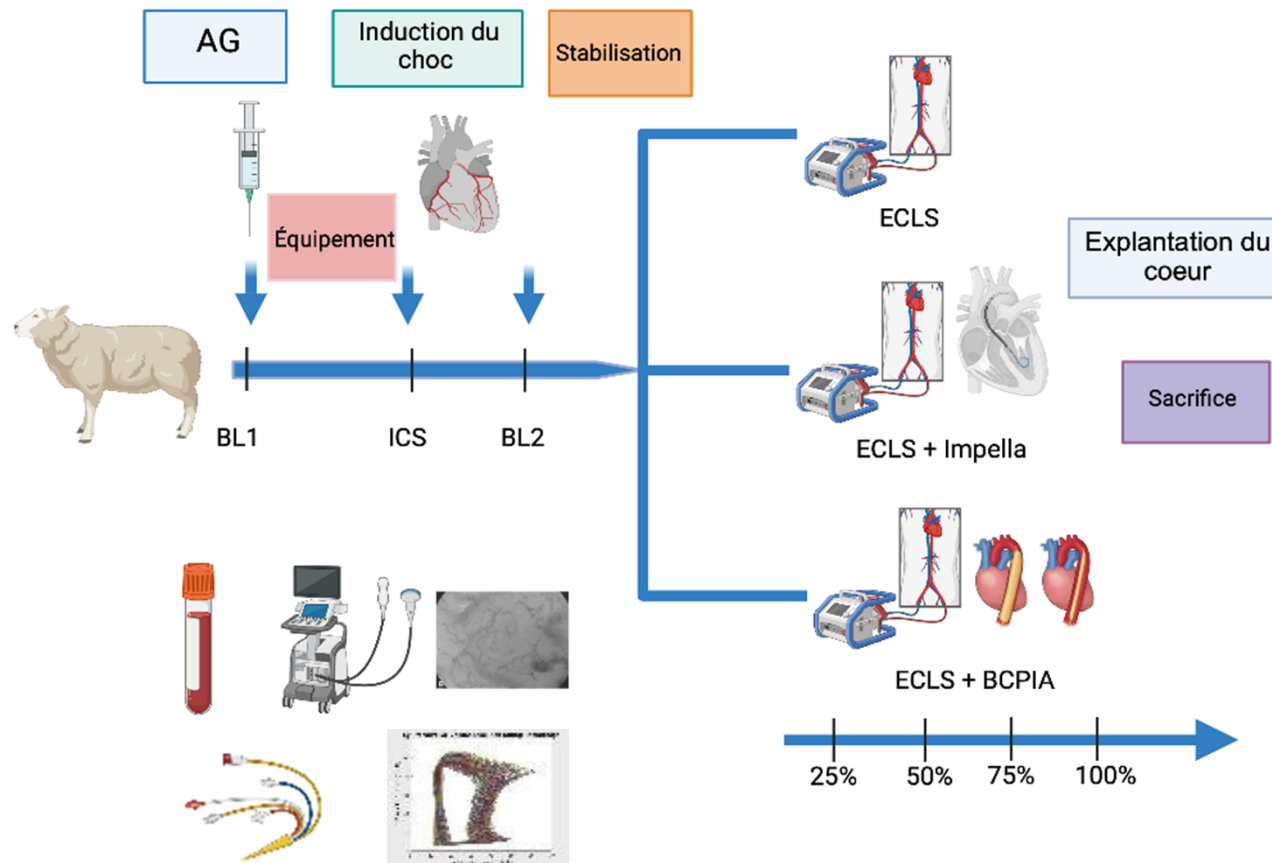

Quantification of necrosis area

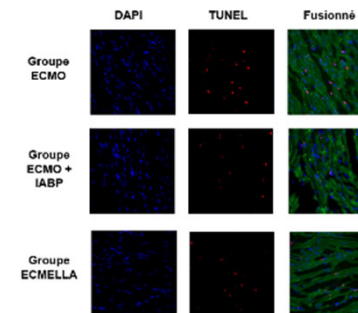

Apoptosis

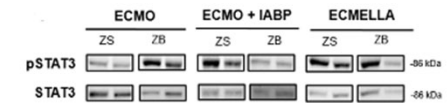

Signaling pathway

# Systemic haemodynamic

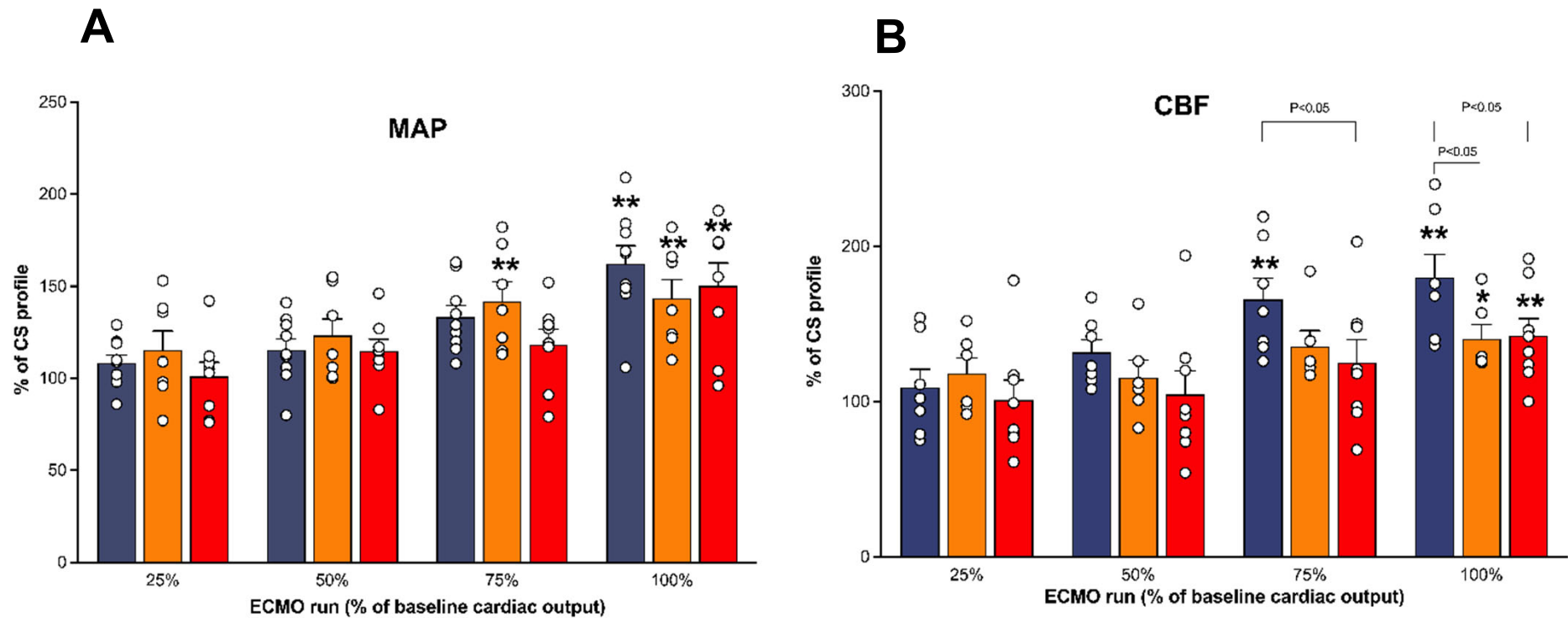

Changes (expressed as % of cardiogenic shock baseline profile) in mean arterial pressure (MAP **(A)** and carotid blood flow (CBF **(B)**) induced by increasing blood flow of peripheral VA-ECMO alone, associated to intra-aortic balloon pump (ECMO+IABP) or to IMPELLA transvalvular micro-axial flow pump (ECMELLA). The blood flow of the ECMO was increased from 25% to 100% of the baseline cardiac output before cardiogenic shock. Open circles represent individual pigs and bars/whiskers group mean  $\pm$  SEM. \*:  $P < 0.05$  and \*\* $P < 0.01$  for intra-group comparison versus cardiogenic shock baseline profile and P value shown versus ECMO alone at each level of blood flow by using two-way analysis of variance (ANOVA) with repeated measures followed by Tukey-Kramer's multiple comparisons post hoc test

ECMO
  ECMO plus IABP
  ECMELLA

# Cardiac loading conditions

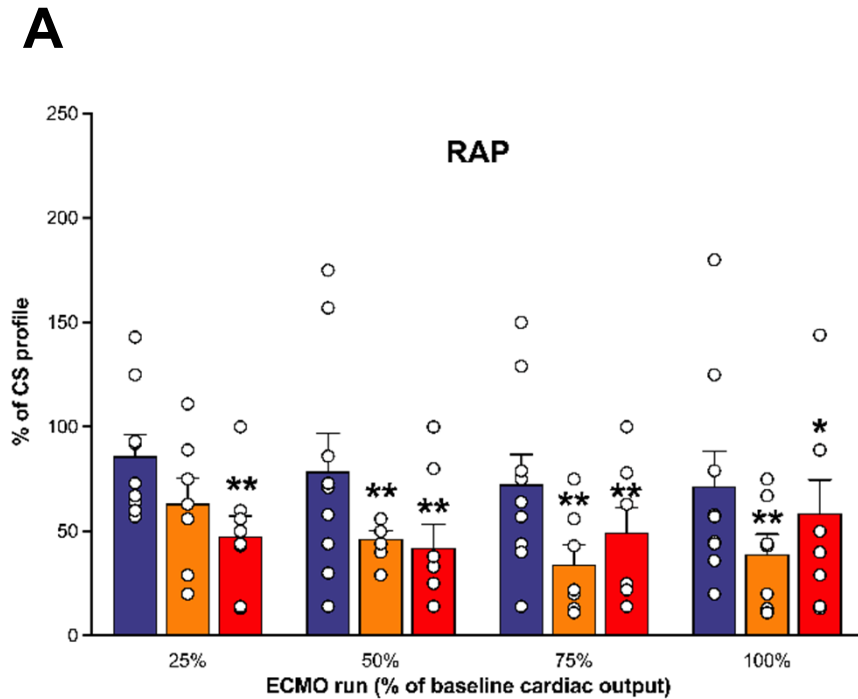

Changes (expressed as % of cardiogenic shock baseline profile) in right atrial pressure (RAP) (A), mean pulmonary arterial pressure (mPAP) (B) and left ventricular end-diastolic pressure (LVEDP) (C) induced by increasing blood flow of peripheral VA-ECMO alone, associated to intra-aortic balloon pump (ECMO plus IABP) or IMPELLA transvalvular micro-axial flow pump (ECMELLA). The ECMO blood flow was increased from 25% to 100% of the baseline cardiac output before cardiogenic shock. Open circles represent individual pigs and bars/whiskers group mean  $\pm$  SEM. \*:  $P < 0.05$  and \*\* $P < 0.01$  for intra-group comparison versus cardiogenic shock baseline profile and P value shown versus ECMO alone at each level of blood flow by using two-way analysis of variance (ANOVA) with repeated measures followed by Tukey-Kramer's multiple comparisons post hoc test

■ ECMO   ■ ECMO plus IABP   ■ ECMELLA

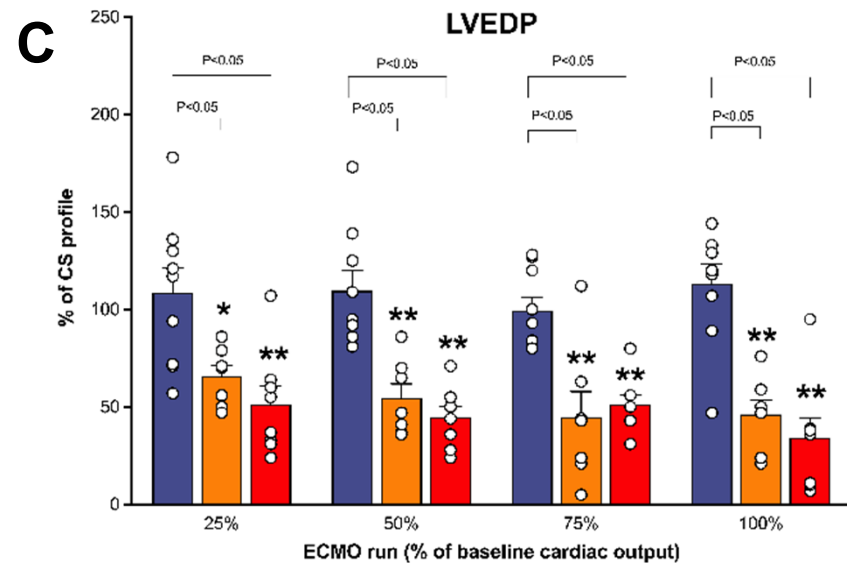
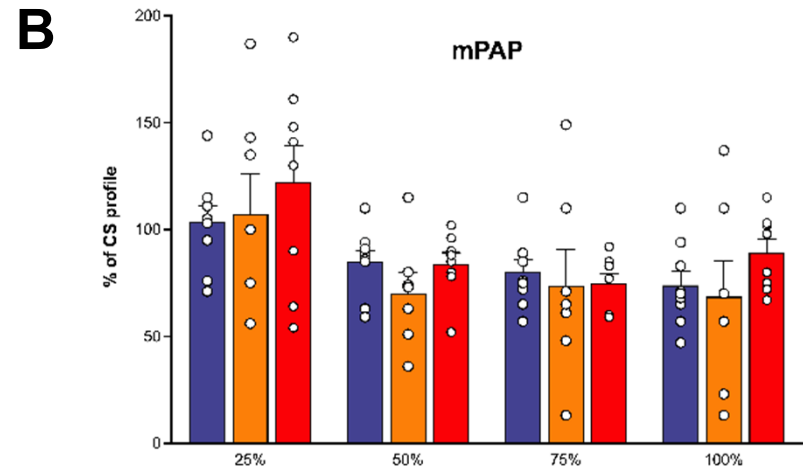

# Cardiac loading conditions

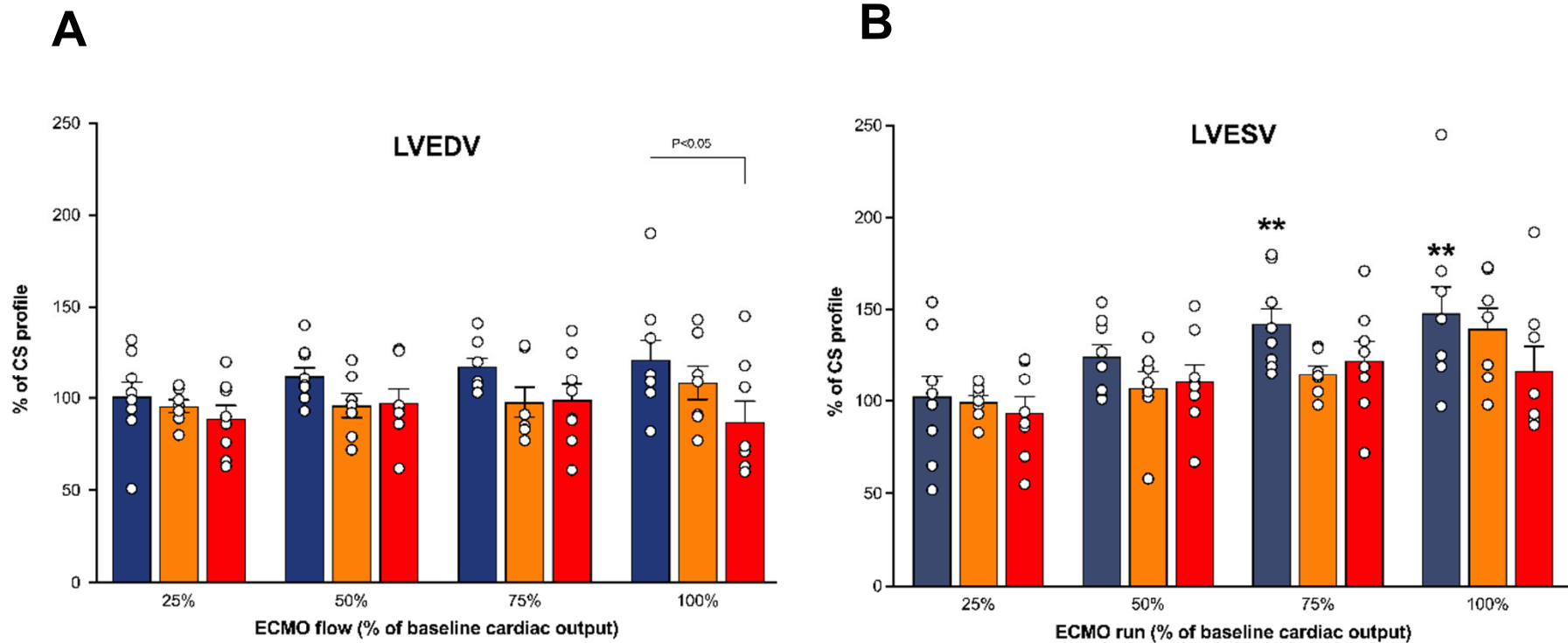

Changes (expressed as % of cardiogenic shock baseline profile) in Left ventricular end-diastolic volume (LVEDV) (A) and Left ventricular end-systolic volume (LVESV) (B) induced by increasing blood flow of peripheral VA-ECMO alone, associated to intra-aortic balloon pump (ECMO plus IABP) or IMPELLA transvalvular micro-axial flow pump (ECMELLA). The ECMO blood flow was increased from 25% to 100% of the baseline cardiac output before cardiogenic shock. Open circles represent individual pigs and bars/whiskers group mean  $\pm$  SEM. \*:  $P < 0.05$  and \*\* $P < 0.01$  for intra-group comparison versus cardiogenic shock baseline profile and P value shown versus ECMO alone at each level of blood flow by using two-way analysis of variance (ANOVA) with repeated measures followed by Tukey-Kramer's multiple comparisons post hoc test

ECMO ECMO plus IABP ECMELLA

# Cardiac loading conditions

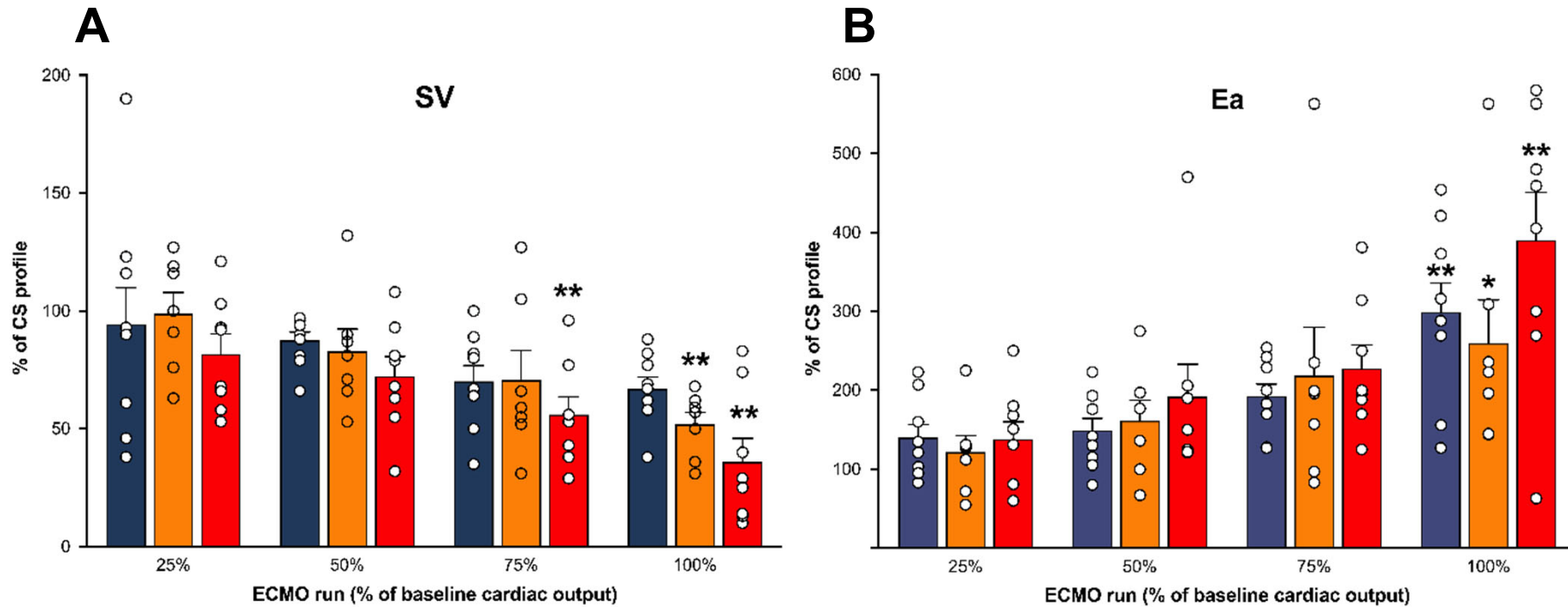

Changes (expressed as % of cardiogenic shock baseline profile) in stroke volume (SV) (A) and arterial elastance (Ea) (B) induced by increasing peripheral blood flow of VA-ECMO alone, associated to intra-aortic balloon pump (ECMO plus IABP) or IMPELLA transvalvular micro-axial flow pump (ECMELLA). The ECMO blood flow was increased from 25% to 100% of the baseline cardiac output before cardiogenic shock. Open circles represent individual pigs and bars/whiskers group mean  $\pm$  SEM. \*:  $P < 0.05$  and \*\* $P < 0.01$  for intra-group comparison versus cardiogenic shock baseline profile by using two-way analysis of variance (ANOVA) with repeated measures followed by Tukey-Kramer's multiple comparisons post hoc test

ECMO
  ECMO plus IABP
  ECMELLA

# Conjunctival microcirculation

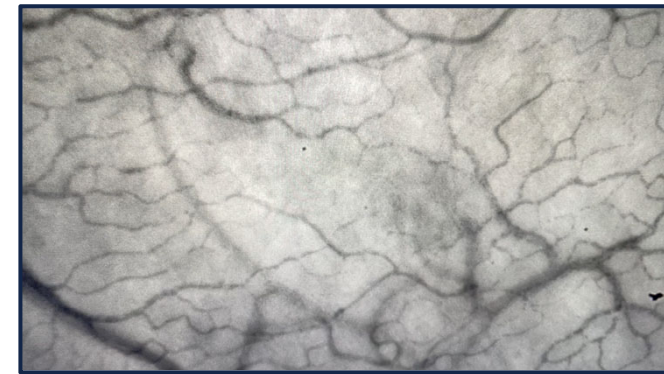

■ ECMO      ■ ECMELLA      ■ ECMO plus IABP

### Total Vessel Density

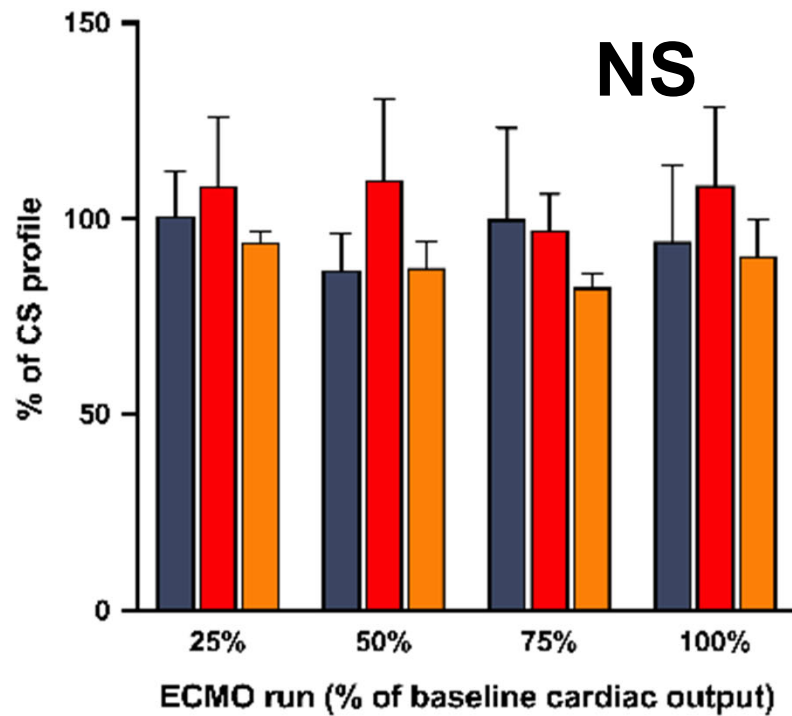

### Perfused Vessel Density

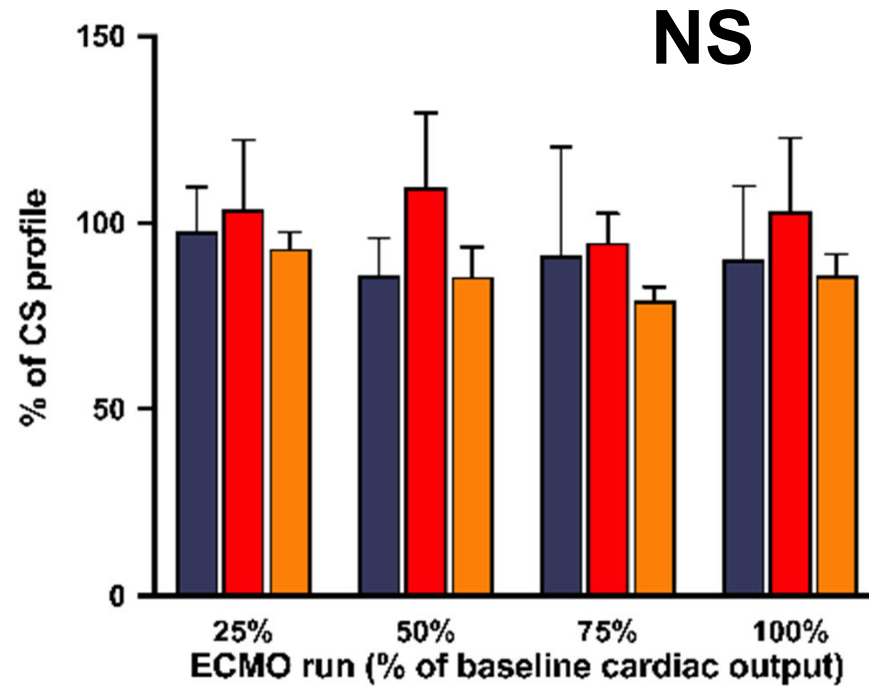

# APOPTOSIS



A. SHAM

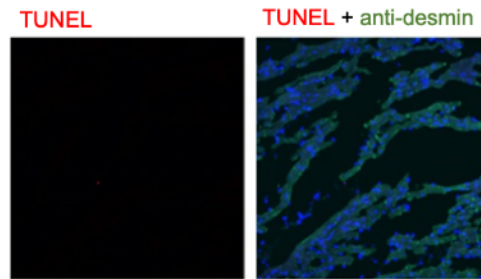

B. CS

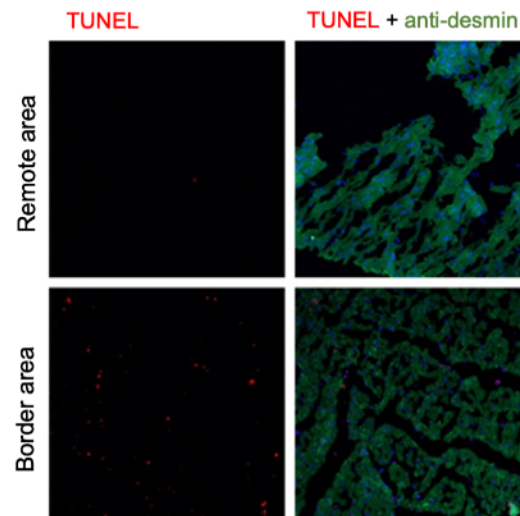

C. CS+ECMO

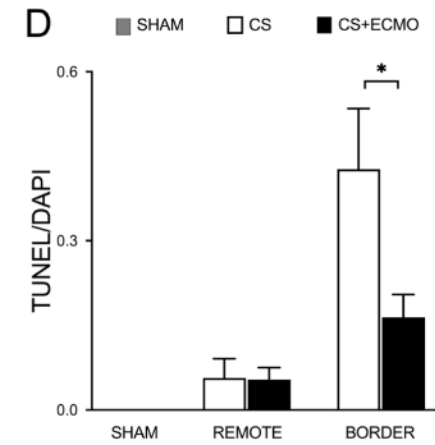
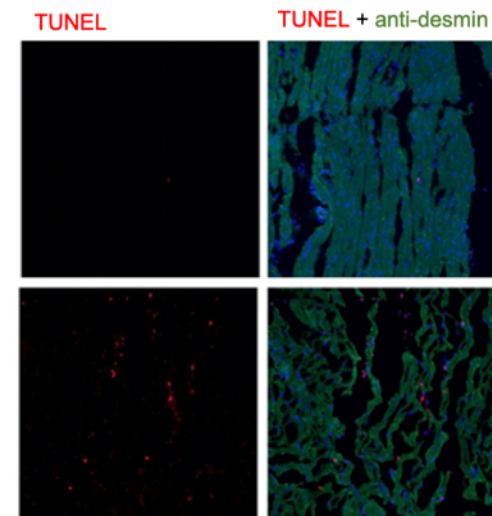

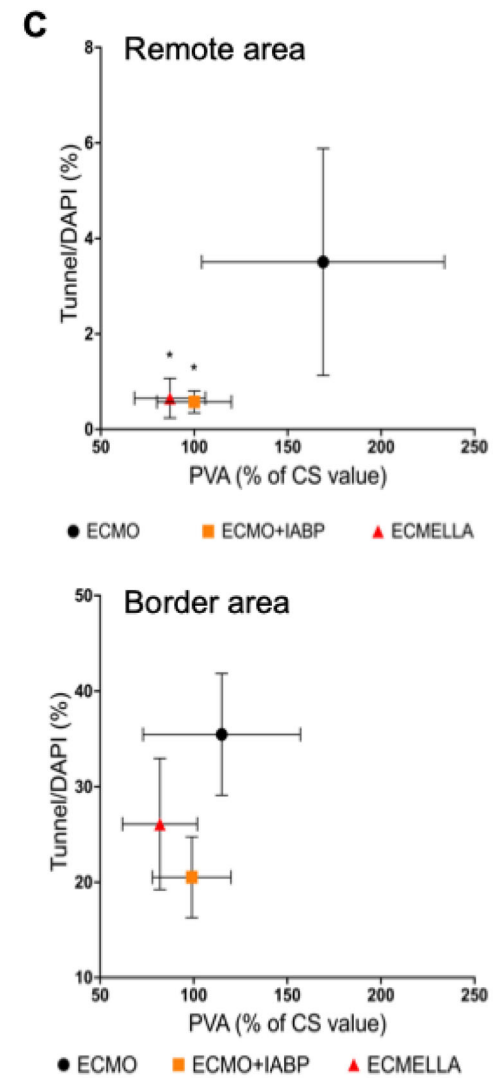
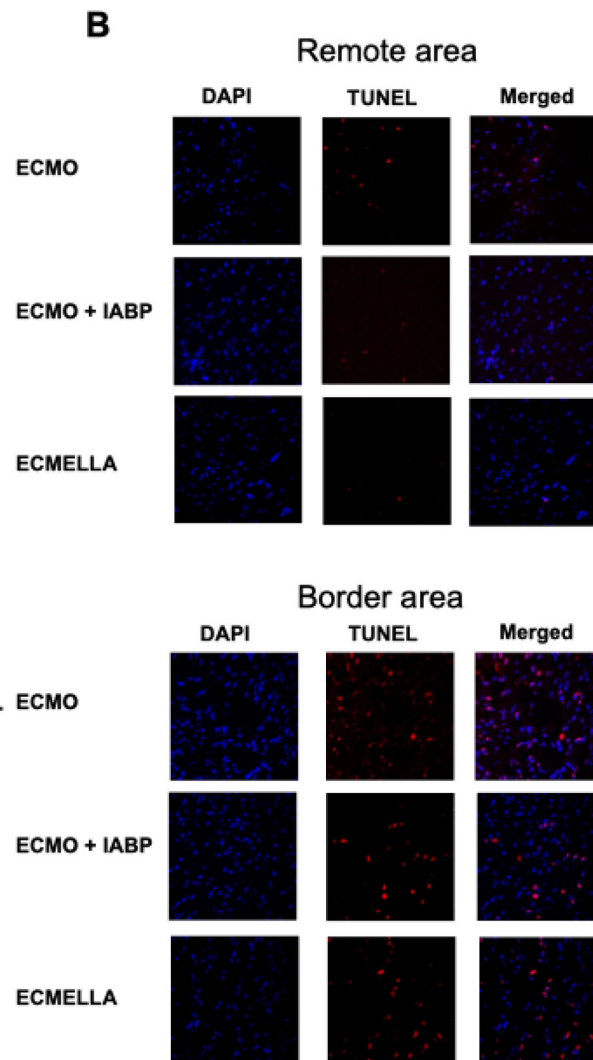
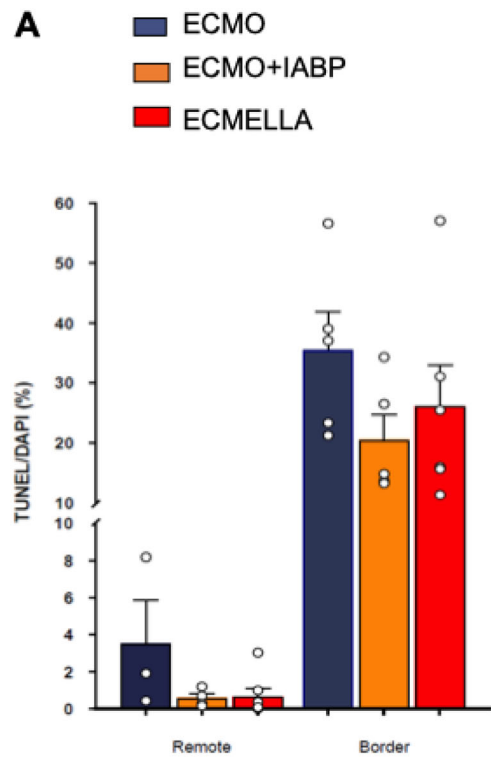

# ECMO and IABP

## Myocardial oxygen balance

**TABLE 1.** The hemodynamic effect of IABP during partial ECLS support

	Baseline	Central configuration		Peripheral configuration	
		ECLS	ECLS + IABP	ECLS	ECLS + IABP
HR (bpm)	100 (10)	105 (10) <i>P</i> = 0.176	105 (10)* <i>P</i> = 0.043	95 (7)* <i>P</i> = 0.028	95 (7) <i>P</i> = 1.00
Plv,peak (mm Hg)	65 (16)	75 (25) <i>P</i> = 0.091	72 (25)* <i>P</i> = 0.043	72 (29) <i>P</i> = 0.176	67 (28)* <i>P</i> = 0.018
Pasc (mm Hg)	52 (10)	68 (24)* <i>P</i> = 0.018	72 (23)* <i>P</i> = 0.018	66 (26)* <i>P</i> = 0.018	67 (27)*** <i>P</i> = 0.866
LVO (L/min)	4.1 (1.0)	3.1 (0.9) <i>P</i> = 0.091	3.0 (1.0) <i>P</i> = 0.237	2.5 (1.1)* <i>P</i> = 0.018	2.7 (1.1)*** <i>P</i> = 0.018
Qcor (mL/min)	110 (63)	104 (68) <i>P</i> = 0.735	114 (76)* <i>P</i> = 0.018	101 (59) <i>P</i> = 0.499	106 (62)* <i>P</i> = 0.043
EW (J/beat)	0.33 (0.13)	0.30 (0.13) <i>P</i> = 0.462	0.27 (0.12)* <i>P</i> = 0.017	0.24 (0.11)* <i>P</i> = 0.018	0.24 (0.14) <i>P</i> = 0.394
PE (J/beat)	0.30 (0.30)	0.35 (0.28) <i>P</i> = 0.107	0.32 (0.26)* <i>P</i> = 0.027	0.37 (0.33)* <i>P</i> = 0.028	0.30 (0.25)* <i>P</i> = 0.027
PVA (J/beat)	0.63 (0.41)	0.65 (0.39) <i>P</i> = 0.735	0.59 (0.36)* <i>P</i> = 0.018	0.61 (0.36) <i>P</i> = 0.600	0.54 (0.37)* <i>P</i> = 0.028
Qcor/(PVA·HR) (mL/J)	2.04 (1.32)	1.78 (1.23) <i>P</i> = 0.063	2.15 (1.52) <i>P</i> = 0.018	2.38 (1.99) <i>P</i> = 0.499	2.92 (2.65)* <i>P</i> = 0.018
TTI (Pa·s)	16 (6)	20 (8)* <i>P</i> = 0.018	18 (8)* <i>P</i> = 0.028	20 (10)* <i>P</i> = 0.018	18 (10)* <i>P</i> = 0.018
DPTI (Pa·s)	14 (5)	19 (8)* <i>P</i> = 0.018	22 (8)* <i>P</i> = 0.018	22 (10)* <i>P</i> = 0.018	24 (11)*** <i>P</i> = 0.018
DPTI/TTI (%)	90 (19)	100 (20) <i>P</i> = 0.310	127 (29)* <i>P</i> = 0.018	110 (23) <i>P</i> = 0.063	136 (27)* <i>P</i> = 0.018

# Watershed phenomena during extracorporeal life support and their clinical impact: a systematic in vitro investigation

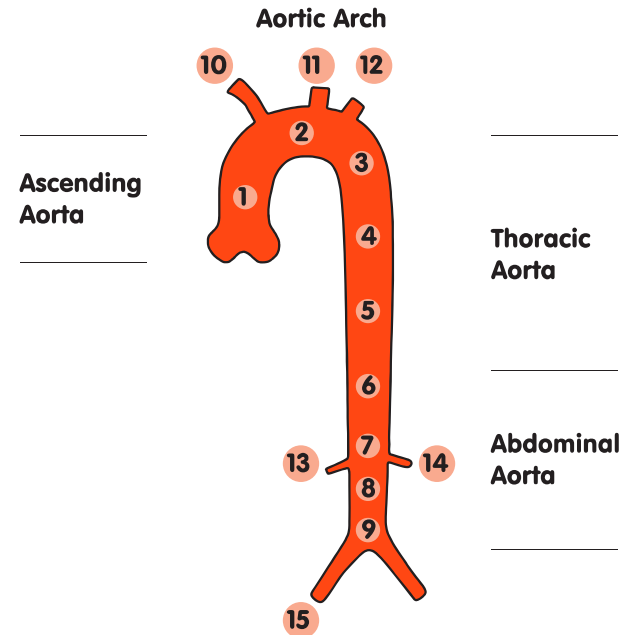
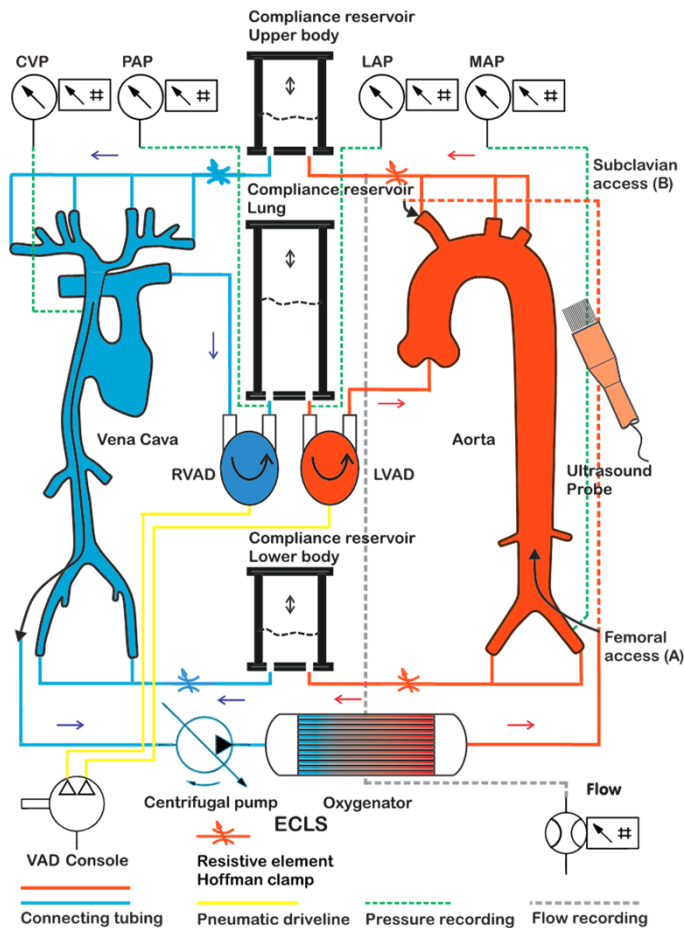

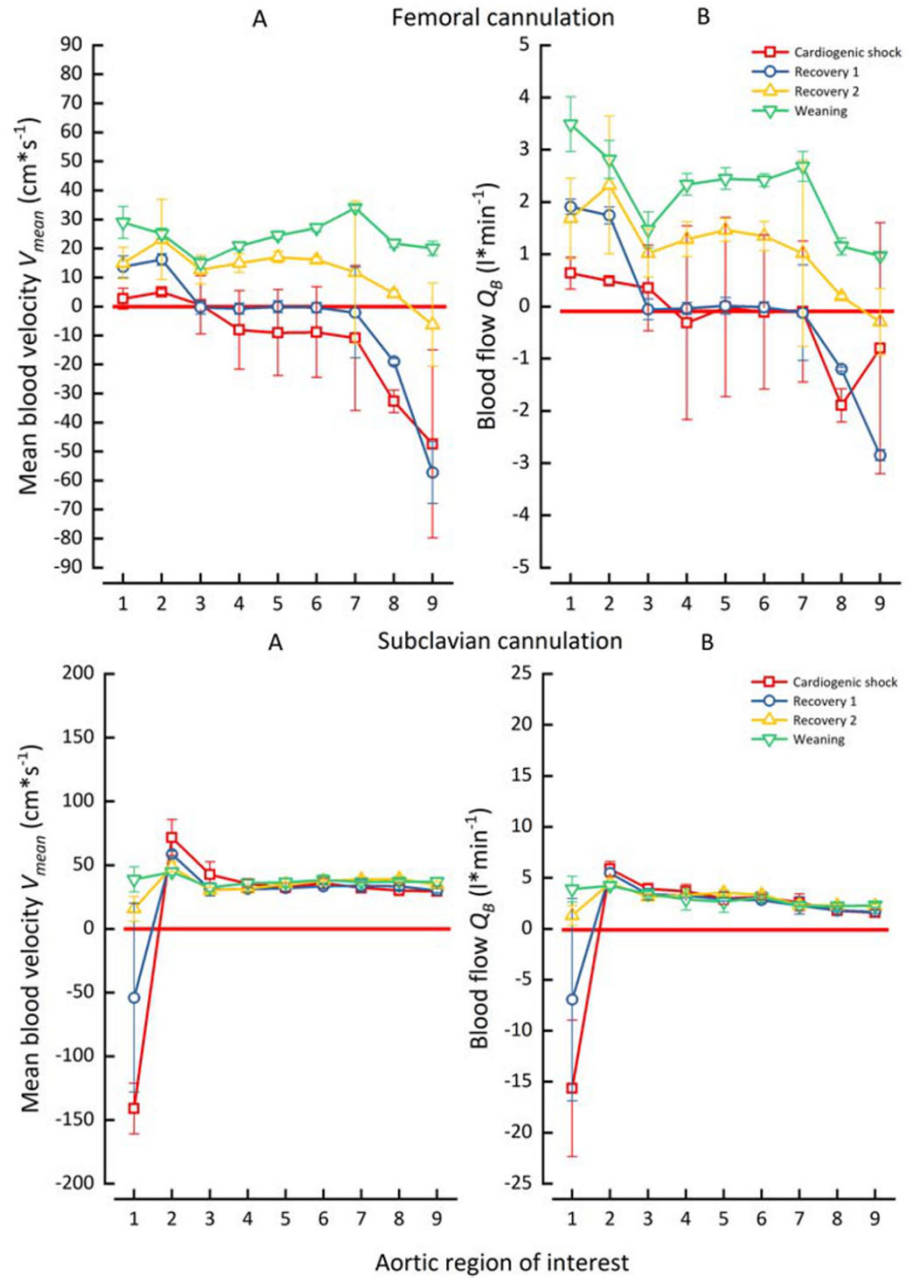
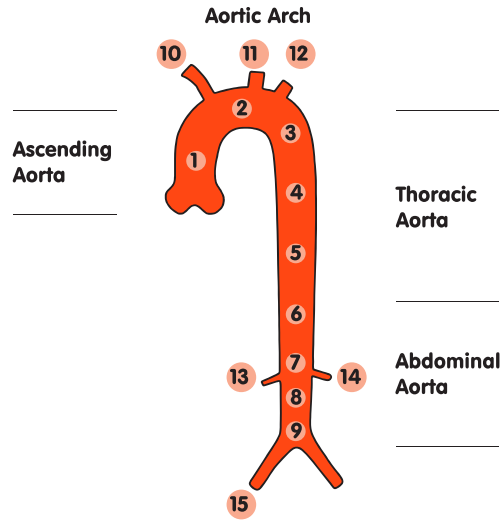

# Refractory cardiogenic shock and ARDS

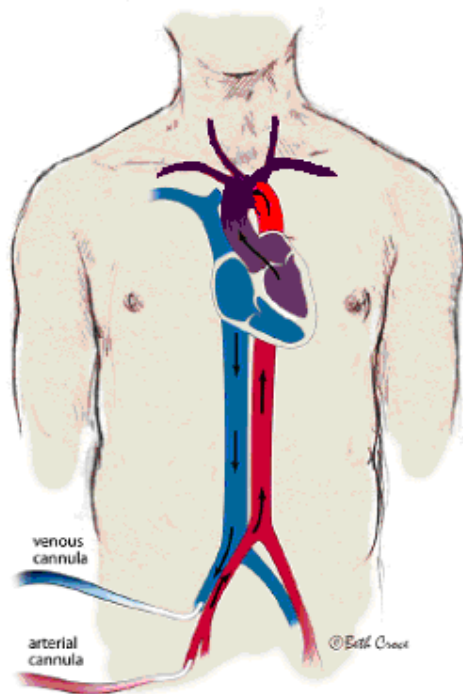

- Persistence of arterial pulmonary blood flow
- Loading of left atrium with hypoxic blood
- Perfusion of supra-aortic and coronary vessels
- Interface between hypoxemic blood and normoxic from ECLS depends:
  - Residual ventricular contractility
  - Level of supply by ECLS
  - Importance of pulmonary disease
- Arlequin Syndrome+++
- **Perform blood gas analysis from right artery radial +++++**

# SOLUTIONS

- Centralisation
  - Heavy technology
  - Bleeding risk

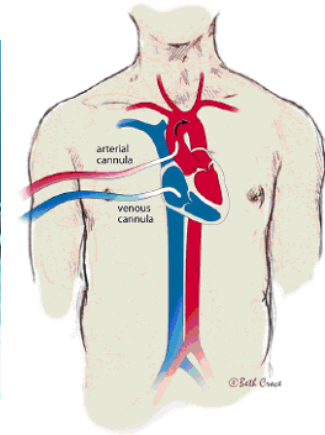

- Axillary cannulation

*Stulak JM et al. Seminars Cardiothorac Vasc Anesth 2009;13:176-82*





### Advantages

- Anterograde flow
- Cephalic perfusion

### Disadvantages

- Upper limb ischemia



Case report

Moisan M et al. *Ann Fr Anesth Réanim* 2013;32:e71-75

Pulmonary alveolar proteinosis requiring “hybrid” extracorporeal life support, and complicated by acute necrotizing pneumonia

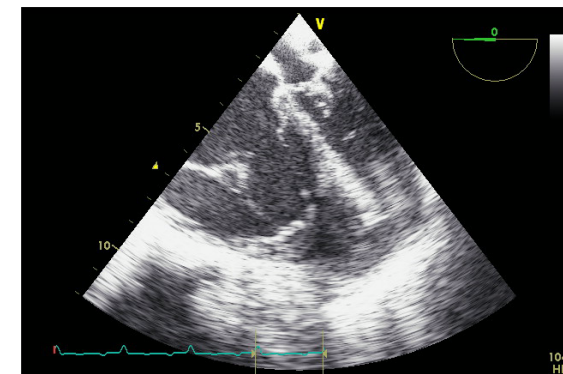
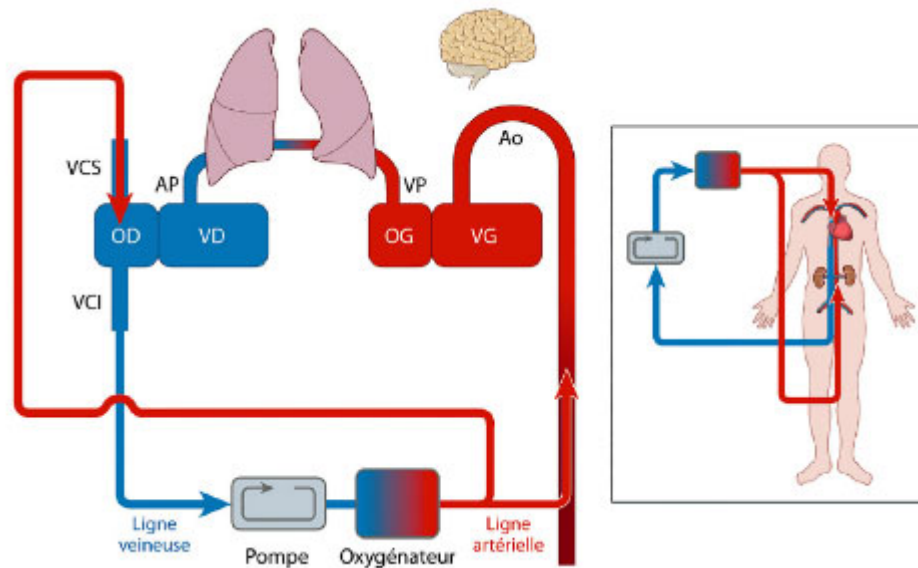

# Precardiac oxygenation

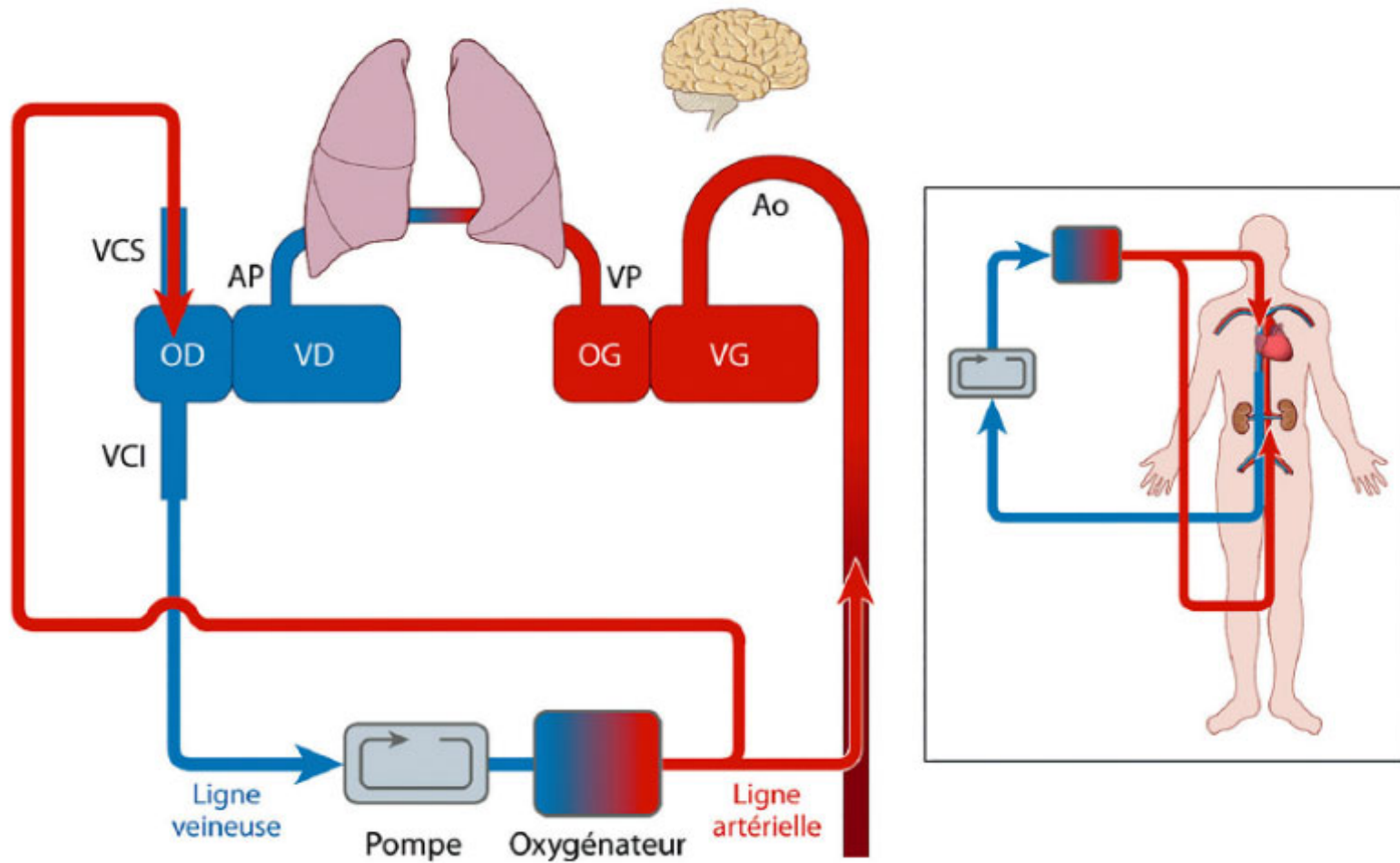

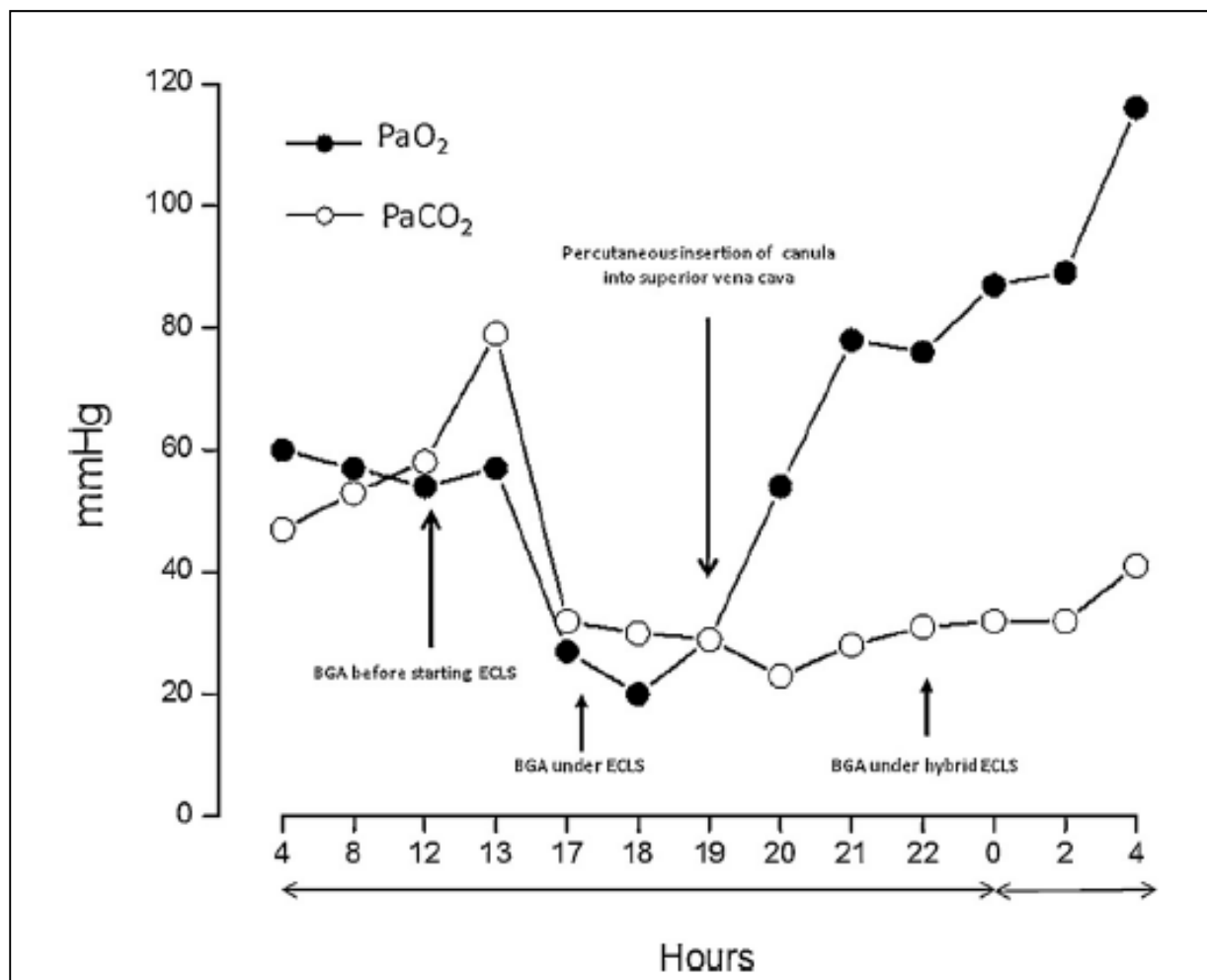

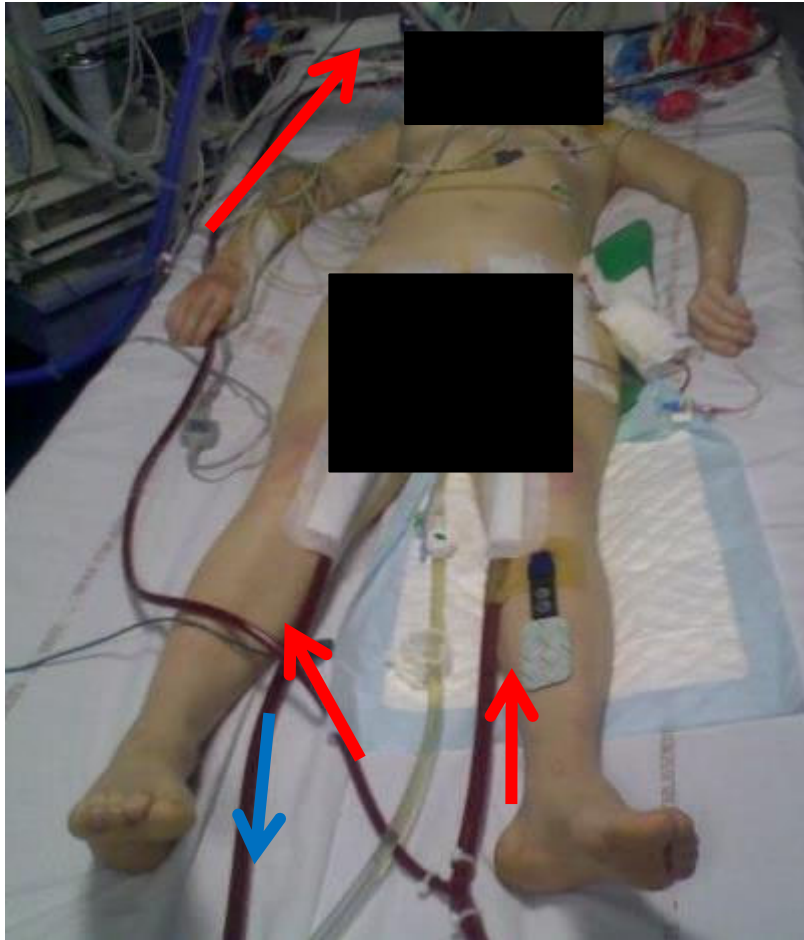

Re-infusion canula 17 Fr



Connection 3/8-1/4  
(arterial return)

# Measurement of re-infusion flow by doppler

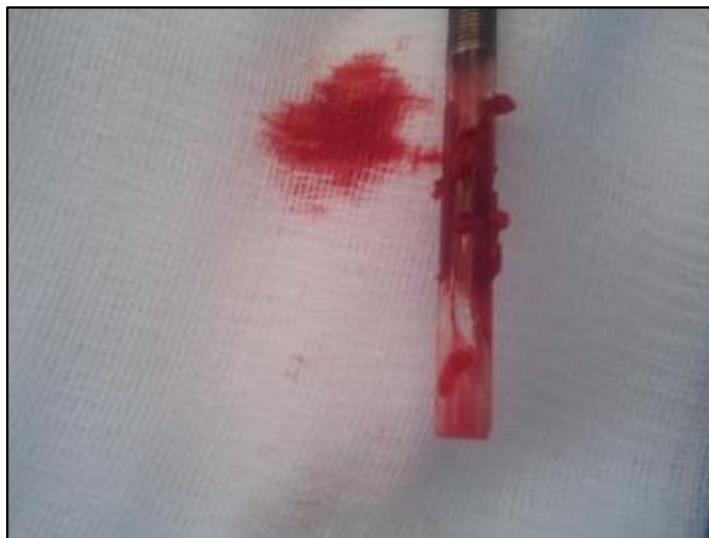

# Mechanical Circulatory Support Devices for Acute Right Ventricular Failure

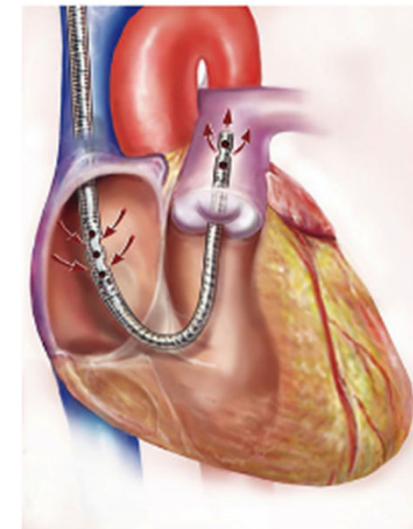
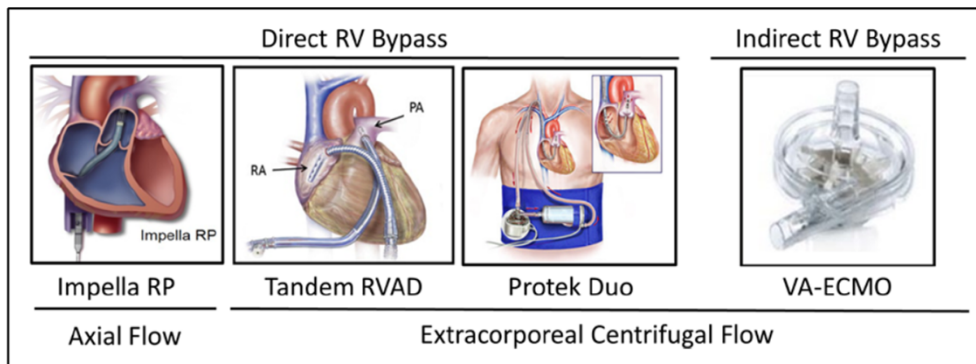

## DEFINITION OF WEANING FROM ECLS

Weaning successful from ECLS is defined as: 1) device removal **and** 2) no further requirement for mechanical support because of recurring CS over the following **7 to 30 days (alive patients)**

# Weaning from ECLS does not mean alive....

In-hospital mortality and successful weaning from venoarterial extracorporeal membrane oxygenation: analysis of 5,263 patients using a national inpatient database in Japan



*Aso S et al. Crit Care 2016; 20:80*

**Table 2** In-hospital death and weaning from VA-ECMO among patients classified by six etiological categories

	All	Total in-hospital death	In-hospital death under VA-ECMO		Transferred to other hospitals with VA-ECMO		Weaning from VA-ECMO		64.4%	
							Discharged after weaning from VA-ECMO		In-hospital death after weaning from VA-ECMO	
All, <i>n</i> (%)	5263	3817	(72.5)	1823 (34.6)	51	(1.0)	1395 (26.5)		1994	(37.9)
Cardiogenic shock, <i>n</i> (%)	4658	3429	(73.6)	1554 (33.4)	44	(0.9)	1185 (25.4)		1875	(40.3)
Pulmonary embolism, <i>n</i> (%)*	353	226	(64.0)	151 (42.8)	7	(2.0)	120 (34.0)		75	(21.2)
Hypothermia, <i>n</i> (%)*	99	65	(65.7)	49 (49.5)	0	(0.0)	34 (34.3)		16	(16.2)
Poisoning, <i>n</i> (%)**	50	31	(62.0)	22 (44.0)	0	(0.0)	19 (38.0)		9	(18.0)
Trauma, <i>n</i> (%)*	103	66	(64.1)	47 (45.6)	0	(0.0)	37 (35.9)		19	(18.4)

\**p* < 0.001 for in-hospital death after weaning from venoarterial extracorporeal membrane oxygenation (VA-ECMO) vs. cardiogenic shock

\*\**p* < 0.05 for in-hospital death after weaning from VA-ECMO vs. cardiogenic shock

# IMPACT OF VA-ECMO ON CARDIAC (LEFT AND RIGHT) LOADING CONDITIONS

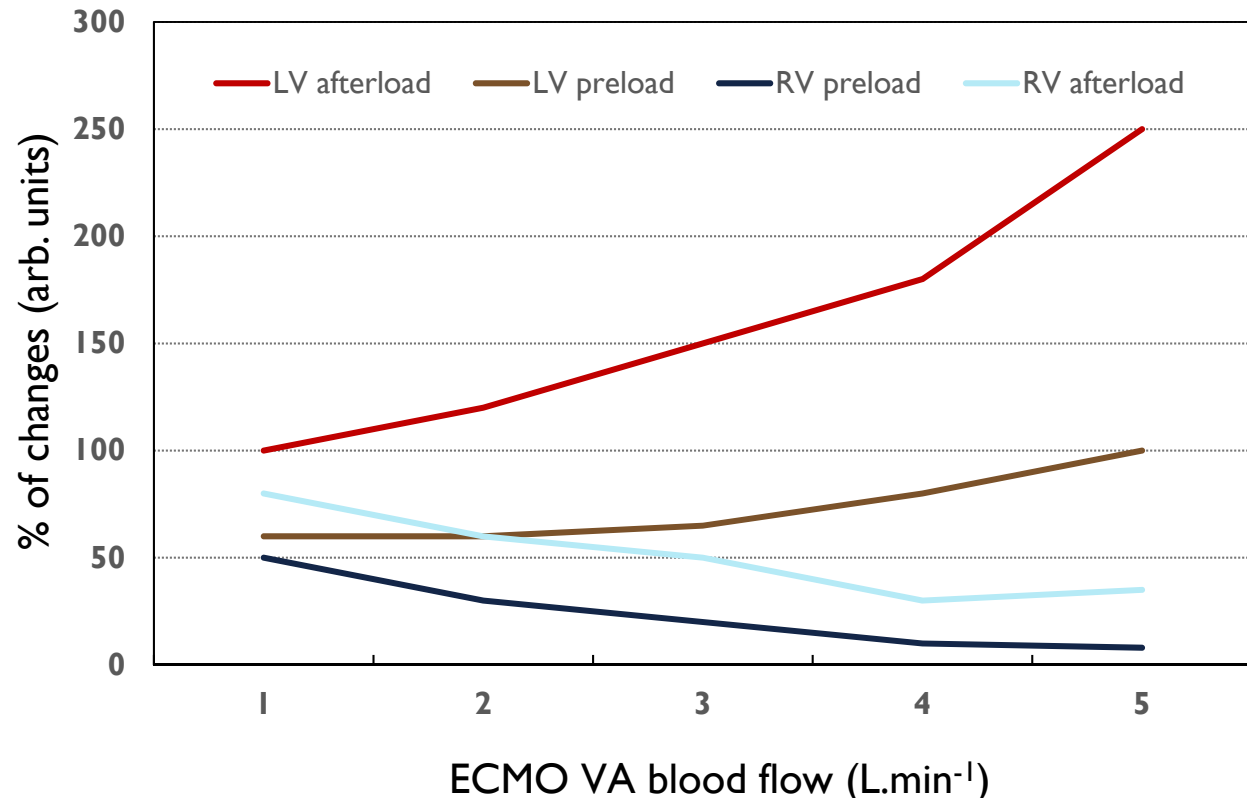
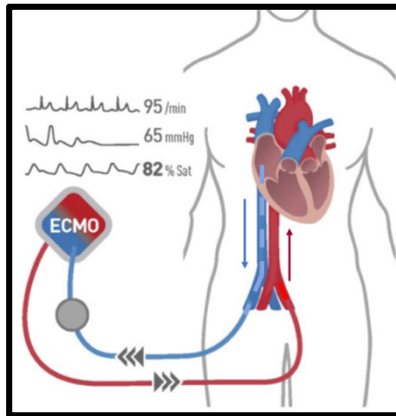

# Weaning procedure from VA-ECMO

Changes in ventricular function parameters (Left **and** Right) in response to ECLS blood flow changes

Assessment of ventricular function (Left **and** right) at the minimal ECLS flow

- Increase in **RV** preload
- Increase in **RV** afterload
- Decrease in **LV** afterload

- △ Weaned patients
- Non weaned patients

LV parameters....

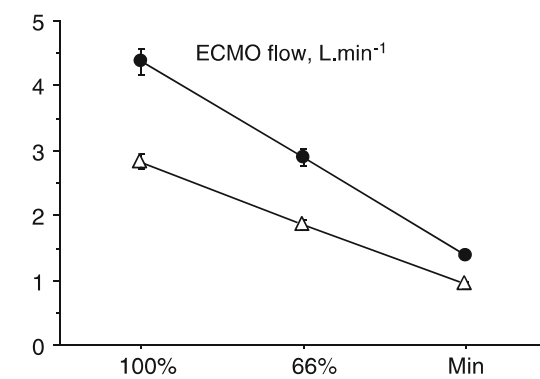
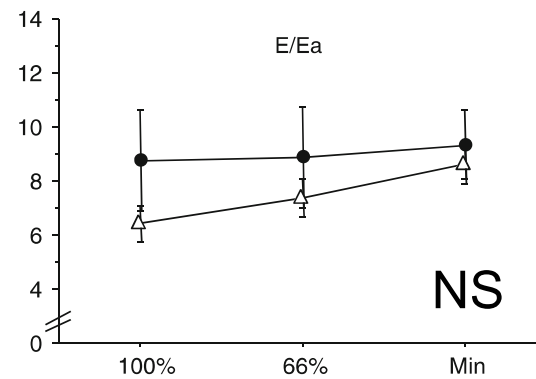
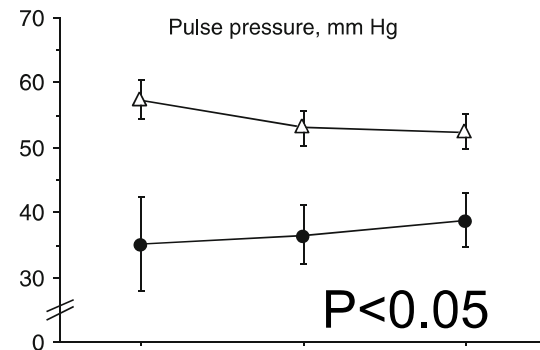
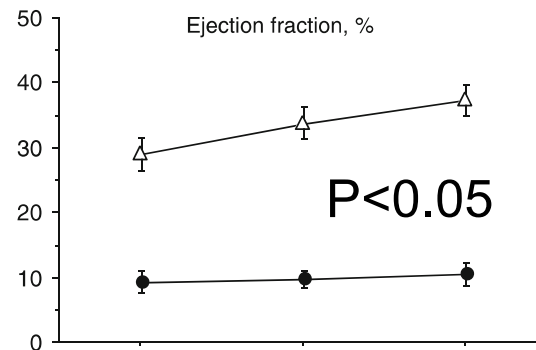
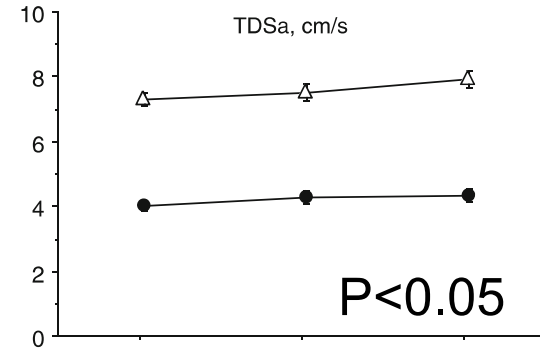
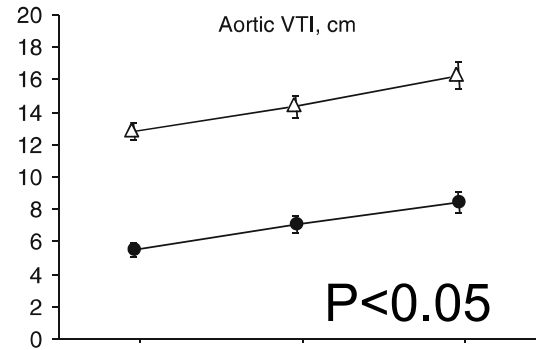

# Weaning test from ECLS

Step 1 : The etiology of cardiac failure must be compatible with myocardial recovery

Step 2 : Hemodynamic stability :

- The patient should have recovered from major metabolic disturbances
- The patient should have recovered a pulsatile arterial waveform for at least 24 hours
- Baseline MAP > 60 mmHg in the absence or with low doses of catecholamine

Step 3 : Pulmonary function should not be severely impaired

*If PaO<sub>2</sub>/FiO<sub>2</sub> <100 mmHg when FiO<sub>2</sub> of the ECMO gas flow is set at 21%, consider bridging the patient from VA- to VV-ECMO*

Step 4 : The patient must tolerate a full weaning trial

*\* Hemodynamic and Doppler-echocardiographic assessment whereas ECMO flow is gradually decreased to 66%, and to 33% of its baseline value and then to a minimum of 1–1.5 L/min*

If steps 1, 2, 3 and 4 are validated and the patient has under minimal ECMO support  
LVEF of ≥ 20–25%, an aortic VTI of ≥ 12 cm and a TDSa ≥ 6 cm/s,

ECMO removal should be considered

**60-75% of patients tolerated successfully the weaning from ECLS**

# Prognostic Implication of RV Coupling to Pulmonary Circulation for Successful Weaning From Extracorporeal Membrane Oxygenation

Kim D et al. J Am Coll Cardiol Imag 2021;14:1523-31

Unicenter study (n=79) between 2016 and 2019

Explore if right ventricular (RV) contractile function and its coupling pulmonary circulation were able to predict successful weaning from ECLS

**At full ECLS blood flow +++ (avoid harmful haemodynamic effects)**

**TABLE 2 Comparisons of Echocardiographic Parameters Between Successful and Failed Weaning Groups**

	Successful Weaning (n = 50)	Failed Weaning (n = 29)	p Value
ECMO flow at time of echocardiography, l/min	3.1 (3.0-3.5)	3.3 (3.0-4.0)	0.304
LV end-diastolic dimension, mm	52 (48-60)	56 (49-65)	0.122
LV end-systolic dimension, mm	42 (37-49)	48 (35-59)	0.232
LV ejection fraction, %	24 (19-35)	23 (15-37)	0.862
Transmitral E velocity, m/s	0.56 (0.44-0.68)	0.61 (0.55-0.83)	0.032
Transmitral A velocity, m/s	0.54 (0.36-0.69)	0.35 (0.39-0.57)	0.165
Lateral mitral S' velocity, cm/s	4.6 (3.3-6.0)	4.6 (3.3-6.0)	0.309
Lateral e' velocity, cm/s	4.4 (3.9-7.9)	4.4 (3.6-6.0)	0.617
E/Lateral e'	9.6 (6.6-18.3)	14.4 (10.8-18.3)	0.005
LVOT velocity-time integral, cm	8.5 (5.9-12.5)	7.4 (4.5-12.2)	0.338
RV end-diastole area, cm <sup>2</sup>	13.1 (10.6-16.5)	16.2 (11.9-24.8)	0.073
RV end-systole area, cm <sup>2</sup>	8.8 (7.1-11.6)	9.5 (7.8-18.1)	0.104
Indexed RV end-diastole area, cm <sup>2</sup>	7.65 (6.09-9.42)	9.03 (7.07-12.9)	0.054
Indexed RV end-systole area, cm <sup>2</sup>	5.17 (4.20-6.12)	6.46 (4.50-8.85)	0.122
TAPSE, mm	12.8 (9.1-15.0)	11.3 (7.1-13.0)	0.243
Tricuspid annular S' velocity, m/s	8.7 (6.0-10.7)	6.4 (5.1-8.3)	0.064
RV FAC, %	33.1 (24.2-38.6)	28.5 (19.5-38.7)	0.378
[RV FWLS], %	14.1 (8.7-19.8)	10.4 (7.9-14.6)	0.054
RVSP, mm Hg	27 (19-36)	33 (24-42)	0.040
Tricuspid annular S'/RVSP	0.32 (0.18-0.44)	0.21 (0.14-0.29)	0.004
RV FAC/RVSP	1.04 (0.73-1.59)	0.87 (0.53-1.31)	0.134
TAPSE/RVSP	0.45(0.29-0.68)	0.31 (0.25-0.40)	0.019
[RV FWLS]/RVSP	0.49 (0.32-0.82)	0.31 (0.22-0.48)	0.007

## At full ECLS blood flow....!

**TABLE 3 Predictors for Successful ECMO Weaning**

	Univariable Analysis	
	OR (95% CI)	p Value
Age	1.02 (0.98-1.06)	0.286
Idiopathic-dilated cardiomyopathy	0.15 (0.40-0.64)	0.004
Continuous renal replacement therapy	0.28 (0.11-0.75)	0.011
Extracorporeal CPR	2.81 (1.05-7.55)	0.040
LV venting	0.07 (0.02-0.19)	<0.001
Early venting (<12 h)	0.17 (0.04-0.70)	0.014
LV ejection fraction >20%	1.25 (0.46-3.42)	0.661
LVOT velocity-time integral ≥10 cm	1.25 (0.46-3.42)	0.664
Mitral annular S' ≥6 cm/s	2.37 (0.82-6.85)	0.113
FAC/RVSP ≥0.94	2.52 (0.98-6.52)	0.056
Tricuspid annular S'/RVSP >0.33	8.01 (2.15-29.92)	0.002
TAPSE/RVSP >0.45	4.09 (1.34-12.43)	0.013
[RV FWLS/RVSP] >0.45	4.21 (1.53-11.41)	0.005

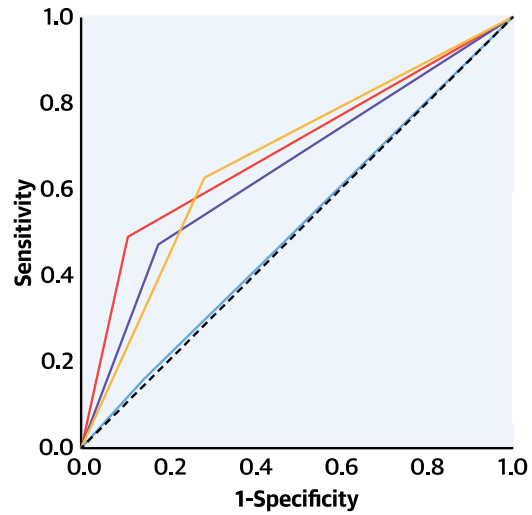

Conventional Echo Criteria: AUC = 0.507, 95% CI:0.373 - 0.641, p = 0.918  
 Tricuspid Annular S'/RVSP >0.33: AUC = 0.692, 95% CI: 0.574 - 0.809, p = 0.005  
 TAPSE/RVSP >0.45: AUC = 0.646, 95% CI: 0.522 - 0.770, p = 0.033  
 [RV FWLS]/RVSP >0.45: AUC = 0.671, 95% CI: 0.546 - 0.796, p = 0.012

— Conventional Echo Criteria — Tricuspid Annular S'/RVSP >0.33  
 — TAPSE/RVSP >0.45 — [RV FWLS]/RVSP >0.45

— Conventional echocardiographic criteria at minimal flow  
 ( AUC=0.580, 95% CI:0.442-0.718, p=0.257)  
 — Tricuspid annular S'/RVSP> 0.33 at full flow  
 ( AUC=0.677, 95%CI: 0.549-0.804, p=0.016)  
 — Tricuspid annular S'/RVSP> 0.33 at full flow  
 +Conventional echocardiographic criteria at minimal flow  
 (AUC=0.703. 95% CI: 0.579- 0.828, p=0.005)

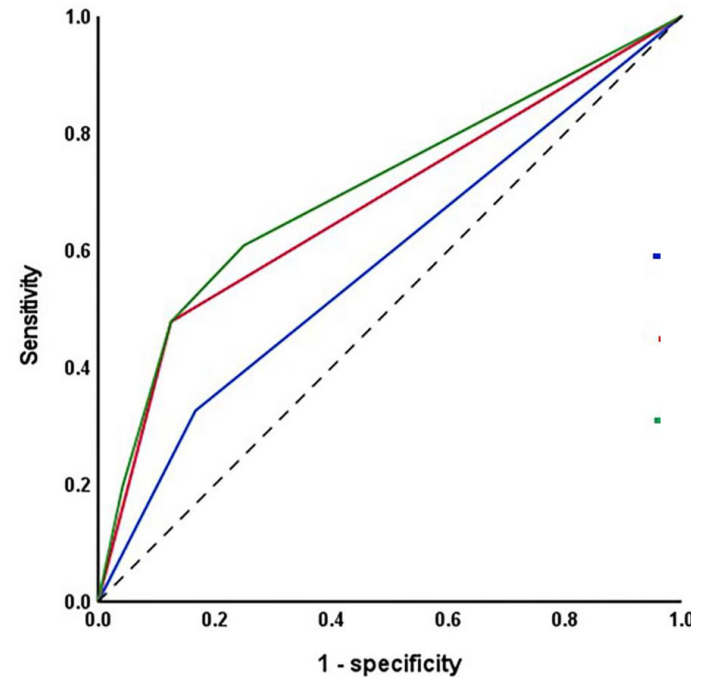

Step 1: The **etiology** of cardiac failure must be compatible with myocardial recovery

Step 2: **Hemodynamic stability:**

- The patient should have recovered a pulsatile arterial waveform for at least 24 hours
- Baseline MAP >60 mmHg in the absence or with low doses catecholamine and/or pulsed pressure >
- The patient should have recovered from major metabolic disturbances

Step 3: **Pulmonary function** should not be severely impaired

*If PaO<sub>2</sub>/FiO<sub>2</sub> <100 mmHg when FiO<sub>2</sub> of the ECMO gas flow is set at 21%, consider bridging the patient from VA- to VV-ECMO*

Step 4: The patient **must tolerate a full weaning trial**

\* Hemodynamic and echocardiographic assessment whereas ECMO flow is gradually decreased to 66%, and to 33% of its baseline value and then to a minimum of 1–1.5 L/min

If steps 1, 2, 3 and 4 are validated and the patient has under minimal ECMO support:

- LVFF of > 20–25%, an aortic VTI of >12 cm and a TDSa ≥6 cm/s

- 3D-RV ejection fraction (if feasible) >24.6%

ECMO removal should be considered

Tricuspid annular S'/RVSP >0.33

TAPSE/RVSP >0.45

[RV FWLS/RVSP] >0.45

**at full ECLS blood flow**

# Effects of levosimendan on weaning and survival in adult cardiogenic shock patients with veno-arterial extracorporeal membrane oxygenation: systematic review and meta-analysis

Analysis of risk of successful weaning from VA ECMO in patients treated with levosimendan

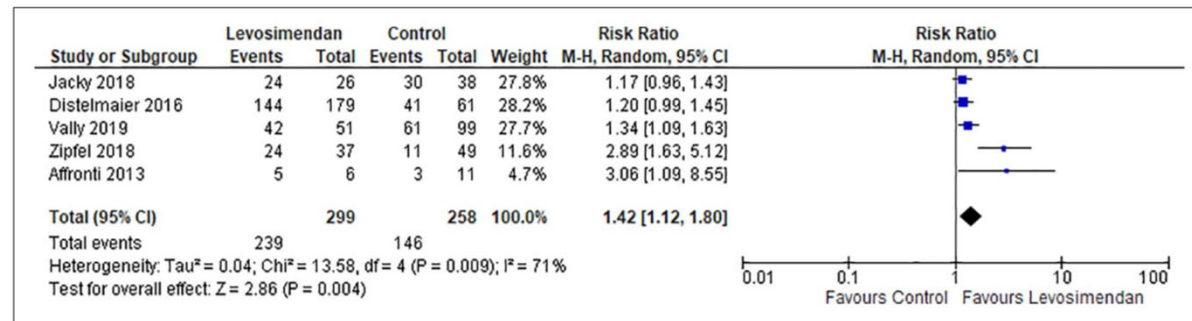

Analysis of risk of all-cause mortality in VA ECMO patients treated with levosimendan

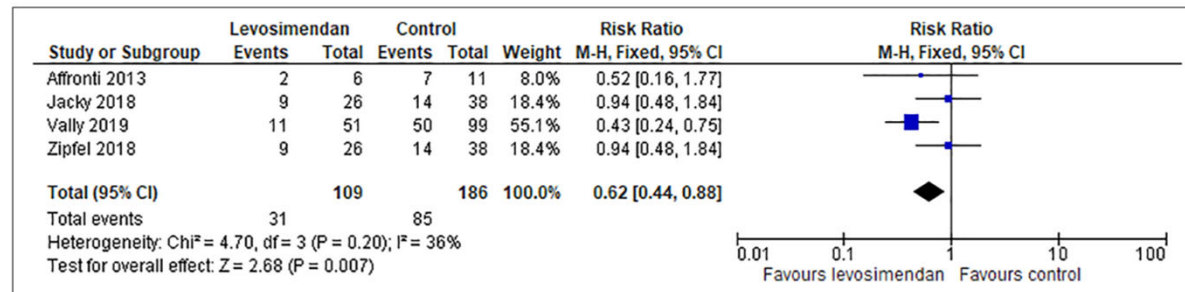

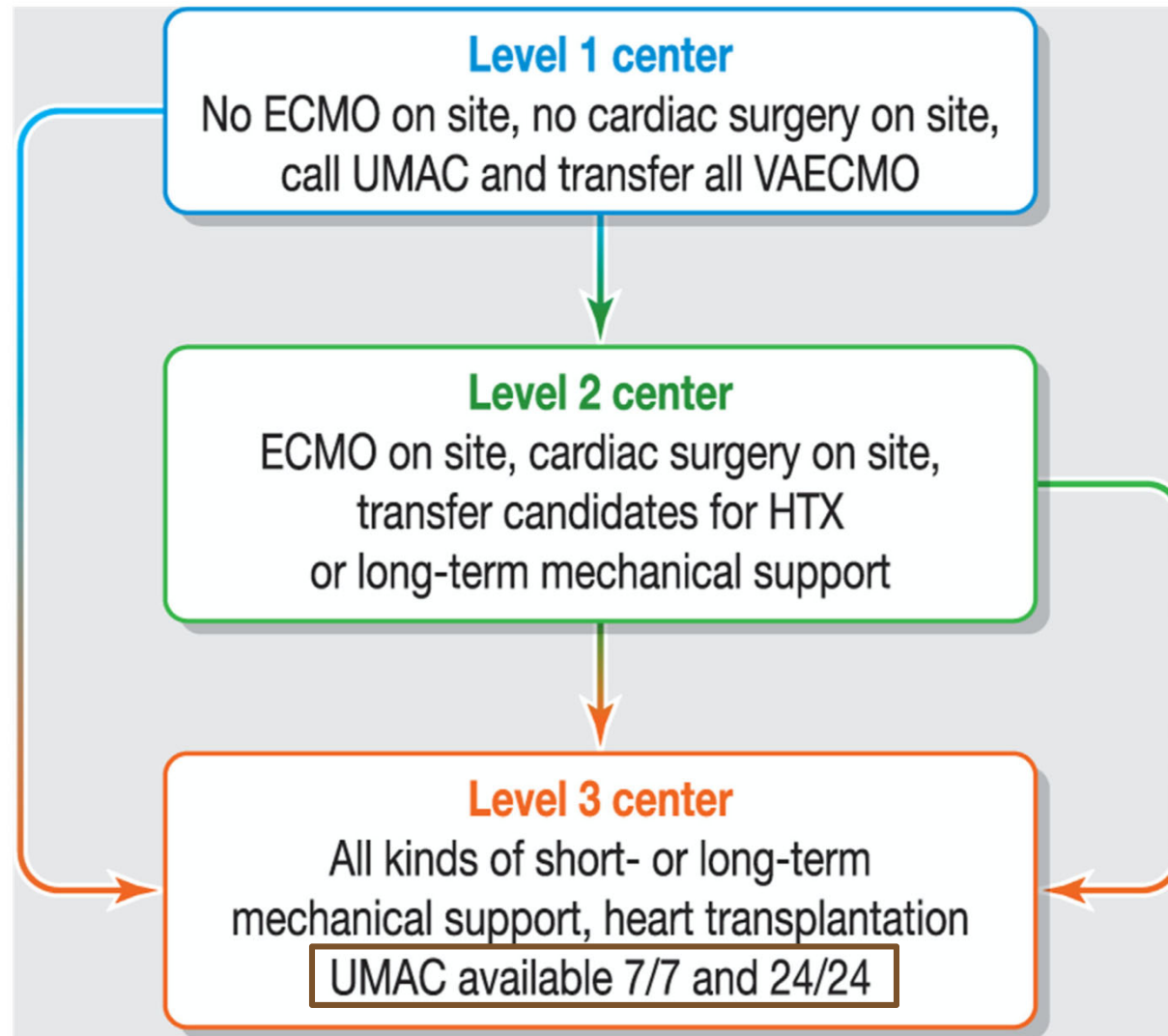



P. Forrest  
J. Ratchford  
B. Burns  
R. Herkes  
A. Jackson  
B. Plunkett  
P. Torzillo  
P. Nair  
E. Granger  
M. Wilson  
R. Pye

## Retrieval of critically ill adults using extracorporeal membrane oxygenation: an Australian experience



800 000 km<sup>2</sup> (X 1,5 F)  
6 100 000 h





# DEPARTMENT OF ANAESTHESIA AND CRITICAL CARE OF HAUT-LEVEQUE HOSPITAL: REFERRAL ECMO CENTER

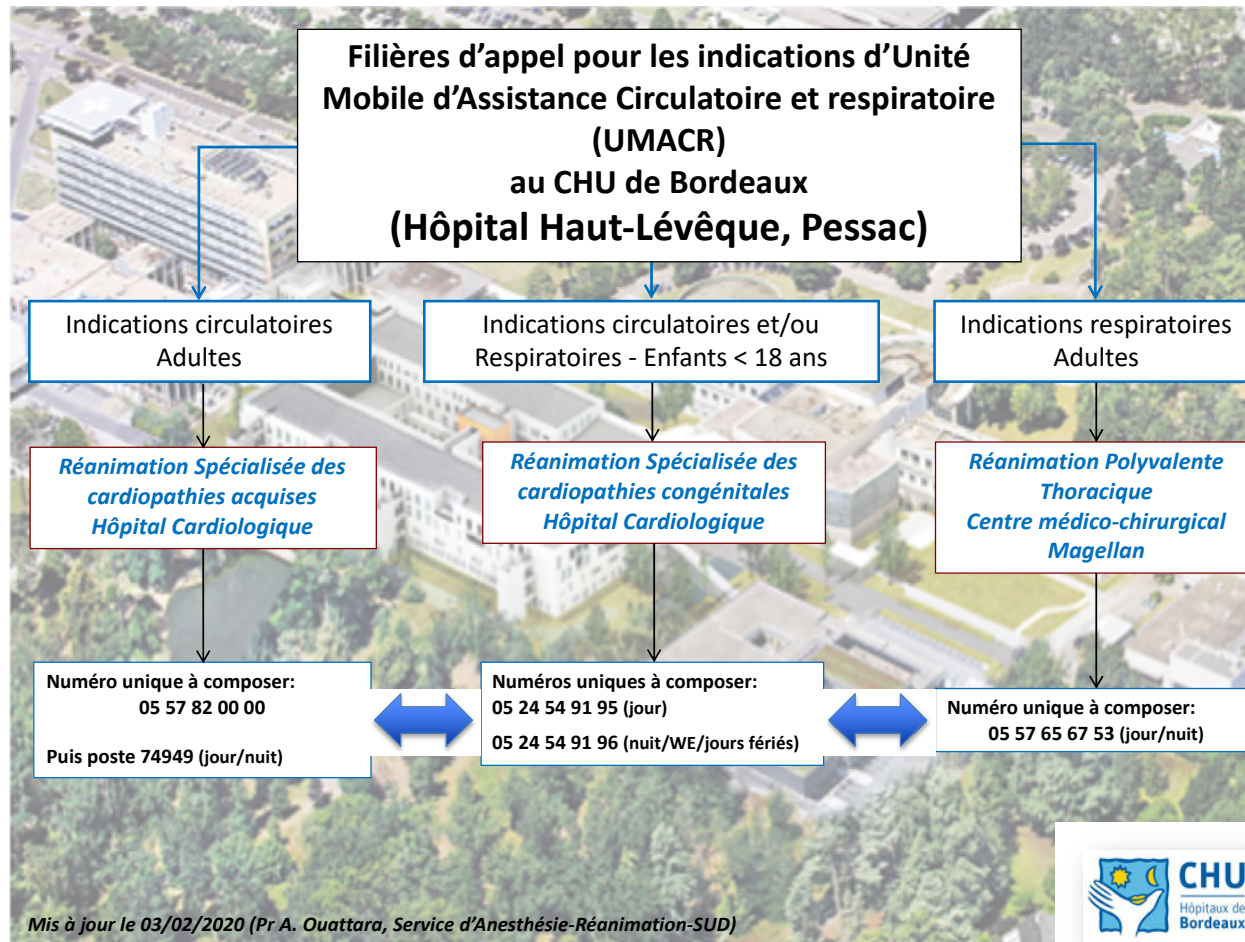

# Mobile circulatory support unit



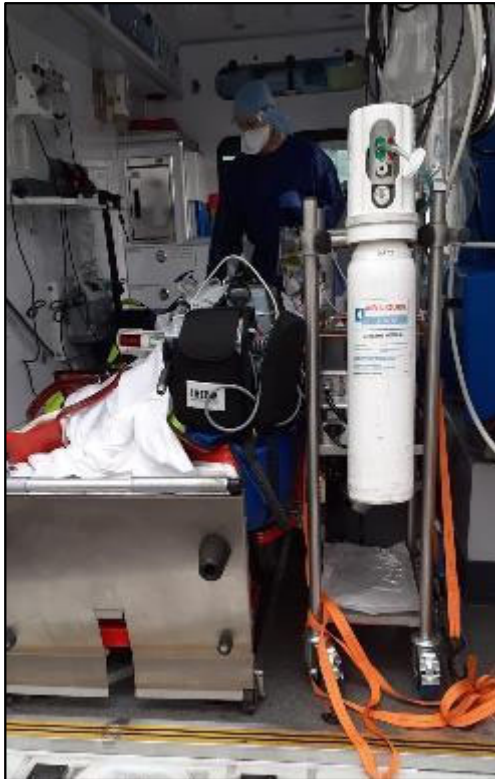

ROTAFLOW and  
specific (smaller)  
TROLLEY  
(2020)



# Miniaturisation...



CardioHelp (Maquet)



HLS Module Advanced 7.0:

- Oxygénateur à membrane diffusion
- Pompe centrifuge innovante intégrée
- Marquage CE pour **30 J et le transport**
- Traitement de surface BIOLINE

## Global activity (n=126)

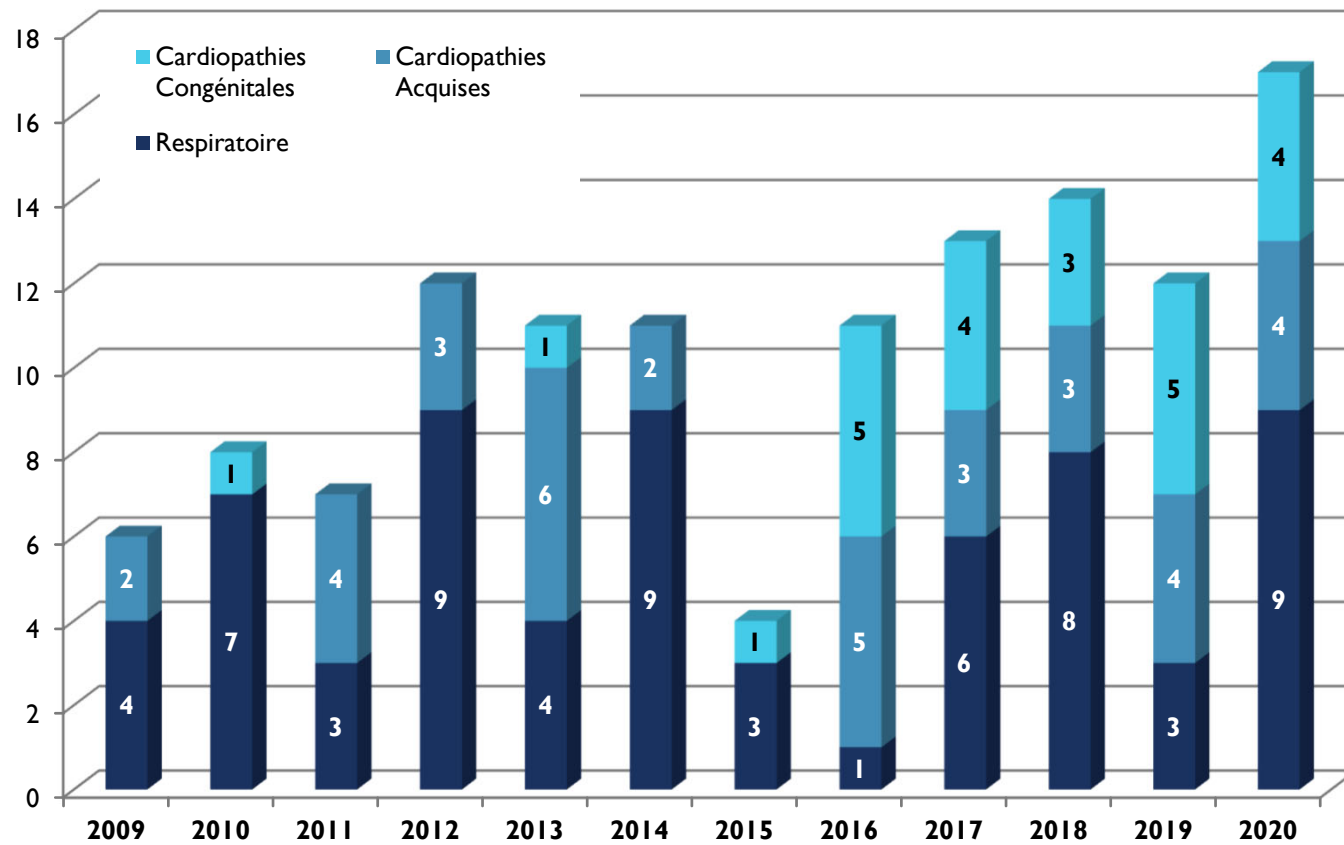

*Data from 126 patients managed by our Mobile assistance unit between 2009 and 2020*

Age, year	33 [16-53]
Male, %	84 (67%)
Duration of ECMO, days	10 [2-23]
IGS II	52 [38-68]
In-hospital Mortality, %	46 (36.2%)
Distance, km	10 [10-146]

## *SHORT-TERM MECHANICAL CIRCULATORY SUPPORT...*

- ✓ Rescue and temporary strategy to restore end-organ perfusion
- ✓ Intrinsic morbidity and even mortality (ischemia, bleeding,...)
- ✓ Impact on intra-cardiac haemodynamic (failing myocardium)
- ✓ Potentially harmful for myocardial recovery (ventricular remodeling)
- ✓ Multidisciplinary cardiogenic shock team approach
- ✓ Multimodal and evolutive strategy
- ✓ Further research still required to confirm and quantify outcome improvement
- ✓ And identify the best strategy regarding the severity of CS

# **INSERM, UMR 1034 Biology of cardiovascular diseases** *Systemic and cardiac haemodynamics in acute heart failure*

## **Program leaders**

Professor Alexandre OUATTARA MD PhD (Anesthesia and Critical care)

Professor Thierry COUFFINHAL MD PhD (Cardiology)

## **Seniors**

Associate Professor Julien IMBAULT MD

Associate Professor Mario RIENZO MD PhD

## **PhD Students**

Antoine BEURTON MD MSc

## **MSc Students**

FX HERION MD

Claire ODDOS MD

Elora BORDIER MD

Simon VEYRET MD



